

Table of Contents

Introduction

This Application Guide is to assist you in understanding the principles of electric thermal systems and components as they apply to various heating tasks. Its purpose is to give you theory, general calculations and engineering data along with examples for solving heating problems. This Application Guide is not a how-to manual or a substitute for specific information related to complex and/or critical applications. Watlow engineers are available to provide you detailed information on engineering approaches not included in this guide. When designing any thermal system, caution must always be exercised to comply with safety requirements, local and/or national electrical codes, agency standards, considerations for use in toxic or explosive environments and sound engineering practices. Integrity and suitability of any thermal system design/specification is ultimately the responsibility of those selecting and approving system components.

This Application Guide is organized into sections dealing with the basic facets of an electric thermal system: the electric heaters, temperature sensors and temperature and power controllers. Information about wiring practices along with reference data and examples are also provided.

As always, Watlow Electric Manufacturing Company stands ready to provide you advice or engineering expertise to design and produce components to meet your electric heating requirements.

Customer Assistance

Manufacturing Facilities 3
Sales Offices 4

Electric Heaters



Product Overview 7
Power Calculations 15
Power Evaluation 19
Review of Heater Application Factors 20
Select Heater 22
Reference Data 24
Heat Loss Factors and Graphs .. 26
Quick Estimates of Wattage Requirements 30

Temperature Sensors



Product Overview 34
Contact Temperature Sensors Types and Comparisons 36
Thermocouples 37

Resistance Temperature Detectors (RTDs) 49
Thermistors 52
Non-Contact Temperature Sensor Basics 54
Defining an Application and Determining a Solution 60
Reference Data 61
Thermocouple and Resistance Wire RTD Initial Calibration Tolerances 61
RTD Resistance vs. Temperature Tables (Standard Thermistors) .. 63
RTD Resistance vs. Temperature Tables (DIN Platinum RTDs) 70

Temperature Controllers



Product Overview 74
Thermal Control Principles 81
Control Output Types 88
Control Output Comparison 90
Limit Control Protection for Temperature Process 93
Agency Recognition for Controllers 94
Control System Tuning 94
Typical Thermal Control System Chart Recordings 97
Controller Overview 99
Data Communications 100

Table of Contents

Power Controllers



| | |
|---|------------|
| <i>Product Overview</i> | 101 |
| <i>Five Basic Types</i> | 102 |
| <i>Theory of SCR Power Controllers</i> .. | 108 |
| <i>Methods of Firing SCRs</i> | 109 |
| <i>Enclosure Guidelines</i> | 112 |
| <i>Heater Life and Selection of Power Handling Device</i> | 113 |
| <i>SCR Protective Devices</i> | 114 |

Wiring Practices

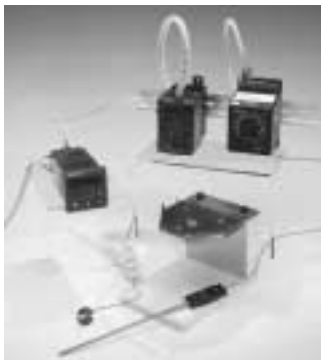

| | |
|---|------------|
| <i>Electrical Noise</i> | 116 |
| <i>Helpful Wiring Guidelines</i> | 118 |
| <i>Input Power Wiring</i> | 120 |
| <i>Output Wiring</i> | 122 |
| <i>SCR Wiring – Tips and Special Considerations</i> | 124 |

Reference Data

| | |
|---|------------|
| <i>Celsius to Fahrenheit / Fahrenheit to Celsius</i> | 127 |
| <i>Ratings of Listed Heater Voltages Operated on Other Voltages</i> | 129 |
| <i>Conversion Factors</i> | 130 |
| <i>Commonly Used Geometric Areas and Volume</i> | 133 |
| <i>Physical Properties of Solids, Liquids and Gases</i> | 134 |
| <i>Properties of Non-Metallic Solids</i> | 134 |
| <i>Properties of Metals</i> | 137 |
| <i>Properties of Metals in Liquid State</i> | 139 |
| <i>Properties of Liquids</i> | 140 |
| <i>Properties of Gases</i> | 143 |
| <i>Properties of Air</i> | 143 |
| <i>Corrosion Guide</i> | 144 |
| <i>Examples of Applications</i> | 156 |
| <i>Cabinet Freeze Protection</i> | 156 |
| <i>Heating a Steel Mold</i> | 158 |
| <i>Melting of Aluminum</i> | 164 |
| <i>Heating Liquid in a Tank</i> | 174 |
| <i>Heating a Flowing Liquid</i> | 178 |
| <i>Air Duct Heater</i> | 182 |
| <i>Drying a Moving Web of Cloth</i> .. | 186 |

Glossary

| | |
|--|------------|
| <i>Definitions of Commonly Used Terms Used in Heating, Sensing and Controlling</i> | 188 |
|--|------------|

Watlow Products and Technical Support Delivered Worldwide

Watlow's worldwide sales and distributor network

If you don't find what you need in this Application Guide, call the Watlow office nearest you listed on the following. One phone call gives you instant access to expert technical advice, application assistance and after-the-sale service. In addition, more than 150 authorized distributors are located in the U.S. and 42 other countries.

For up-to-date information on Watlow's new products or services, see Watlow's home page on the Internet at <http://www.watlow.com>.

Customer Assistance

Watlow Manufacturing Facilities

United States Manufacturing Facilities

Anaheim, California

Watlow AOV, Inc.

Manufactures:

- Silicone Rubber Heaters
- 1400 North Kellogg Drive, Suite A
Anaheim, CA 92807
Phone: 714-779-2252
FAX: 714-777-9626

Batavia, Illinois

Watlow Batavia

Manufactures:

- Cast-In Heaters
- 1310 Kingsland Drive
Batavia, IL 60510
Phone: 630-879-2696
FAX #1: 630-879-1101
FAX #2: 630-482-2042

Columbia, Missouri

Watlow Columbia/Ceramic Fiber

Manufactures:

- Ceramic Fiber Heaters
- 2407 Big Bear Court
Columbia, MO 65202
Phone: 573-443-8817
FAX: 573-443-8818

Watlow Columbia/Flexible

Manufactures:

- Flexible Heaters
- 2101 Pennsylvania Drive
Columbia, MO 65202
Phone: 573-474-9402
FAX: 573-474-5859

Fenton, Missouri

Single Iteration

A Consulting Services Division of Watlow

- 909 Horan Drive
Fenton, MO 63026
Phone: 866-449-6846
FAX: 636-349-5352

Hannibal, Missouri

Watlow Hannibal

Manufactures:

- Circulation Heaters
- Duct Heaters
- Immersion Heaters
- Multicell Heaters
- Tubular Heaters
- Thick Film Heaters

#6 Industrial Loop Road
P.O. Box 975
Hannibal, MO 63401

Phone: 573-221-2816
FAX: Tubular/Process/Multicell
573-221-3723
FAX: Thick Film
573-221-7578

Richmond, Illinois

Watlow Richmond

Manufactures:

- RTDs, Thermocouples, Thermistors
- Thermocouple Wire and Cable
- Temperature Measurement Devices

5710 Kenosha Street, P.O. Box 500
Richmond, IL 60071

Phone: 815-678-2211
FAX: 815-678-3961

St. Louis, Missouri

World Headquarters and Watlow St. Louis

Manufactures:

- Band Heaters
- Cable Heaters
- FIREROD® Heaters
- Radiant Heaters
- Special Heaters
- Strip Heaters

12001 Lackland Road
St. Louis, MO 63146

Phone: 314-878-4600
FAX: 314-878-6814

Watsonville, California

Watlow Anafaze

Manufactures:

- Multi-loop Controls
- High Level Software

Phone: 507-454-5300
FAX: 507-452-4507

Winona, Minnesota - Controls

Watlow Winona, Inc.

Manufactures:

- Custom Electronic Controllers
- Power Controls
- Safety and Limit Controls
- Single Loop Controls

1241 Bundy Boulevard, P.O. Box 5580
Winona, MN 55987-5580

Phone: 507-454-5300
FAX: 507-452-4507

Winona, Minnesota - Polymer

Watlow Polymer Technologies, Inc.

Manufactures:

- Polymer Heaters
- 1265 East Sanborn Street
Winona, MN 55987

Phone: 507-457-9797
FAX: 507-457-9736

Wright City, Missouri

4/1/02 (formerly Troy, MO)

Watlow Process Systems

Manufactures:

- Process Heating Systems

#10 Cooperative Way
Wright City, Missouri 63390

Phone: 636-745-7575
FAX: 636-745-0537

Asian Manufacturing Facilities

Singapore

Watlow Singapore Pte. Ltd.

Manufactures:

- FIREROD® Heaters
- Thermocouples

55 Ayer Rajah Crescent, #03-23
Singapore 139949

Phone: 65-67780323
FAX: 65-67739488

European Manufacturing Facilities

France

Watlow France, S.A.R.L. (Sales Office)

Immeuble Ampère
Z.I. Rue Ampère
95307 Cergy Pontoise Cedex, France

Phone: 33-1-3073-2425
FAX: 33-1-3073-2875

Customer Assistance

Watlow Manufacturing Facilities

European Manufacturing Facilities (con't.)

Germany

Watlow GmbH

Manufactures:

- Cable Heaters
- Cartridge Heaters (FIREROD, EB Cartridge and Metric FIREROD)
- Silicone Rubber Heaters
- K-RING® Heaters
- Pump Line Heaters
- Electronic Assemblies

Lauchwasenstr. 1

Postfach 1165

D 76709 Kronau, Germany

Phone: 49-7253-94-00-0

FAX: 49-7253-94-00-44

Italy

Watlow Italy, S.r.l.

Manufactures:

- Thermocouples

Via Meucci 14

20094 Corsico - MI, Italy

Phone: 39-02-4588841

FAX: 39-02-45869954

United Kingdom

Watlow Limited

Manufactures:

- Band Heaters
- Cartridge Heaters
- FIREROD Heaters
- Flexible Heaters
- Thermocouples

Robey Close

Linby Industrial Estate

Linby, Nottingham, England NG15 8AA

Phone: 44-0-115-964-0777

FAX: 44-0-115-964-0071

Latin American Manufacturing Facilities

Mexico

Watlow de Mexico, S.A. de C.V.

Manufactures:

- FIREROD Heaters (Cartridge and Metric)
- Ceramic Knuckle Heaters
- THINBAND® Heaters
- HV Band Heaters
- Silicone Rubber Heaters
- Tubular Heaters
- Cable Heaters

Cto El Marqués Nte 44

Parque Industrial El Marqués

Queretaro C.P. 76246

Queretaro, Mexico

Phone: 52-442-256-22-00

Fax: 52-442-217-64-03

Sales Support

United States Sales Offices

Atlanta

1320 Highland Lake Drive
Lawrenceville, GA 30045-8225

Phone: 770-972-4948

Fax: 770-972-5138

Austin

12343 Hymeadow, Suite 2L
Austin, TX 78750-1830

Phone: 512-249-1900

Fax: 512-249-0082

Birmingham

308 Honeysuckle Lane
Chelsea, AL 35043-9669

Phone: 205-678-2358

Fax: 205-678-2567

Charlotte

10915 Tara Oaks Drive
Charlotte, NC 28227-5493

Phone: 704-573-8446

Fax: 866-422-5998

Chicago

1320 Chase Street, Suite 2
Algonquin, IL 60102-9668

Phone: 847-458-1500

Fax: 847-458-1515

Cincinnati

4700 Duke Drive, Suite 125
Mason, OH 45040-9163

Phone: 513-398-5500

Fax: 513-398-7575

Cleveland

28 West Aurora
Northfield, OH 44067-2063

Phone: 330-467-1423

Fax: 330-467-1659

Dallas

PO Box 704011
Dallas, TX 75370-4011

Phone: 972-620-6030

Fax: 972-620-8680

Denver

5945 West Sumac Avenue
Littleton, CO 80123-0886

Phone: 303-798-7778

Fax: 303-798-7775

Detroit

155 Romeo Road, Suite 600
Rochester, MI 48307

Phone: 248-651-0500

Fax: 248-651-6164

Houston

3403 Chapel Square Drive
Spring, TX 77388

Phone: 281-440-3074

Fax: 281-440-6873

Indianapolis

160 W. Carmel Drive, Suite 204
Carmel, IN 46032-4745

Phone: 317-575-8932

Fax: 317-575-9478

Customer Assistance

Sales Support

Kansas City

P.O. Box 15539
Lenexa, KS 66285-5539
Phone: 913-897-3973
Fax: 913-897-4085

Los Angeles

1914 West Oranewood Avenue
Suite 101
Orange, CA 92868-2005
Phone: 714-935-2999
Fax: 714-935-2990

Maryland/Virginia

85 Old Dublin Pike
Doylestown, PA 18901-2468
Phone: 215-345-8130
Fax: 215-345-0123

Milwaukee/Appleton

400 South Linwood Avenue, Suite 13
Appleton, WI 54914-4970
Phone: 920-993-2161
Fax: 920-993-2162

Minneapolis

14551 Judicial Road
Suite 127
Burnsville, MN 55306
Phone: 952-892-9222
Fax: 952-892-9223

Nashville

212 Hidden Lake Road
Hendersonville, TN 37075-5502
Phone: 615-264-6148
Fax: 615-264-5654

New England

4 John Tyler Street, Suite E
Merrimack, NH 03054-4800
Phone: 603-882-1330
Fax: 603-882-1524

New York/Upstate

6032 Old Beattie Road
Lockport, NY 14094-7943
Phone: 716-438-0454
Fax: 716-438-0082

Orlando

5514 Meadow Pine Ct.
Orlando, FL 32819
Phone: 407-351-0737
Fax: 407-351-6563

Philadelphia

85 Old Dublin Pike
Doylestown, PA 18901-2468
Phone: 215-345-8130
Fax: 215-345-0123

Phoenix

14830 North 10th Street
Phoenix, AZ 85022-3751
Phone: 602-298-6960
Fax: 888-579-5222

Pittsburgh

1241 West North Avenue
Pittsburgh, PA 15233-1935
Phone: 412-322-5004
Fax: 412-322-1322

Portland

1306 Northeast 149th Place
Vancouver, WA 98684
Phone: 360-254-1009
Fax: 360-254-2912

Sacramento

1698 River Oaks Circle
Fairfield, CA 94533-7797
Phone: 707-425-1155
Fax: 707-425-4455

Saint Louis

12001 Lackland Road
St. Louis, MO 63146-4039
Phone: 636-441-5077
Fax: 636-447-8770

San Francisco

780 Montague Expressway, Suite 308
San Jose, CA 95131
Phone: 408-434-1894
Fax: 408-435-5409

Seattle

1420 NW Gilman Blvd., Suite 2571
Issaquah, WA 98027
Phone: 425-222-4090
Fax: 425-222-5162

Shreveport

149-1/2 Ockley Drive
Shreveport, LA 71105
Phone: 318-864-2864
Fax: 318-864-2864

Tampa/St. Petersburg

831 Huntington Court
Winter Park, FL 32789-4722
Phone: 407-647-9052
Fax: 407-647-5466

Tulsa

4444 East 66th Street, Suite 101
Tulsa, OK 74136-4205
Phone: 918-496-2826
Fax: 918-494-8901

Asian Sales Offices

Australia

Watlow Australia Pty. Ltd.

23 Gladstone Park Drive
Tullamarine, VIC 3043
Australia
Phone: 61 (39) 335-6449
FAX: 61 (39) 330-3566
Sales Territory: Australia, New Zealand

China

Watlow China

Rm 1903, Chang De Building No. 478-5
Chang Shou Road, Shanghai, China
Tel: +(86) 21 62772138
Fax: +(86) 21 62278559
Sales Territory: China

Customer Assistance

Japan

Watlow Japan Ltd.

Azabu Embassy Heights 106
1-11-12 Akasaka
Minato-Ku, Tokyo, Japan 107-0052
Phone: 011-81-3-5403-4688
FAX: 011-81-3-5575-3373
Sales Territory: Japan

Korea

Watlow Korea Co., Ltd.

3rd Fl., Taehong Bldg.
20-6 Yangjae-dong, Seocho-gu
Seoul, Korea 137-130
Phone: 82 (2) 575-9804
FAX: 82 (2) 575-9831
Sales Territory: Korea

Malaysia

Watlow Malaysia Sdn Bhd

38B Jalan Tun Dr Awang
11900 Bayan Lepas, Penang
Malaysia
Phone: 60 (4) 641-5977
FAX: 60 (4) 641-5979
Sales Territory: Malaysia

Singapore

Watlow Singapore Pte. Ltd.

55 Ayer Rajah Crescent, #03-23
Singapore 139949
Phone: + (65) 67739488
FAX: + (65) 67780323
Sales Territory: Singapore, South East
Asia, Hong Kong, India
Sales Support

Taiwan

Watlow Taiwan

10F-1 No. 189
Chi-Shen 2nd Road
Kaohsiung, Taiwan, 801
Phone: 886-7-288-5168
FAX: 886-7-288-5568
Sales Territory: Taiwan

Canadian Sales Offices

Ontario

Watlow Ontario

60 Bristol Road East, Suite 460
Mississauga, Ontario L4Z 3K8
Canada
Phone: 905-979-3507
FAX: 905-979-4296

Quebec and Atlantic Canada

Watlow Quebec & Atlantic Canada

C.P. 68084
Blainville, Quebec J7C 4Z4 Canada
Phone: 450-433-1309
FAX: 450-433-0457

Western Canada

Watlow Western Canada

9912 Lougheed Highway
Burnaby, British Columbia V3J 1N3
Canada
Phone: 604-444-4881
Fax: 604-444-4883

European Sales Offices

France

Watlow France, S.A.R.L.

Immeuble Somag
16 Rue Ampere
Cergy Pointoise 95307
Phone: 33 (1) 3073-2425
FAX: 33 (1) 3073-2875
Sales Territory: France

Germany

Watlow GmbH

Lauchwasenstr. 1
Postfach 1165
76709 Kronau, Germany
Phone: +49-7253-9400-0
FAX: +49-7253-9400

Sales Territory:

All Other European Countries

Italy

Watlow Italy, S.r.l.

Via Meucci 14
20094 Corsico - MI, Italy
Phone: +39-02-4588841
Fax: +39-02-45869954
Sales Territory: Italy

United Kingdom

Watlow Limited

Robey Close Linby Ind. Estate
Linby Nottingham
England, NG15 8AA
Phone: +44 (0) 115 964 0777
FAX: +44 (0) 115 964 0071
Sales Territory: Great Britain, Ireland

Latin American Sales Office

Mexico

Watlow de Mexico S.A. de C.V.

Av. Epigmenio Gonzalez No. 5
Col. Parques Industriales
Querataro CP-76130
Querataro, Mexico
Phone: + 52 442 217-62-35
FAX: + 52 442 217-64-03

Sales Territory: Mexico and Latin America

Corporate Headquarters

Watlow Electric Manufacturing Company

St. Louis, MO
12001 Lackland Road
St. Louis, MO 63146
Phone: 314-878-4600
FAX: 314-434-1020

Sales Territory: All countries and Canadian provinces not specified.

Application Guide

Electric Heaters

Product Overview

This section of the Application Guide is devoted to electric heaters; their different types, methods of use and general calculations for determining specifications. If you're unable to find or determine which type of Watlow heater will best suit your needs, call your nearest Watlow sales representative. Sales offices are listed on the back cover of this Application Guide.

Heaters

Band and Nozzle Heaters

Led by the high performance MI Band heater, the patented, flexible THINBAND® heater and the standard mica band heater for specialized constructions, Watlow's band and nozzle heaters are ideal for every type of plastic processing equipment.

Sheath materials available include stainless steel with mica insulation, stainless steel with mineral insulation and aluminized or zinc steel with mica insulation.



Performance Capabilities

- Maximum operating temperatures to 760°C (1400°F)
- Typical maximum watt densities from 8.5 W/cm² (55 W/in²) to 35.7 W/cm² (230 W/in²)

Applications

- Extruders
- Blown film dies
- Injection molding machines
- Other cylinder heating applications

Cable Heaters

The versatile Watlow cable heater can be formed to a variety of shapes as dictated by its many applications. These small diameter, high performance units are fully annealed and readily bent to your desired configuration.

Sheath materials available include Inconel® and stainless steel.



Performance Capabilities

- Typical maximum watt densities to 4.6 W/cm² (30 W/in²)
- Maximum operating temperatures to 650°C (1200°F)

Applications

- Plastic injection molding nozzles
- Semiconductor manufacturing and wafer processing
- Hot metal forming dies and punches
- Sealing and cutting bars
- Restaurant and food processing equipment
- Cast-in heaters
- Laminating and printing presses
- Air heating
- Heating in a vacuum environment
- Textile manufacturing

Inconel® is a registered trademark of the Special Metals Corporation.

Application Guide

Electric Heaters

Product Overview

Continued

Cartridge Heaters

The Watlow FIREROD® heater enters its 50th year of industry leading expertise as the premier choice in swaged cartridge heating. With premium materials and tight manufacturing controls, the FIREROD heater continues to provide superior heat transfer, uniform temperatures and resistance to oxidation and corrosion in demanding applications and high temperatures.

Sheath materials available are Incoloy® and stainless steel.



Performance Capabilities

- Typical maximum watt densities up to 62 W/cm² (400 W/in²)
- Maximum operating temperatures to 760°C (1400°F)

Applications

- Molds
- Dies
- Platens
- Hot plates
- Sealings
- Fluid heating
- Life sciences
- Aerospace
- Semiconductor
- Foodservice equipment

Cast-in Heaters

When Watlow creates a custom-engineered cast-in product, the result is more than just a heater. It's a "heated part" that becomes a functional component of your equipment, designed in the exact shape and size you need. The IFC heated part consists of a Watlow heater element built into custom metal shapes designed specifically for your application.

Sheath materials available are 319 and 356 aluminum, pure aluminum and IFC (stainless, nickel, Inconel®, aluminum, copper and bronze).



Performance Capabilities

- Typical maximum watt densities to 15.5 W/cm² (100 W/in²)
- Maximum operating temperatures to 400°C (752°F) to 760°C (1400°F) depending on material

Applications

- Semiconductor manufacturing
- Foodservice equipment
- Plastics processing
- Medical equipment
- Hot glue melt
- Circulation heating

Application Guide

Electric Heaters

Product Overview

Continued

Circulation and Process Heaters

Watlow's circulation heaters are compact heating solutions for fluids such as purified and inert gases, supercritical fluids and liquids like de-ionized water for use in semiconductor and electronics industries as well as for general liquid and gas heating applications. Watlow's industrial process heater lines of immersion, circulation and duct heaters are used to heat a myriad of high and low viscosity fluids ranging from de-ionized and process water, oils, solvents, rinse agents, caustic solutions, etc. to process gases like air, nitrogen, purified and inert gases as well.



Applications

- Oil and gas field equipment
- Refineries & petrochemical plants
- Chemical and industrial gas plants
- HVAC duct heating
- Open tanks and heat treat baths
- Textile drying
- Heat transfer and lube oil systems
- Semiconductor processing equipment
- Precision cleaning equipment
- Power generation systems
- Emissions control systems
- Supercritical fluid heating
- In-line water boilers

Ceramic Fiber Heaters

Ceramic fiber heaters integrate a high temperature iron-chrome-aluminum (ICA) heating element wire with ceramic fiber insulation. Numerous stock, standard and/or custom shapes can be provided, achieving the "heated insulation" concept for your high temperature, non-contact applications. The ceramic fiber insulation isolates the high temperatures inside the heated chamber from the outside. The heaters are low mass, fast heating, with high insulation values and the self-supported heating elements that offer some of the highest temperature heating capabilities within the Watlow family of heater designs.

The sheath material available is molded ceramic fiber.



Performance Capabilities

- Typical maximum watt densities to 1.8 W/cm² (11.5 W/in²)
- Maximum operating temperatures to 1205°C (2200°F)

Applications

- High temperature furnaces
- Metal melting, holding and transfer
- Semiconductor processing
- Glass, ceramic and wire processing
- Analytical instrumentation
- Fluidized beds
- Laboratory and R&D
- Other high temperature process applications

Application Guide

Electric Heaters

Product Overview

Continued

Flexible Heaters

Flexible heaters from Watlow are just what the name implies: thin, bendable and shaped to fit your equipment. You can use your imagination to apply heat to the most complex shapes and geometries conceivable without sacrificing efficiency or dependability.

Sheath materials available include silicone rubber, Kapton®, HT foil and neoprene.

Performance Capabilities



- Typical maximum watt densities from 1.7 W/cm² (11 W/in²) to 17.0 W/cm² (110 W/in²)
- Maximum operating temperatures to 595°C (1100°F)

Applications

- Medical equipment such as blood analyzers, respiratory therapy units and hydrotherapy baths
- Freeze protection for military hardware, aircraft instrumentation and hydraulic equipment
- Battery heating
- Foodservice equipment
- Factory bonding / subassemblies
- Any application requiring a flexible shape or design

Multicell Heaters

The multicell heater from Watlow offers independent zone control for precise temperature uniformity, loose fit design for easy insertion in and removal from the equipment and extreme process temperature capability. The heaters are available with up to eight independently controllable zones and one to three internal thermowells for removable sensors. Custom assemblies are available.

Incoloy® sheath material is available.



Performance Capabilities

- Typical maximum watt densities to 6.2 W/cm² (40 W/in²)
- Maximum operating temperatures to 1230°C (2250°F)

Applications

- Super plastic forming and diffusion bonding
- Hot forging dies
- Heated platens
- Furnace applications
- Superheating of air and other gases
- Fluidized beds for heat treating
- Glass forming, bending and tempering
- Long heater needs (1219 cm (40 foot))
- Soil remediation
- Aluminum processing

Application Guide

Electric Heaters

Product Overview

Continued

Polymer Heaters

For the latest in heating technology from Watlow, specify a heated plastic part in your next product. Watlow's heated plastic parts combine resistive heating elements with a wide range of thermoplastic compounds to yield a part that is both heater and structure. Watlow utilizes typical injection molding techniques and patented resistive element construction methods to produce heated plastic parts that are durable, safe and cost-effective.



Performance Capabilities

- Typical maximum open watt densities from 0.08 W/cm² (0.5 W/in²) to 0.59 W/cm² (3.8 W/in²)
- Typical maximum immersion watt densities from 0.62 W/cm² (4.0 W/in²) to 9.30 W/cm² (60 W/in²)
- Maximum operating temperatures to 220°C (428°F)

Applications

- Medical
- Analytical
- Aerospace
- Freeze protection
- Any heated part application requiring a flexible shape
- Battery heating
- Foodservice
- Transportation
- Semiconductor

Radiant Heaters

With Watlow's diverse RAYMAX® heater line, we have a solution for almost any application requiring radiant heat. Our capabilities cover a wide range of needs, from contamination-resistant panel heaters to fast-responding quartz tubes to rugged tubular elements and high temperature ceramic panels.

Incoloy® tubular, molded ceramic fiber, quartz tube and stainless steel emitter strip sheath materials are available.



Performance Capabilities

- Typical maximum watt densities from 4.6 W/cm² (30 W/in²) to 7.0 W/cm² (45 W/in²)
- Maximum operating temperatures to 1095°C (2000°F)

Applications

- Thermoforming
- Food warming
- Paint and epoxy curing
- Heat treating
- High temperature furnaces
- Tempering and annealing processes

Alcryn® is a registered trademark of Ferro Corporation.

Santoprene® is a registered trademark of Advanced Elastomer Systems.

Application Guide

Electric Heaters

Product Overview

Continued

Strip Heaters

Watlow's mica and 375 strip heaters are the versatile solution for a number of applications. They can be bolted or clamped to a solid surface for freeze and moisture protection, food warming and other applications or utilized as a non-contact radiant heater. The 375 finned strip heaters are commonly used for air heating, drying ovens and space heaters.



Performance Capabilities

- Typical maximum watt densities from 7.8 W/cm² (50 W/in²) to 15.5 W/cm² (100 W/in²)
- Maximum operating temperatures to 760°C (1400°F)

Applications

- Dies and molds
- Tank and platen heating
- Thermoforming
- Packaging and sealing equipment
- Ovens
- Food warming equipment
- Vulcanizing presses
- Duct, space and air heaters
- Incubators
- Autoclaves
- Freeze and moisture protection

Thick Film Heaters

Watlow layers thick film resistor and dielectric materials on quartz, stainless steel and ceramic substrates to produce high performance industrial heaters. The thick film heaters provide very fast temperature response and uniformity on a low-profile heater. Thick film heaters are ideal for applications where space is limited, where conventional heaters can't be used, when heat output needs vary across the surface, or in ultra-clean or aggressive chemical applications.



430 stainless steel (open air), 430 stainless steel (immersion), aluminum nitride, quartz (open air) and quartz (clamp-on) sheath materials are available.

Performance Capabilities

- Typical maximum watt densities from 3 W/cm² (20 W/in²) to 27 W/cm² (175 W/in²)
- Maximum operating temperatures to 550°C (1022°F)

Applications

- Ultra pure aggressive chemicals
- Large panel processing
- Analytical equipment
- Foodservice equipment
- Packaging sealing equipment
- Life sciences sterilizers and GC/mass spectroscopy
- Semiconductor wafer process equipment
- Plastics hot runners nozzles and manifolds

Application Guide

Electric Heaters

Product Overview

Continued

Tubular and Process Assemblies

Watlow's WATROD tubular heater elements and flat FIREBAR elements are designed primarily for direct immersion in liquids such as water, oils, solvents and process solutions, molten materials as well as air and gases. By generating all the heat within the liquid or process, these heaters are virtually 100 percent energy efficient. These versatile heaters can also be formed and shaped into various geometries for radiant heating and contact surface heating applications. UL® and CSA component recognized elements available.



Applications

- Furnaces and ovens
- Molten salt baths
- Foodservice equipment
- Semiconductor equipment
- Die casting equipment
- Metal melt and holding
- Fluidized beds
- Boilers
- Radiant heating
- Process air heating
- Drying and warming

Application Guide

Electric Heaters

Most electrical heating problems can be readily solved by determining the heat required to do the job. To do this, the heat requirement must be converted to electrical **power** and the most practical heater can then be selected for the job. Whether the problem is heating solids, liquids or gases, the method, or approach, to determining the **power** requirement is the same. **All** heating problems involve the following steps to their solution:

Define the Heating Problem

Calculate Power Requirements

System Start-up and Operating Power Requirement

System Maintenance Power Requirements

Operating Heat Losses

Power Evaluation

Review System Application Factors

Safe/Permissible Watt Densities

Mechanical Considerations

Operating Environment Factors

Safety Factor

Heater Life Requirements

Electrical Lead Considerations

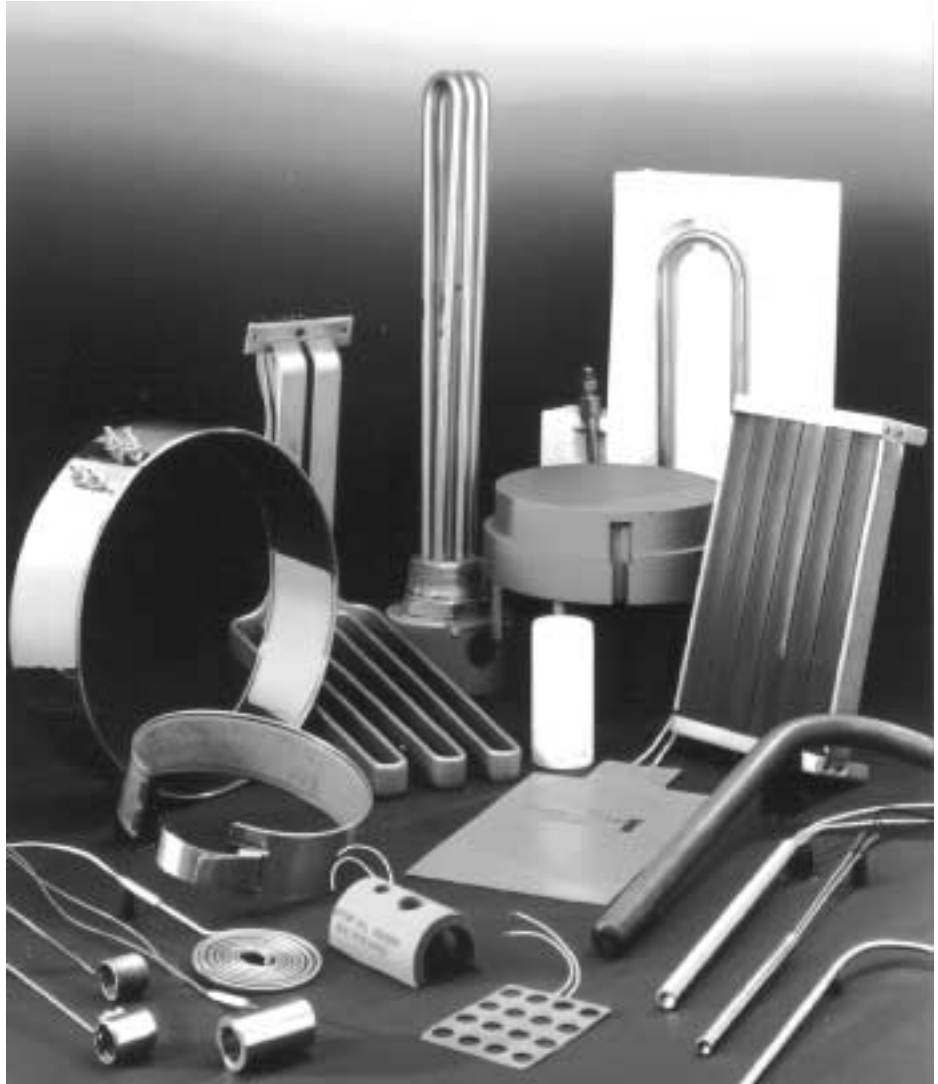

Defining the Problem

Your heating problem must be clearly stated, paying careful attention to defining operating parameters. Gather this application information:

- Minimum start and finish temperatures expected
- Maximum flow rate of material(s) being heated
- Required time for start-up heating and process cycle times

- Weights and dimensions of **both** heated material(s) and containing vessel(s)
- Effects of insulation and its thermal properties
- Electrical requirements—voltage
- Temperature sensing methods and location(s)
- Temperature controller type
- Power controller type
- Electrical limitations

And since the thermal system you're designing may not take into account all the possible or unforeseen heating requirements, don't forget a safety factor. A safety factor increases heater capacity beyond calculated requirements. For details on safety factor, please see "Safety Factor Calculation" under the portion of this section dealing with "Review of Heater Application Factors," on [page 20](#).

Application Guide

Electric Heaters

Power Calculations

Calculations for Required Heat Energy

When performing your own calculations, refer to the Reference Data section (begins on [page 127](#)) for values of materials covered by these equations.

The total heat energy (kWh or Btu) required to satisfy the system needs will be either of the two values shown below depending on which calculated result is larger.

A. Heat Required for Start-Up

B. Heat Required to Maintain the Desired Temperature

The power required (kW) will be the heat energy value (kWh) divided by the required start-up or working cycle time. The kW rating of the heater will be the greater of these values plus a safety factor.

The calculation of start-up and operating requirements consist of several distinct parts that are best handled separately. However, a short method can also be used for a quick estimate of heat energy required. Both methods are defined and then evaluated using the following formulas and methods:

Short Method

Start-up watts = A + C + ½L + Safety Factor

Operating watts = B + D + L + Safety Factor

Safety Factor is normally 10 percent to 35 percent based on application.

A = Watts required to raise the temperature of material and equipment to the operating point, within the time desired

B = Watts required to raise temperature of the material during the working cycle

Equation for A and B (Absorbed watts-raising temperature)

$$\frac{\text{Weight of material (lbs)} \cdot \frac{\text{Specific heat of material}}{\text{(Btu/lb} \cdot \text{°F)}} \cdot \text{temperature rise (°F)}}{\text{Start-up or cycle time (hrs)} \cdot 3.412}$$

C = Watts required to melt or vaporize material during start-up period

D = Watts required to melt or vaporize material during working cycle

Equation for C and D (Absorbed watts-melting or vaporizing)

$$\frac{\text{Weight of material (lbs)} \cdot \text{heat of fusion or vaporization (Btu/lb)}}{\text{Start-up or cycle time (hrs)} \cdot 3.412}$$

L = Watts lost from surfaces by:

- Conduction-use equation below
- Radiation-use heat loss curves
- Convection-use heat loss curves

Equation for L (Lost conducted watts)

$$\frac{\frac{\text{Thermal conductivity of material or insulation (Btu} \cdot \text{in./ft}^2 \cdot \text{°F} \cdot \text{hr)}}{\text{Thickness of material or insulation (in.)}} \cdot \text{Surface area (ft}^2\text{)} \cdot \text{Temp. differential to ambient (°F)}}{3.412}$$

Application Guide

Electric Heaters

Power Calculations— Conduction and Convection Heating

Equation 1 Absorbed Energy, Heat Required to Raise the Temperature of a Material

Because substances all heat differently, different amounts of heat are required in making a temperature change. The specific heat capacity of a substance is the quantity of heat needed to raise the temperature of a unit quantity of the substance by one degree. Calling the amount of heat added Q , which will cause a change in temperature ΔT to a weight of substance W , at a specific heat of material C_p , then $Q = w \cdot C_p \cdot \Delta T$.

Since all calculations are in watts, an additional conversion of $3.412 \text{ Btu} = 1 \text{ Wh}$ is introduced yielding:

Equation 1

$$Q_A \text{ or } Q_B = \frac{w \cdot C_p \cdot \Delta T}{3.412}$$

Q_A = Heat Required to Raise Temperature of Materials During Heat-Up (Wh)

Q_B = Heat Required to Raise Temperature of Materials Processed in Working Cycle (Wh)

w = Weight of Material (lb)

C_p = Specific Heat of Material (Btu/lb · °F)

ΔT = Temperature Rise of Material ($T_{\text{Final}} - T_{\text{Initial}}$)(°F)

This equation should be applied to all materials absorbing heat in the application. Heated media, work being processed, vessels, racks, belts, and ventilation air should be included.

Example: How much heat energy is needed to change the temperature of 50 lbs of copper from 10°F to 70°F?

$$\begin{aligned} Q &= w \cdot C_p \cdot \Delta T \\ &= \frac{(50 \text{ lbs}) \cdot (0.10 \text{ Btu/lb} \cdot \text{°F}) \cdot (60\text{°F})}{3.412} = 88 \text{ (Wh)} \end{aligned}$$

Equation 2 Heat Required to Melt or Vaporize a Material

In considering adding heat to a substance, it is also necessary to anticipate changes in state that might occur during this heating such as melting and vaporizing. The heat needed to melt a material is known as the **latent heat of fusion** and represented by H_f . Another state change is involved in vaporization and condensation. The **latent heat of vaporization** H_v of the substance is the energy required to change a substance from a liquid to a vapor. This same amount of energy is released as the vapor condenses back to a liquid.

Equation 2

$$Q_C \text{ or } Q_D = \frac{w \cdot H_f}{3.412} \quad \text{OR} \quad \frac{w \cdot H_v}{3.412}$$

Q_C = Heat Required to Melt/Vaporize Materials During Heat-Up (Wh)

Q_D = Heat Required to Melt/Vaporize Materials Processed in Working Cycle (Wh)

w = Weight of Material (lb)

H_f = Latent Heat of Fusion (Btu/lb)

H_v = Latent Heat of Vaporization (Btu/lb)

Example: How much energy is required to melt 50 lbs of lead?

$$\begin{aligned} Q &= w \cdot H_f \\ &= \frac{(50 \text{ lbs}) \cdot (9.8 \text{ Btu/lb})}{3.412 \text{ Btu/(Wh)}} = 144 \text{ (Wh)} \end{aligned}$$

Changing state (melting and vaporizing) is a constant temperature process. The C_p value (from Equation 1) of a material also changes with a change in state. Separate calculations are thus required using Equation 1 for the material below and above the phase change temperature.

Application Guide

Electric Heaters

Power Calculations

Continued

Conduction Heat Losses

Heat transfer by conduction is the contact exchange of heat from one body at a higher temperature to another body at a lower temperature, or between portions of the same body at different temperatures.

Equation 3A—Heat Required to Replace Conduction Losses

$$Q_{L1} = \frac{k \cdot A \cdot \Delta T \cdot t_e}{3.412 \cdot L}$$

Q_{L1} = Conduction Heat Losses (Wh)

k = Thermal Conductivity
(Btu · in./ft² · °F · hour)

A = Heat Transfer Surface Area (ft²)

L = Thickness of Material (in.)

ΔT = Temperature Difference Across Material
($T_2 - T_1$) °F

t_e = Exposure Time (hr)

This expression can be used to calculate losses through insulated walls of containers or other plane surfaces **where the temperature of both surfaces can be determined or estimated**. Tabulated values of thermal conductivity are included in the Reference Data section (begins on [page 134](#)).

Convection Heat Losses

Convection is a special case of conduction. Convection is defined as the transfer of heat from a high temperature region in a gas or liquid as a result of movement of the masses of the fluid. The Reference Data section ([page 127](#)) includes graphs and charts showing natural and forced convection losses under various conditions.

Equation 3B—Convection Losses

$$Q_{L2} = A \cdot F_{SL} \cdot C_F$$

Q_{L2} = Convection Heat Losses (Wh)

A = Surface Area (in²)

F_{SL} = Vertical Surface Convection Loss Factor
(W/in²) Evaluated at Surface
Temperature (See Ref. 9, [page 26](#))

C_F = Surface Orientation Factor

Heated surface faces up horizontally = 1.29

Vertical = 1.00

Heated surface faces down horizontally = 0.63

Radiation Heat Losses

For the purposes of this section, graphs are used to estimate radiation losses. Charts in the Reference Data section ([page 127](#)) give emissivity values for various materials. Radiation losses are **not** dependent on orientation of the surface. Emissivity is used to adjust for a material's ability to radiate heat energy.

Equation 3C—Radiation Losses

$$Q_{L3} = A \cdot F_{SL} \cdot e$$

Q_{L3} = Radiation Heat Losses (Wh)

A = Surface Area (in²)

F_{SL} = Blackbody Radiation Loss Factor at Surface Temperature (W/in²)

e = Emissivity Correction Factor of Material Surface

Example:

Using Reference 139, [page 155](#), we find that a blackbody radiator (perfect radiator) at 500°F, has heat losses of 2.5 W/in².

Polished aluminum, in contrast, ($e = 0.09$) only has heat losses of 0.22 W/in² at the same temperature ($2.5 \text{ W/in}^2 \cdot 0.09 = 0.22 \text{ W/in}^2$).

Application Guide

Electric Heaters

Power Calculations

Continued

Combined Convection and Radiation Heat Losses

Some curves in Reference 139 (page 155) combine both radiation and convection losses. This saves you from having to use both Equations 3B and 3C. If only the convection component is required, then the radiation component must be determined separately and subtracted from the combined curve.

Equation 3D—Combined Convection and Radiation Heat Losses

$$Q_{L4} = A \cdot F_{SL}$$

Q_{L4} = Surface Heat Losses Combined Convection and Radiation (Wh)

A = Surface Area (in²)

F_{SL} = Combined Surface Loss Factor at Surface Temperature (W/in²)

This equation assumes a constant surface temperature.

Total Heat Losses

The total conduction, convection and radiation heat losses are summed together to allow for all losses in the power equations. Depending on the application, heat losses may make up only a small fraction of total power required... or it may be the largest portion of the total. Therefore, **do not** ignore heat losses unless previous experience tells you it's alright to do.

Equation 3E—Total Losses

$Q_L = Q_{L1} + Q_{L2} + Q_{L3}$ If convection and radiation losses are calculated separately. (Surfaces are not uniformly insulated and losses must be calculated separately.)

OR

$Q_L = Q_{L1} + Q_{L4}$ If combined radiation and convection curves are used. (Pipes, ducts, uniformly insulated bodies.)

Equations 4 and 5 Start-Up and Operating Power Required

Both of these equations estimate required energy and convert it to power. Since power (watts) specifies an energy rate, we can use power to select electric heater requirements. Both the start-up power and the operating power must be analyzed before heater selection can take place.

Equation 4—Start-Up Power (Watts)

$$P_s = \left[\frac{Q_A + Q_C}{t_s} + \frac{2}{3} (Q_L) \right] \cdot (1 + \text{S.F.})$$

Q_A = Heat Absorbed by Materials During Heat-Up (Wh)

Q_C = Latent Heat Absorbed During Heat-Up (Wh)

Q_L = Conduction, Convection, Radiation Losses (Wh)

S.F. = Safety Factor

t_s = Start-Up (Heat-Up) Time Required (hr)

During start-up of a system the losses are zero, and rise to 100 percent at process temperature. A good approximation of actual losses is obtained when heat losses (Q_L) are multiplied by $\frac{2}{3}$.

Equation 5—Operating Power (Watts)

$$P_o = \left[\frac{Q_B + Q_D}{t_c} + (Q_L) \right] \cdot (1 + \text{S.F.})$$

Q_B = Heat Absorbed by Processed Materials in Working Cycle (Wh)

Q_D = Latent Heat Absorbed by Materials Heated in Working Cycle (Wh)

Q_L = Conduction, Convection, Radiation Losses (Wh)

S.F. = Safety Factor

t_c = Cycle Time Required (hr)

Application Guide

Electric Heaters

Power Calculations— Radiant Heating

When the primary mode of heat transfer is radiation, we add a step after Equation 5.

Equation 6 is used to calculate the net radiant heat transfer between two bodies. We use this to calculate either the radiant heater temperature required or (if we know the heater temperature, but not the power required) the maximum power which can be transferred to the load.

Equation 6—Radiation Heat Transfer Between Infinite Size Parallel Surfaces

$$\frac{P_R}{A} = \frac{S (T_1^4 - T_2^4) \left(\frac{1}{e_f} \right) F}{(144 \text{ in}^2/\text{ft}^2) (3.412 \text{ Btu/Wh})}$$

- P_R = Power Absorbed by the Load (watts) - from Equation 4 or 5
- A = Area of Heater (in²) - known or assumed
- S = Stephan Boltzman Constant
= $0.1714 \cdot 10^{-8}$ (Btu/Hr. Sq. Ft. °R⁴)
- T_1 (°R) = Emitter Temperature (°F + 460)
- T_2 (°R) = Load Temperature (°F + 460)
- e_f = Emissivity Correction Factor - see below
- F = Shape Factor (0 to 1.0) - from Reference 139, [page 155](#)

- e_S = Heater Emissivity (from Material Emissivity Tables)
- e_L = Load Emissivity (from Material Emissivity Tables)
- D_S = Heater Diameter
- D_L = Load Diameter

Emissivity Correction Factor (e_f)

- $e_f = \frac{1}{e_S} + \frac{1}{e_L} - 1$ Plane Surfaces
- $e_f = \frac{1}{e_S} + \frac{D_S}{D_L} \left(\frac{1}{e_L} - 1 \right)$ Concentric Cylinders
Inner Radiating Outward
- $e_f = \frac{1}{e_S} + \left(\frac{D_S}{D_L} \cdot \frac{1}{e_L} \right) - 1$ Concentric Cylinders
Outer Radiating Inward

Power Evaluation

After calculating the start-up and operating power requirements, a comparison must be made and various options evaluated.

Shown in Reference 1 are the start-up and operating watts displayed in a graphic format to help you see how power requirements add up.

With this graphic aid in mind, the following evaluations are possible:

- Compare start-up watts to operating watts.
- Evaluate effects of lengthening start-up time such that start-up watts equals operating watts (use timer to start system before shift).

Comparison of Start-Up and Operating Power Requirements

Ref. 1

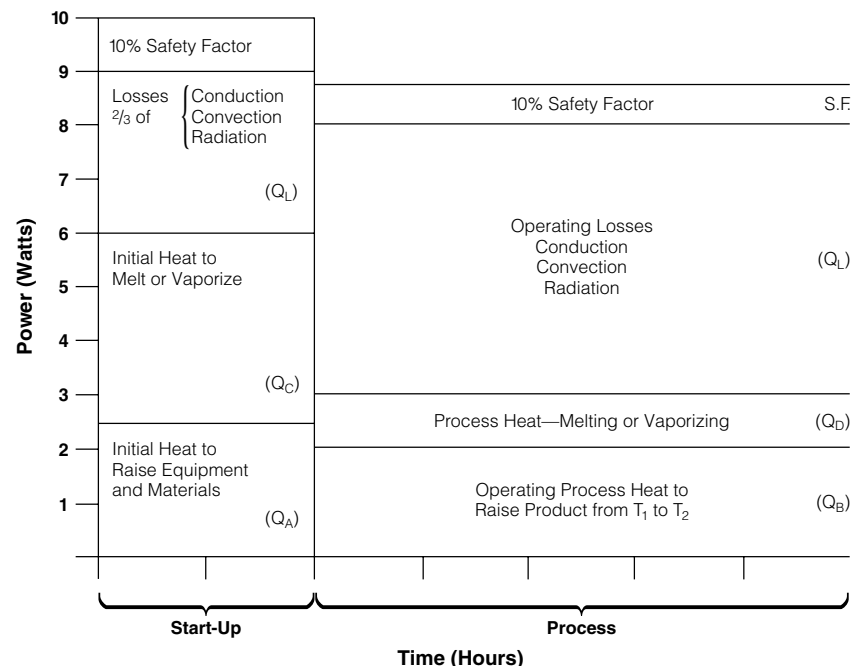

Application Guide

Electric Heaters

Power Evaluation

Continued

- Recognize that more heating capacity exists than is being utilized. (A short start-up time requirement needs more wattage than the process in wattage.)
- Identify where most energy is going and redesign or add insulation to reduce wattage requirements.

Having considered the entire system, a re-evaluation of start-up time, production capacity, and insulating methods should be made.

Review of Heater Application Factors

Safe/Permissible Watt Densities

A heater's watt density rating gives us an indication of how hot a heater will operate. We use this information to establish limits on the application of heaters at various temperatures and under a variety of operating conditions.

The maximum operating watt density is based on applying a heater such that heater life will exceed one year.

In conjunction with desired life, watt density is used to calculate both the required number of heaters and their size.

Silicone Rubber Heater Example: 1000 watts are required for heating a 150°C (300°F) block.

From the silicone rubber heater watt density chart in the flexible heater section of the Watlow Heaters catalog, page 170.

Maximum Watt Density = 16 W/in² for wirewound on-off (2.5 W/in²) or 38 W/in² (6 W/cm²) for etched foil

This means 63 in² of wirewound (five 3 inch • 5 inch heaters) or 27 in² of etched foil (two 3 inch • 5 inch heaters) are required.

Mechanical Considerations

Full access must be provided (in the design process) for ease of heater replacement. This is usually done with shrouds or guards over the heaters.

These guards also serve a secondary purpose in that they may minimize convective heat losses from the back of heaters and increase efficiency of the system.

In all applications where the heater must be attached to a surface, it is extremely important to maintain as intimate a contact as possible to aid heat transfer. Heaters mounted on the exterior of a part should have clamping bands or bolts to facilitate this contact. Heaters inserted in holes should have hole fits as tight as possible. Whenever possible, the holes should exit through the opposite side of the material to facilitate removal of the heater.

Operating Environment Factors

- Contaminants are the primary cause of shortened heater life. Decomposed oils and plastics (hydrocarbons in general), conductive pastes used as anti-seize materials, and molten metals and metal vapors can all create situations that affect heater life. Some heater constructions are better sealed against contaminants than others. In analyzing applications, all possible contaminants must be listed in order to be able to fully evaluate the proposed heater.

Example: Heat is required to maintain molten zinc in the passageways of a zinc die casting machine. The

possible contaminants for this application are as follows:

- a. molten zinc metal
- b. zinc vapor
- c. hydraulic oils
- d. high temperature anti-seize materials
- e. moisture, if die cooling is aided by water circulation

All of these factors indicate that a highly sealed heater construction is required.

- The corrosiveness of the materials heated, or the materials that will contact the heater must also be taken into consideration. Even if a heater is completely sealed, the

choice of the external sheath material is very important to heater life. A corrosion guide is provided, [page 144](#), and should be consulted in order to avoid using materials that are not compatible with a particular environment.

- Explosive environments generally require that the heater be completely isolated from potentially dangerous areas. This is accomplished by inserting the heater in protective wells and routing the wiring through sealed passage-ways out of the hazardous area. Very close fusing is recommended in these cases to minimize the magnitude of the failure, should it occur.

Application Guide

Electric Heaters

Review of Heater

Application Factors

Continued

Safety Factor Calculation

Heaters should always be sized for a higher value than the calculated figure, often referred to as adding in a safety factor.

Generally speaking, the fewer variables and outside influences—the smaller the safety factor.

Here are some general guidelines:

- 10 percent safety factor for large heating systems or when there are very few unknown variables.
- 20 percent safety factor for small to medium heating systems where you are not 100 percent sure you have accurate information.
- 20 to 35 percent for heating systems where you are making many assumptions.

Heater Life Requirements

Temperature

The higher the temperature, the shorter a heater's service life. Mineral insulated heaters using traditional alloys for resistance elements are subject to the life limiting factor of wire oxidation. The winding wire oxidizes at a rate proportional to the element temperature. If the element temperature is known it is possible to project a heater life as shown on the table in Reference 2.

Below are the estimated life expectancies for mineral insulated heater types: FIREROD®, FIREBAR®, Tubular, MI Cable, MI Strip, MI Band.

Ref. 2

| Internal Element Temperature °C (°F) | Approximate Life |
|---|-------------------|
| 815 (1500) | 3 ½ yrs. |
| 870* (1600)* | 1 yr. (2000 hrs.) |
| 925 (1700) | 4 mos. |
| 980 (1800) | 1 ½ mos. |
| 1040 (1900) | 2 wks. |
| 1095 (2000) | 1 wk. |
| 1150 (2100) | 2 days |

* Application charts and operating recommendations use maximum 870°C (1600°F) internal temperature to insure expected heater life greater than one year.

Heaters utilizing lower temperature insulating materials (silicone rubber and mica) have life limiting factors associated with exceeding the temperature limits of the insulation and with thermal cycling. Flexible heaters and mica strip and band heaters must be properly sized and controlled to minimize the temperature swings during thermal cycling of the elements.

Thermal Cycling

Excessive thermal cycling will accelerate heater failure. The worst cycle rate is one which allows full expansion and full contraction of the heater at a high frequency (approximately 30 to 60 seconds on and off).

Prevent excessive cycling by using solid state relays (SSRs) or SCR power controllers. If using SSRs, set the temperature controller's cycle time to one second. If using SCR power controllers (like Watlow's DIN-A-MITE®), be sure to use the variable time base, burst-firing version.

For Immersion Heaters

Use the Corrosion Guide, [page 144](#), and the Selection Guides in the Tubular Elements and Assemblies

section of the Watlow Heaters catalog, page 262, to ensure that the sheath material and watt density ratings are compatible with the liquid being heated.

Immersion heaters used in tanks should be mounted horizontally near the tank bottom to maximize convective circulation. However, locate the heater high enough to be above any sludge build-up in the bottom of the tank. Vertical mounting is not recommended.

The entire heated length of the heater should be immersed at all times. Do not locate the heater in a restricted space where free boiling or a steam trap could occur.

Scale build-up on the sheath and sludge on the bottom of the tank must be minimized. If not controlled they will inhibit heat transfer to the liquid and possibly cause overheating and failure.

Extreme caution should be taken not to get silicone lubricant on the heated section of the heater. The silicone will prevent the "wetting" of the sheath by the liquid, act as an insulator, and possibly cause the heater to fail.

Application Guide

Electric Heaters

Review of Heater Application Factors

Continued

Electrical Lead Considerations

General considerations in selecting various lead types are:

- Temperature of lead area
- Contaminants in the lead area
- Flexibility required
- Abrasion resistance required
- Relative cost

Temperatures listed indicate actual physical operating limits of various wire types. Wires are sometimes rated by CSA, UL® and other agencies for operating at much lower temperatures. In this case, the rating agency temperature limit is the maximum level at which this wire has been tested. If agency approvals are required, don't exceed their temperature limits.

Lead Characteristics—Ref. 3

| Lead Types | Maximum Lead Area Temperature °C (°F) | Contamination Resistance | Flexibility | Abrasion Resistance | Relative Cost |
|--|--|--------------------------|-------------|---------------------|---------------|
| Lead Protection | | | | | |
| Metal Overbraid | — | Average | Good | Excellent | Moderate |
| Flexible Conduit | — | Good | Average | Excellent | Moderate |
| Lead Insulation | | | | | |
| Ceramic Beads | 650 (1200) | Poor | Poor | Average | High |
| Mica-Glass Braid (Silicone or Teflon® Impregnated) | 540 (1000) | Poor | Good | Average | High |
| Glass Braid (Silicone Impregnated) | 400 (750) | Poor | Good | Average | Low |
| Silicone Rubber | 260 (500) | Good | Good | Poor | Low |
| Teflon® | 260 (500) | Excellent | Good | Good | Low |
| PVC | 65 (150) | Good | Good | Poor | Low |

Teflon® is a registered trademark of E.I. du Pont de Nemours & Company.

UL® is a registered trademark of the Underwriter's Laboratories Inc.

Select Heater

Heater Costs

After calculating wattage required and considering various heater attributes, the scope of possible heater types should be narrowed considerably. Now, several factors not previously examined must be considered before final heater type selection: installation, operation and replacement costs.

Initial Installation Cost

Each heater type has specific installation costs to be considered.

- Machining required—mill, drill, ream
- Materials required—heater, brackets, wiring
- Labor to mount and wire heating elements

Operating Cost

The total system operating cost is a composite of two factors. It is usually best to examine cost on an annual basis:

- Total cost of energy (kW Hours) (\$/kWH)

Replacement Cost

The cost of a new heater, lost production time, removal and installation of the new heater must be considered. Generally, these costs are actually much greater than expected. Heater life must be such that replacement can be scheduled and planned during off-peak production times to avoid lost production.

- Removal of existing heater
- Equipment downtime cost
- Material cost—heater, brackets, wiring
- Labor to remove and install heating elements
- Additional purchasing costs
- Scrap products after heater failure and during restart of process
- Frequency of burnouts

Application Guide

Electric Heaters Select Heater Type, Size and Quantity

Example: A plastic extrusion barrel is operating 40 hours per week. Five band heaters are utilized, 1000 watts each. Energy cost \$0.07/kWH. Assume one shift operation or 2080 hours per year Actual power usage is as follows:

Case 1: Shrouded and Uninsulated = 4.06 kW/H

Annual Energy Cost:

$$2080 \text{ Hours} \cdot 4.06 \text{ kW/H} \cdot \$0.07/\text{kWH} = \$591.00$$

Replacement Cost:

$$5 \text{ Heaters} \cdot \$12.00 \text{ Each} = 60.00$$

$$4 \text{ Hours Labor to Install} \cdot \$20.00/\text{hr} = 80.00$$

$$4 \text{ Hours Lost Production Time} \cdot \$50.00/\text{hr} = \underline{200.00}$$

$$\text{Total/Year} = \underline{\$931.00}$$

Case 2: Shrouded and Insulated = 2.38 kW/H

Annual Energy Cost:

$$2080 \text{ Hours} \cdot 2.38 \text{ kW/H} \cdot \$0.07/\text{kWH} = \$346.00$$

Replacement Cost:

$$\text{Same as Case 1} = \underline{340.00}$$

$$\text{Total/Year} = \underline{\$686.00}$$

Here, the cost of operation is much less when insulation is used.

Application Guide

Electric Heaters

Reference Data

Ohm's Law

Ref. 4

Volts

$$\text{Volts} = \sqrt{\text{Watts} \times \text{Ohms}}$$

$$\text{Volts} = \frac{\text{Watts}}{\text{Amperes}}$$

$$\text{Volts} = \text{Amperes} \times \text{Ohms}$$

Ohms

$$\text{Ohms} = \frac{\text{Volts}}{\text{Amperes}}$$

$$\text{Ohms} = \frac{\text{Volts}^2}{\text{Watts}}$$

$$\text{Ohms} = \frac{\text{Watts}}{\text{Amperes}^2}$$

Amperes

$$\text{Amperes} = \frac{\text{Volts}}{\text{Ohms}}$$

$$\text{Amperes} = \frac{\text{Watts}}{\text{Volts}}$$

$$\text{Amperes} = \sqrt{\frac{\text{Watts}}{\text{Ohms}}}$$

Watts

$$\text{Watts} = \frac{\text{Volts}^2}{\text{Ohms}}$$

$$\text{Watts} = \text{Amperes}^2 \times \text{Ohms}$$

$$\text{Watts} = \text{Volts} \times \text{Amperes}$$

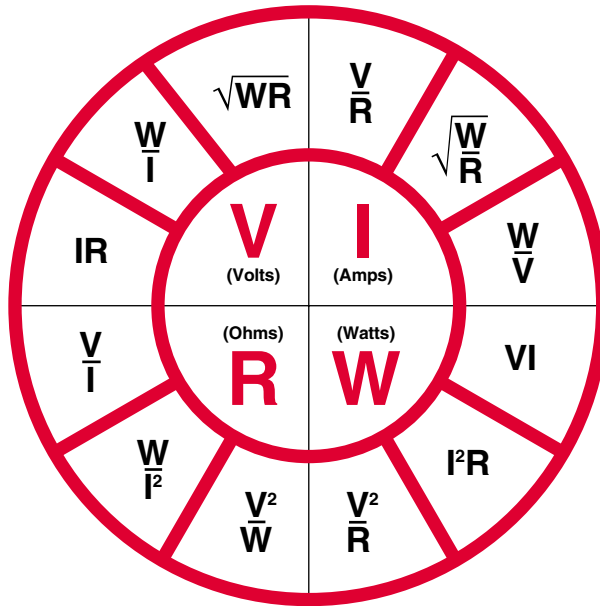

Wattage varies directly as ratio of voltages squared

$$W_2 = W_1 \times \left(\frac{V_2}{V_1}\right)^2$$

$$\text{3 Phase Amperes} = \frac{\text{Total Watts}}{\text{Volts} \times 1.732}$$

Application Guide

Electric Heaters

Reference Data

Continued

Typical 3-Phase Wiring Diagrams and Equations for Resistive Heaters

Definitions

For Both Wye and Delta (Balanced Loads)

- V_P = Phase Voltage
- V_L = Line Voltage
- I_P = Phase Current
- I_L = Line Current
- $R = R_1 = R_2 = R_3 =$
Resistance of each branch
- W = Wattage

Wye and Delta Equivalents

- $W_{DELTA} = 3 W_{WYE}$
- $W_{ODELTA} = \frac{3}{8} W_{DELTA}$
- $W_{OWYE} = \frac{1}{2} W_{WYE}$

3-Phase Wye (Balanced Load)

Ref. 5

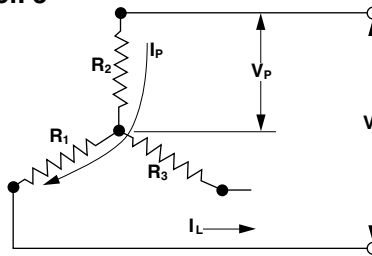

Equations For Wye Only

$$I_P = I_L$$

$$V_P = V_L/1.73$$

$$W_{WYE} = V_L^2/R = 3(V_P^2)/R$$

$$W_{WYE} = 1.73 V_L I_L$$

3-Phase Open Wye (No Neutral)

Ref. 6

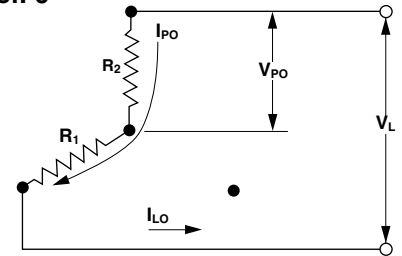

Equations For Open Wye Only (No Neutral)

$$I_{PO} = I_{LO}$$

$$V_{PO} = V_L/2$$

$$W_{OWYE} = \frac{1}{2} (V_L^2/R)$$

$$W_{OWYE} = 2 (V_{PO}^2/R)$$

3-Phase Delta (Balanced Load)

Ref. 7

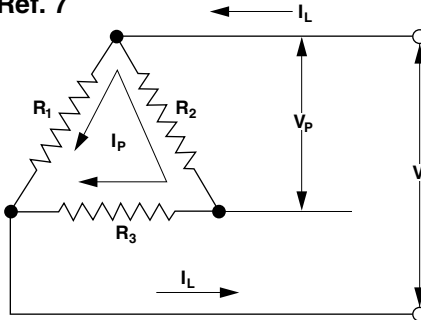

Equations For Delta Only

$$I_P = I_L/1.73$$

$$V_P = V_L$$

$$W_{DELTA} = 3 (V_L^2)/R$$

$$W_{DELTA} = 1.73 V_L I_L$$

3-Phase Open Delta

Ref. 8

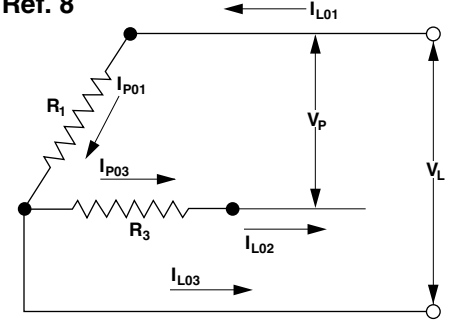

Equations For Open Delta Only

$$V_P = V_L$$

$$I_{PO1} = I_{PO3} = I_{LO2}$$

$$I_{LO3} = 1.73 I_{PO1}$$

$$W_{ODELTA} = 2 (V_L^2/R)$$

Application Guide

Electric Heaters

Heat Loss Factors and Graphs

Heat Losses at 70°F Ambient

How to use the graph for more accurate calculations

Ref. 9—Convection curve correction factors:

| | |
|---|---|
| For losses from top surfaces or from horizontal pipes | Multiply convection curve value by 1.29 |
|---|---|

| | |
|--------------------------------------|-------------------------------|
| For side surfaces and vertical pipes | Use convection curve directly |
|--------------------------------------|-------------------------------|

| | |
|---------------------|---|
| For bottom surfaces | Multiply convection curve value by 0.63 |
|---------------------|---|

Radiation Curve Correction Factors

The radiation curve shows losses from a perfect blackbody and are not dependent upon position. Commonly used block materials lose less heat by radiation than a blackbody, so correction factors are applied. These corrections are the emissivity (e) values listed to the right:

Total Heat Losses =

Radiation losses (curve value times e)
 + Convection losses (top)
 + Convection losses (sides)
 + Convection losses (bottom)
 = Conduction losses (where applicable)

Ref. 9

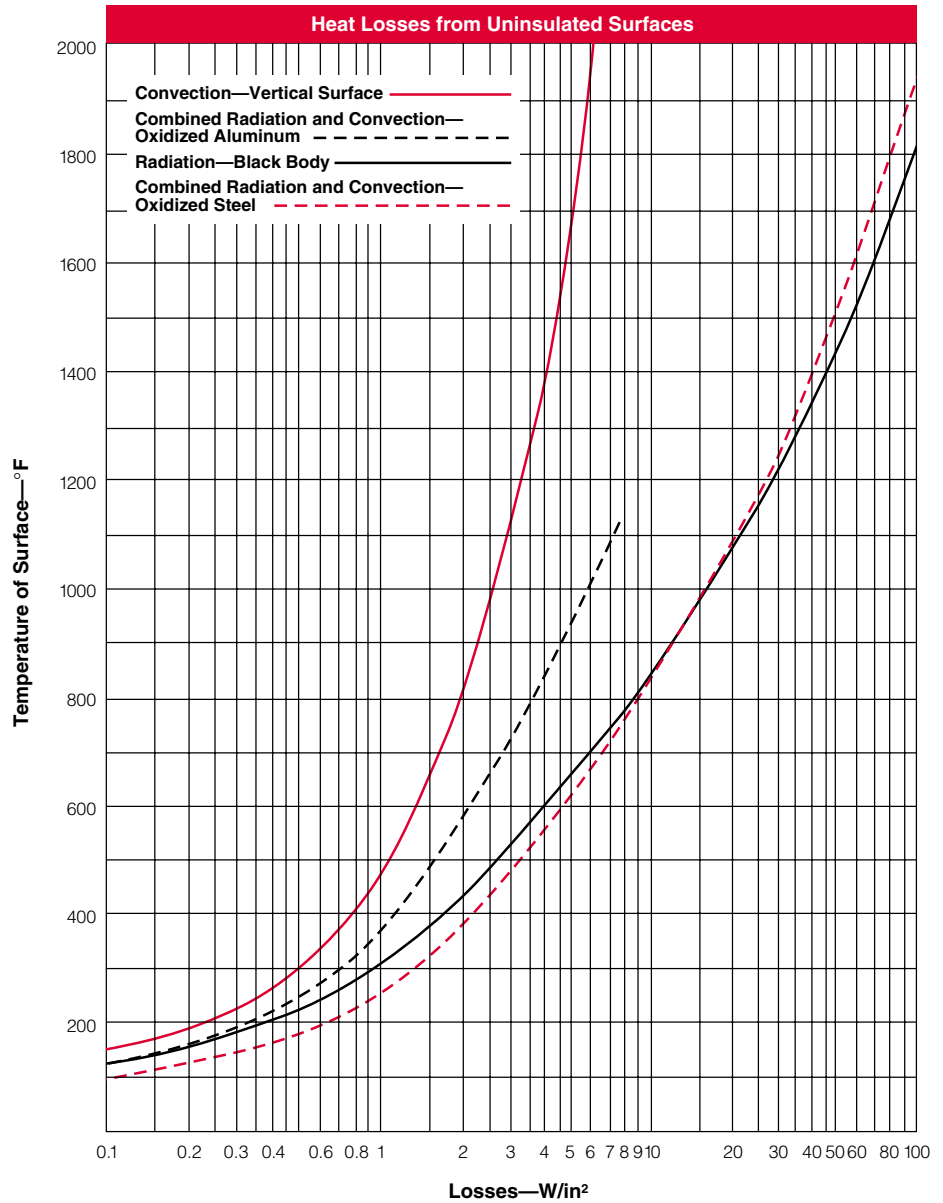

Application Guide

Electric Data

Heat Loss Factors and Graphs

Continued

Helpful Hint: The graphs for losses from **uninsulated** and **insulated** surfaces are hard to read at low temperatures close to ambient. Here are two easy-to-use calculations that are only rule-of-thumb approximations when used within the limits noted.

Rule #1: Losses from an **uninsulated** surface (with an emissivity close to 1.0): (This applies only to temperatures between ambient and about 250°F)

$$\text{Losses (W/in}^2\text{)} = \frac{\Delta T \text{ (}^\circ\text{F) rise above ambient}}{200}$$

Rule #2: Losses from an **insulated** surface: (This insulation is assumed to be one inch thick and have a K-value of about 0.5 Btu-in/hr - ft²-°F. Use only for surfaces less than 800°F.)

$$\text{Losses (W/in}^2\text{)} = \frac{\Delta T \text{ (}^\circ\text{F) rise above ambient}}{950}$$

Some Material Emissivities/Metals—Ref. 10

| Material | Specific Heat Btu/lb-°F | Emissivity | | |
|-----------------|----------------------------|------------------|--------------|-------------|
| | | Polished Surface | Medium Oxide | Heavy Oxide |
| Blackbody | | | 0.75 | 1.00 |
| Aluminum | 0.24 | 0.09 | 0.11 | 0.22 |
| Brass | 0.10 | 0.04 | 0.35 | 0.60 |
| Copper | 0.10 | 0.04 | 0.03 | 0.65 |
| Incoloy® 800 | 0.12 | 0.20 | 0.60 | 0.92 |
| Inconel® 600 | 0.11 | 0.20 | 0.60 | 0.92 |
| Iron, Cast | 0.12 | — | 0.80 | 0.85 |
| Lead, solid | 0.03 | — | 0.28 | — |
| Magnesium | 0.23 | — | — | — |
| Nickel 200 | 0.11 | — | — | — |
| Nichrome, 80-20 | 0.11 | — | — | — |
| Solder, 50-50 | 0.04 | — | — | — |
| Steel | | | | |
| mild | 0.12 | 0.10 | 0.75 | 0.85 |
| stainless 304 | 0.11 | 0.17 | 0.57 | 0.85 |
| stainless 430 | 0.11 | 0.17 | 0.57 | 0.85 |
| Tin | 0.056 | — | — | — |
| Zinc | 0.10 | — | 0.25 | — |

Some Material Emissivities/Non-Metals—Ref. 11

| Material | Specific Heat Btu/lb-°F | Emissivity |
|-----------------|----------------------------|--------------------------|
| Asbestos | 0.25 | Most non-metals: 0.90 |
| Asphalt | 0.40 | |
| Brickwork | 0.22 | |
| Carbon | 0.20 | |
| Glass | 0.20 | |
| Paper | 0.45 | |
| Plastic | 0.2-0.5 | |
| Rubber | 0.40 | |
| Silicon Carbide | 0.20-0.23 | |
| Textiles | — | |
| Wood, Oak | 0.57 | |

Additional information on emissivities is available from Watlow.

Incoloy® and Inconel® are registered trademarks of the Special Metals Corporation.

Application Guide

Electric Heaters

Heat Loss Factors and Graphs

Continued

1. Based upon combined natural convection and radiation losses into 70°F environment.
2. Insulation characteristics
 $k = 0.67 @ 200^\circ\text{F}$
 $k = 0.83 @ 1000^\circ\text{F}$.
3. For molded ceramic fiber products and packed or tightly packed insulation, losses will be lower than values shown.
 For 2 or 3 inches Insulation multiply by 0.84
 For 4 or 5 inches Insulation multiply by 0.81
 For 6 inches Insulation multiply by 0.79

Ref. 12

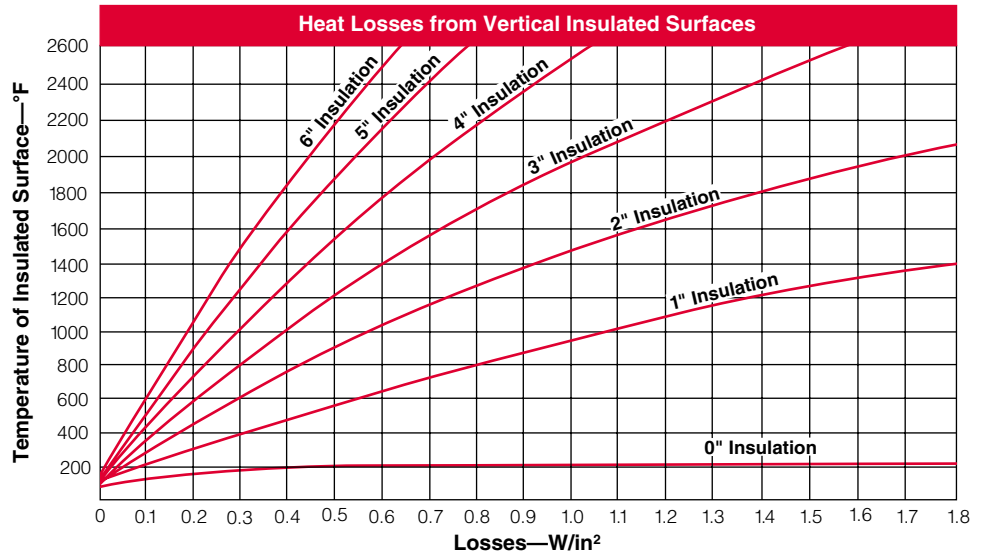

Ref. 13

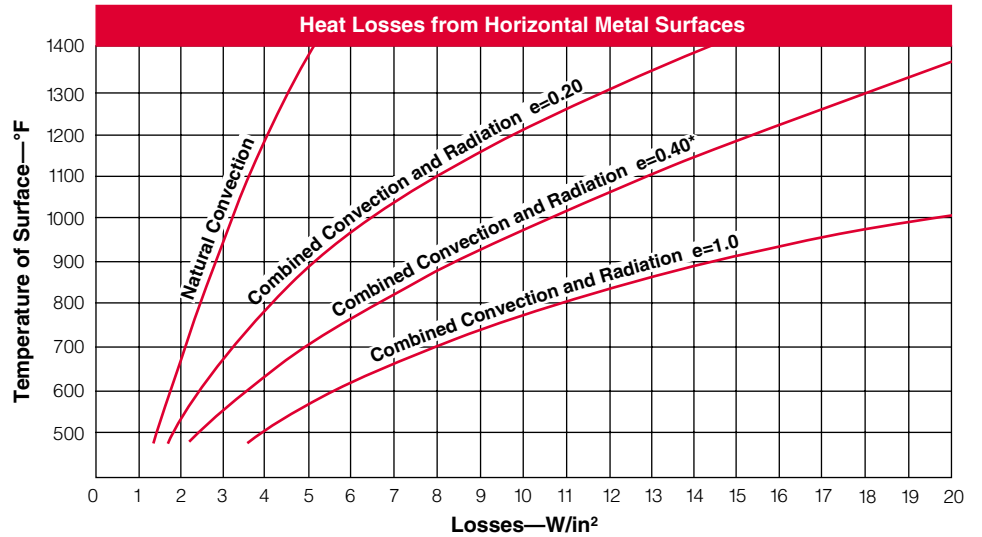

Ref. 14

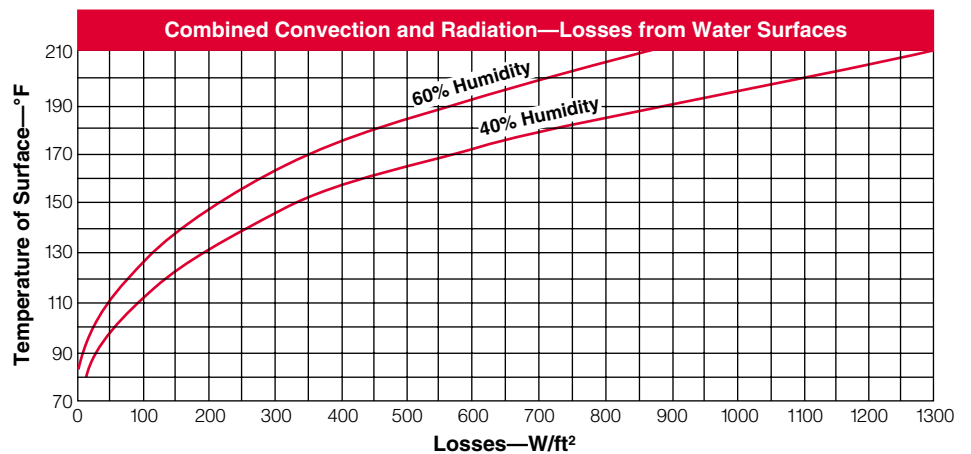

* For losses of molten metal surfaces, use the curve $e=0.40$.

Application Guide

Electric Heaters

Heat Loss Factors and Graphs

Continued

Ref. 15

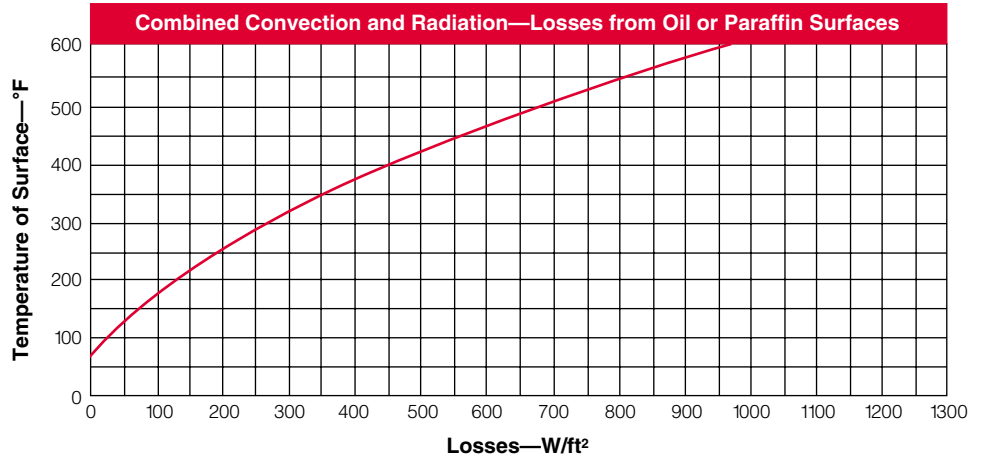

Ref. 16

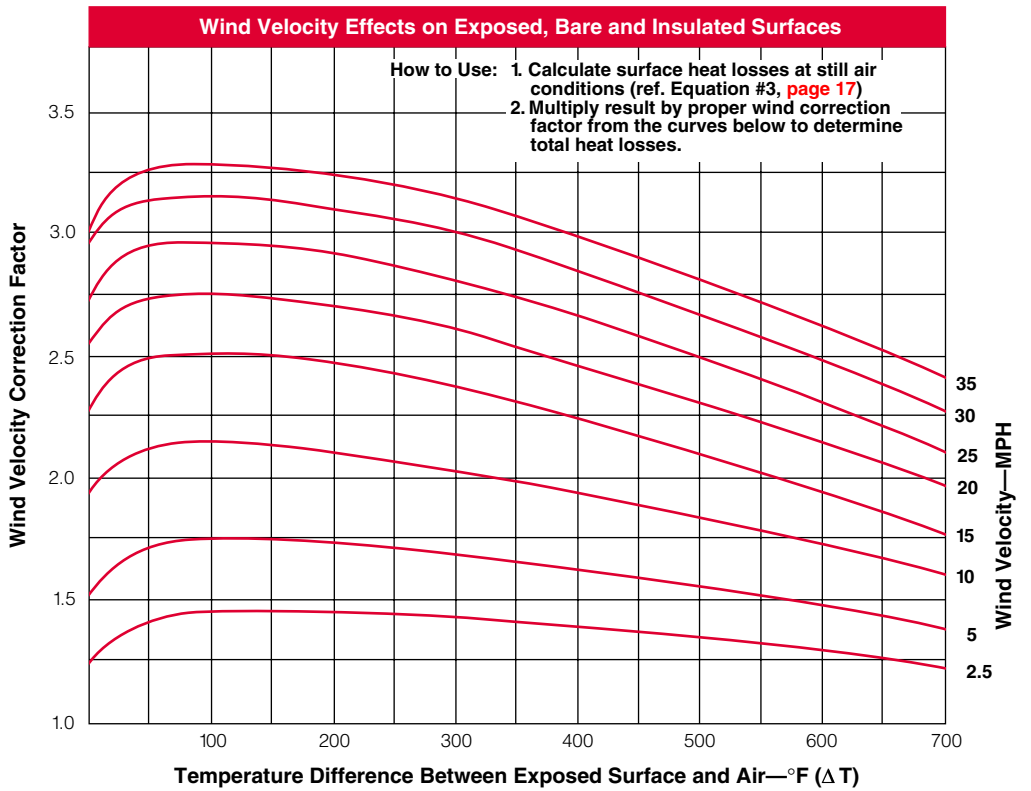

Application Guide

Electric Heaters

Quick Estimates of Wattage Requirements

The following tables can be used to make quick estimates of wattage requirements.

For Steel: Use table or metric equation.

$$kW = \frac{\text{Kilograms} \times \text{Temperature Rise } (^{\circ}\text{C})}{5040 \times \text{Heat-up Time (hrs.)}}$$

$$kW = \frac{\text{Pounds} \times \text{Temperature Rise } (^{\circ}\text{F})}{20,000 \times \text{Heat-up Time (hrs.)}}$$

Kilowatt-Hours to Heat Steel*—Ref. 17

| Amount of Steel (lb.) | Temperature Rise °F | | | | | | |
|-----------------------|--------------------------------------|------|-------|-------|-------|-------|-------|
| | 50° | 100° | 200° | 300° | 400° | 500° | 600° |
| | Kilowatts to Heat in One Hour | | | | | | |
| 25 | 0.06 | 0.12 | 0.25 | .37 | 0.50 | 0.65 | 0.75 |
| 50 | 0.12 | 0.25 | 0.50 | .75 | 1.00 | 1.25 | 1.50 |
| 100 | 0.25 | 0.50 | 1.00 | 1.50 | 2.00 | 2.50 | 3.00 |
| 150 | 0.37 | 0.75 | 1.50 | 2.25 | 3.00 | 3.75 | 4.50 |
| 200 | 0.50 | 1.00 | 2.00 | 3.00 | 4.00 | 5.00 | 6.00 |
| 250 | 0.65 | 1.25 | 2.50 | 3.75 | 5.00 | 6.25 | 7.50 |
| 300 | 0.75 | 1.50 | 3.00 | 4.50 | 6.00 | 7.50 | 9.00 |
| 400 | 1.00 | 2.00 | 4.00 | 6.00 | 8.00 | 10.00 | 12.00 |
| 500 | 1.25 | 2.50 | 5.00 | 7.50 | 10.00 | 12.50 | 15.00 |
| 600 | 1.50 | 3.00 | 6.00 | 9.00 | 12.00 | 15.00 | 18.00 |
| 700 | 1.75 | 3.50 | 7.00 | 10.50 | 14.00 | 17.50 | 21.00 |
| 800 | 2.00 | 4.00 | 8.00 | 12.00 | 16.00 | 20.00 | 24.00 |
| 900 | 2.25 | 4.50 | 9.00 | 13.50 | 18.00 | 22.50 | 27.00 |
| 1000 | 2.50 | 5.00 | 10.00 | 15.00 | 20.00 | 25.00 | 30.00 |

* Read across in table from nearest amount in pounds of steel to desired temperature rise column and note kilowatts to heat in one hour.

Includes a 40 percent safety factor to compensate for high heat losses and/or low power voltage.

For Oil:

Use equation or table.

$$kW = \frac{\text{Gallons} \times \text{Temperature Rise } (^{\circ}\text{F})}{800 \times \text{Heat-up time (hrs.)}}$$

OR

$$kW = \frac{\text{Liters} \times \text{Temperature Rise } (^{\circ}\text{C})}{1680 \times \text{Heat-up time (hrs.)}}$$

1 cu. ft. = 7.49 gallons

Kilowatt-Hours to Heat Oil*—Ref. 18

| Amount of Oil | | Temperature Rise °F | | | | | |
|---------------|---------|---------------------|------|------|------|------|------|
| Cubic Feet | Gallons | 50° | 100° | 200° | 300° | 400° | 500° |
| 0.5 | 3.74 | 0.3 | 0.5 | 1 | 2 | 2 | 3 |
| 1.0 | 7.48 | 0.5 | 1.0 | 2 | 3 | 4 | 6 |
| 2.0 | 14.96 | 1.0 | 1.0 | 2 | 4 | 6 | 11 |
| 3.0 | 22.25 | 2.0 | 3.0 | 6 | 9 | 12 | 16 |
| 4.0 | 29.9 | 2.0 | 4.0 | 8 | 12 | 16 | 22 |
| 5.0 | 37.4 | 3.0 | 4.0 | 9 | 15 | 20 | 25 |
| 10.0 | 74.8 | 5.0 | 9.0 | 18 | 29 | 40 | 52 |
| 15.0 | 112.5 | 7.0 | 14.0 | 28 | 44 | 60 | 77 |
| 20.0 | 149.6 | 9.0 | 18.0 | 37 | 58 | 80 | 102 |
| 25.0 | 187 | 11.0 | 22.0 | 46 | 72 | 100 | 127 |
| 30.0 | 222.5 | 13.0 | 27.0 | 56 | 86 | 120 | 151 |
| 35.0 | 252 | 16.0 | 31.0 | 65 | 100 | 139 | 176 |
| 40.0 | 299 | 18.0 | 36.0 | 74 | 115 | 158 | 201 |
| 45.0 | 336.5 | 20.0 | 40.0 | 84 | 129 | 178 | 226 |
| 50.0 | 374 | 22.0 | 45.0 | 93 | 144 | 197 | 252 |
| 55.0 | 412 | 25.0 | 49.0 | 102 | 158 | 217 | 276 |
| 60.0 | 449 | 27.0 | 54.0 | 112 | 172 | 236 | 302 |
| 65.0 | 486 | 29.0 | 58.0 | 121 | 186 | 255 | 326 |
| 70.0 | 524 | 32.0 | 62.0 | 130 | 200 | 275 | 350 |
| 75.0 | 562 | 34.0 | 67.0 | 140 | 215 | 294 | 375 |

* Read across in table from nearest amount in gallons of liquids to desired temperature rise column and note kilowatts to heat in one hour.

Add 5 percent for uninsulated tanks.

Application Guide

Electric Heaters

Quick Estimates of Wattage Requirements

Continued

* Read across in table from nearest amount in gallons of liquid to desired temperature rise column and note kilowatts to heat in one hour.

For Heating Flowing Water:

$$kW = GPM \times \text{Temperature Rise } (^\circ F) \times 0.16$$

OR

$$kW = \text{Liters/min.} \times \text{Temperature Rise } (^\circ C) \times 0.076$$

For Heating Water in Tanks: Use equation or table.

$$kW = \frac{\text{Gallons} \times \text{Temperature Rise } (^\circ F)}{375 \times \text{Heat-up Time (hrs)}}$$

OR

$$kW = \frac{\text{Liters} \times \text{Temperature Rise } (^\circ C)}{790 \times \text{Heat-up Time (hrs)}}$$

1 cu. ft. = 7.49 gallons

Kilowatt-Hours to Heat Water*—Ref. 19

| Amount of Liquid | | Temperature Rise °F | | | | | | |
|-------------------------------|---------|---------------------|------|------|-------|-------|-------|-------|
| ft ³ | Gallons | 20° | 40° | 60° | 80° | 100° | 120° | 140° |
| Kilowatts to Heat in One Hour | | | | | | | | |
| 0.66 | 5 | 0.3 | 0.5 | 0.8 | 1.1 | 1.3 | 1.6 | 1.9 |
| 1.3 | 10 | 0.5 | 1.1 | 1.6 | 2.1 | 2.7 | 3.2 | 3.7 |
| 2.0 | 13 | 0.8 | 1.6 | 2.4 | 3.2 | 4.0 | 4.8 | 5.6 |
| 2.7 | 20 | 1.1 | 2.2 | 3.2 | 4.3 | 5.3 | 6.4 | 7.5 |
| 3.3 | 25 | 1.3 | 2.7 | 4.0 | 5.3 | 6.7 | 8.0 | 9.3 |
| 4.0 | 30 | 1.6 | 3.2 | 4.8 | 6.4 | 8.0 | 9.6 | 12.0 |
| 5.3 | 40 | 2.1 | 4.0 | 6.4 | 8.5 | 11.0 | 13.0 | 15.0 |
| 6.7 | 50 | 2.7 | 5.4 | 8.0 | 10.7 | 13.0 | 16.0 | 19.0 |
| 8.0 | 60 | 3.3 | 6.4 | 9.6 | 12.8 | 16.0 | 19.0 | 22.0 |
| 9.4 | 70 | 3.7 | 7.5 | 11.2 | 15.0 | 19.0 | 22.0 | 26.0 |
| 10.7 | 80 | 4.3 | 8.5 | 13.0 | 17.0 | 21.0 | 26.0 | 30.0 |
| 12.0 | 90 | 5.0 | 10.0 | 14.5 | 19.0 | 24.0 | 29.0 | 34.0 |
| 13.4 | 100 | 5.5 | 11.0 | 16.0 | 21.0 | 27.0 | 32.0 | 37.0 |
| 16.7 | 125 | 7.0 | 13.0 | 20.0 | 27.0 | 33.0 | 40.0 | 47.0 |
| 20.0 | 150 | 8.0 | 16.0 | 24.0 | 32.0 | 40.0 | 48.0 | 56.0 |
| 23.4 | 175 | 9.0 | 18.0 | 28.0 | 37.0 | 47.0 | 56.0 | 65.0 |
| 26.7 | 200 | 11.0 | 21.0 | 32.0 | 43.0 | 53.0 | 64.0 | 75.0 |
| 33.7 | 250 | 13.0 | 27.0 | 40.0 | 53.0 | 67.0 | 80.0 | 93.0 |
| 40.0 | 300 | 16.0 | 32.0 | 47.0 | 64.0 | 80.0 | 96.0 | 112.0 |
| 53.4 | 400 | 21.0 | 43.0 | 64.0 | 85.0 | 107.0 | 128.0 | 149.0 |
| 66.8 | 500 | 27.0 | 53.0 | 80.0 | 107.0 | 133.0 | 160.0 | 187.0 |

Electric Heaters

Kilowatt-Hours to Superheat Steam Ref. 20

- Plot points on lines P, Q and S.
P represents the inlet temperature (and saturation pressure) of the system.
Q represents the liquid content of the water vapor.
S indicates the outlet temperature minus the saturated temperature.
W indicates the heat content of the water vapor.
- Draw a straight line from P through Q to W. Read W₁.
- Draw a straight line from P through S to W. Read W₂.
- Required watts = Weight (lbs.) of steam/hour x (W₂-W₁)

Watt density is critical. Review temperature and velocity prior to heater selection.

Reference is 80 percent quality at 20 psig.

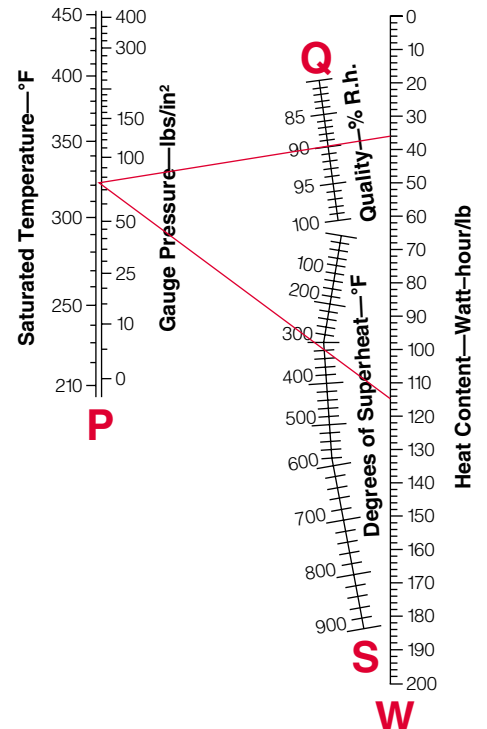

Application Guide

Electric Heaters

Quick Estimates of Wattage Requirements

Continued

Kilowatt-Hours to Heat Air—Ref. 21

| Amt. of Air CFM | Temperature Rise °F | | | | | | | | | | |
|-----------------|---------------------|------|------|------|-------|-------|-------|-------|-------|-------|-------|
| | 50° | 100° | 150° | 200° | 250° | 300° | 350° | 400° | 450° | 500° | 600° |
| 100 | 1.7 | 3.3 | 5.0 | 6.7 | 8.3 | 10.0 | 11.7 | 13.3 | 15.0 | 16.7 | 20.0 |
| 200 | 3.3 | 6.7 | 10.0 | 13.3 | 16.7 | 20.0 | 23.3 | 26.7 | 30.0 | 33.3 | 40.0 |
| 300 | 5.0 | 10.0 | 15.0 | 20.0 | 25.0 | 30.0 | 35.0 | 40.0 | 45.0 | 50.0 | 60.0 |
| 400 | 6.7 | 13.3 | 20.0 | 26.7 | 33.3 | 40.0 | 46.7 | 53.3 | 60.0 | 66.7 | 80.0 |
| 500 | 8.3 | 16.7 | 25.0 | 33.3 | 41.7 | 50.0 | 58.3 | 66.7 | 75.0 | 83.3 | 100.0 |
| 600 | 10.0 | 20.0 | 30.0 | 40.0 | 50.0 | 60.0 | 70.0 | 80.0 | 90.0 | 100.0 | 120.0 |
| 700 | 11.7 | 23.3 | 35.0 | 46.7 | 58.3 | 70.0 | 81.7 | 93.3 | 105.0 | 116.7 | 140.0 |
| 800 | 13.3 | 26.7 | 40.0 | 53.3 | 66.7 | 80.0 | 93.3 | 106.7 | 120.0 | 133.3 | 160.0 |
| 900 | 15.0 | 30.0 | 45.0 | 60.0 | 75.0 | 90.0 | 105.0 | 120.0 | 135.0 | 150.0 | 180.0 |
| 1000 | 16.7 | 33.3 | 50.0 | 66.7 | 83.3 | 100.0 | 116.7 | 133.3 | 150.0 | 166.7 | 200.0 |
| 1100 | 18.3 | 36.7 | 55.0 | 73.3 | 91.7 | 110.0 | 128.3 | 146.7 | 165.0 | 183.3 | 220.0 |
| 1200 | 20.0 | 40.0 | 60.0 | 80.0 | 100.0 | 120.0 | 140.0 | 160.0 | 180.0 | 200.0 | 240.0 |

Use the maximum anticipated airflow. This equation assumes insulated duct (negligible heat loss), 70°F inlet air and 14.7 psia.

For Air:

Use equation or table.

$$kW = \frac{CFM * \text{Temperature Rise (°F)}}{3000}$$

OR

$$kW = \frac{\text{Cubic Meters/Min} * \text{Temperature Rise (°C)}}{47}$$

For Compressed Air:

$$kW = \frac{CFM^{**} * \text{Density}^{**} * \text{Temperature Rise (°F)}}{228}$$

OR

$$kW = \frac{\text{Cubic Meters/Min}^{**} * \text{Temperature Rise (°C)} * \text{Density (kg/m}^3\text{)}^{**}}{57.5}$$

*Measured at normal temperature and pressure.

**Measured at heater system inlet temperature and pressure.

Application Guide

The Art of Temperature Sensing

Defining Temperature—What Is It?

Temperature is the degree of “hotness” or “coldness” of a body or substance as indicated on, or referenced to a standard scale.

Another way to think of temperature is in terms of heat energy. Heat energy is the amount of molecular activity which is the sum of an atom’s subatomic particle vibration, oscillation and friction with other subatomic particles in the same molecule.

The greater the molecular activity, the greater the amount of heat energy. Conversely, less molecular activity results in less heat energy.

The theoretical point, or “temperature,” at which there is no molecular activity is called absolute zero.

To measure “temperature” or the relative amount of heat energy, temperature scales have been devised to define arbitrary increments.

There are four temperature scales commonly in use today:

- Celsius—commonly used throughout the world
[$^{\circ}\text{C} = \frac{5}{9} (^{\circ}\text{F} - 32)$]
- Kelvin—used in conjunction with the Celsius scale for scientific and engineering equations
[$\text{K} = \frac{5}{9} (^{\circ}\text{R} - 0.6^{\circ})$; $\text{K} = ^{\circ}\text{C} + 273$]
- Fahrenheit—commonly used in North America ($^{\circ}\text{F} = 1.8^{\circ}\text{C} + 32$)
- Rankine—used in conjunction with the Fahrenheit scale for scientific and engineering equations
[$^{\circ}\text{R} = 1.8\text{K} + 0.6^{\circ}$; $^{\circ}\text{R} = ^{\circ}\text{F} + 460^{\circ}$]



Temperature Sensing Methods

Contact temperature sensing

brings the sensor in physical contact with a substance or object. Contact sensing can be used with solids, liquids or gases.

Non-contact temperature sensing

(infrared temperature sensing or IR sensing) measures temperature by intercepting a portion of the electromagnetic energy emitted by an object

or substance (most notably the energy contained in the infrared portion of the electromagnetic spectrum) and detecting its intensity. This method is used to sense the temperatures of solids and liquids. IR sensors cannot be used to sense the temperature of gases due to their transparent nature.

Application Guide

The Art of Temperature Sensing

Product Overview

Sensors

Thermocouples

Watlow provides more than 80 years of manufacturing, research and quality for your temperature sensing needs. A tremendous selection of general application, mineral insulated metal sheathed, base and noble metal thermocouples are available.

Fiberglass insulated thermocouples are capable of temperatures up to 480°C (900°F) for continuous operation. Watlow provides grounded, ungrounded and exposed junctions, same day delivery on millions of products and custom manufactured thermocouples.



Applications

- Plastic injection molding machinery
- Food processing equipment
- Engine and turbine exhaust gas
- Semiconductor processing
- Heat treating and metals processing
- Medical equipment
- Aerospace industries
- Packaging equipment
- Test stands

RTDs and Thermistors

Watlow's platinum resistance elements are specially designed to ensure precise and repeatable temperature versus resistance measurements. The sensors are made with controlled purity platinum wire and high purity ceramic components, and constructed in a unique strain-free manner.

Watlow RTDs and thermistors are accurate, sensitive, interchangeable, standardized and repeatable.



Performance Capabilities

- Temperature range of -200°C (-328°F) to 650°C (1200°F)
- Specialty RTDs available to 850°C (1560°F)

Applications

- Air conditioning and refrigeration servicing
- Furnace servicing
- Foodservice processing
- Medical research
- Textile production
- Plastics processing
- Petrochemical processing
- Microelectronics
- Air, gas and liquid temperature measurement

Application Guide

The Art of Temperature Sensing

Product Overview

Continued

XACTPAK® Cable

The unique properties of XACTPAK® mineral insulated, metal-sheathed cable make it ideally suited to solve a wide variety of problem applications. The outer sheath protects the thermocouple from oxidation and hostile environments, and the mineral insulation provides excellent high temperature dielectric strength.



XACTPAK cable is fireproof, high pressure rated, cold and thermal shock resistant, gas tight, moisture proof, formable, weldable, corrosion resistant and high temperature rated. Cryogenic cable available upon request.

Diameters are available down to 0.25 mm (0.01 inch). Temperature ranges from 0 to 1480°C (32 to 2700°F).

Applications

- Atomic research / nuclear reactors
- Blast furnaces / vacuum furnaces
- Catalytic reformers
- Diesel engines
- Food and beverage
- Glass and ceramic
- Heat treating
- Jet engines / rocket engines
- Medical
- Power stations / steam generators
- Refineries and oil processing

SERV-RITE® Wire and Cable

Since 1914, Watlow's SERV-RITE® thermocouple wire and thermocouple extension wire have been known for premium performance and reliability. All Watlow Richmond SERV-RITE wire is manufactured under ISO 9001 quality standards.



Insulation temperature ranges from -200 to 1290°C (-328 to 2350°F).

SERV-RITE wire features NIST calibration certificates, solid or stranded wire constructions, wide selection of insulation types, color coding and select metallic overbraids and wraps.

Applications

- Aerospace industries
- Composite component manufacturing
- Automotive
- Cryogenic applications
- Electric power plants
- Food processing
- Glass, ceramic and brick manufacturing
- Laboratories
- Medical equipment
- Petrochemical
- Metal processing

Application Guide

The Art of Temperature Sensing

Contact Temperature Sensor Types and Comparisons

Thermocouples, RTDs and Thermistors

Temperature sensors, aside from capillary/bulb thermometers and bi-metal sensors, use varying voltage signals or resistance values.

Voltage Signals

Sensors generating varying voltage signals are thermocouples. Thermocouples combine dissimilar metallic elements or alloys to produce a voltage. Using specific combinations of metals and alloys in the thermocouple's legs produces a predictable change in voltage based on a change in temperature.

Resistance Values

Sensors generating varying resistance values are resistance temperature

detectors (RTDs) and thermistors. Resistive devices use metals or metal oxides that provide repeatable changes of resistance with temperature.

A variation of the thermistor not covered in this Application Guide is the integrated circuit (IC). It's a thermistor that has a computer chip to condition and amplify its signal. The computer chip limits the IC's use to a narrow temperature range.

Ref. 22

| | Thermocouple | RTD | Thermistor |
|----------------------|--|--|---|
| | | | |
| Advantages | <ul style="list-style-type: none"> • No resistance lead wire problems • Fastest response to temperature changes • Simple, rugged • High temperature operation 1704°C (3100°F) • Point temperature sensing | <ul style="list-style-type: none"> • Most stable, accurate • Contamination resistant • More linear than thermocouple • Area temperature sensing • Most repeatable temperature measurement | <ul style="list-style-type: none"> • High output, fast • Two-wire ohms measurement • Point temperature sensing • High resistance • High sensitivity to small temperature changes |
| Disadvantages | <ul style="list-style-type: none"> • Non-linear • Low voltage • Least stable, repeatable • Least sensitive to small temperature changes | <ul style="list-style-type: none"> • Current source required • Low absolute resistance • Self-heating • Slow response time • Low sensitivity to small temperature changes | <ul style="list-style-type: none"> • Non-linear • Limited temperature range • Fragile • Current source required • Self-heating |

Conclusion

Thermocouples are best suited to high temperatures, environmental extremes, or applications requiring microscopic size sensors.

RTDs are best for most industrial measurements over a wide temperature range, especially when sensor stability is essential for proper control.

Thermistors are best for low temperature applications with limited temperature ranges.

Application Guide

The Art of Temperature Sensing

Thermocouples

As described on the previous page, thermocouples are voltage generating sensors. Their voltage output increases in a predictable manner inside their temperature application range.

Thermocouples are classified by *calibration type* because they have differing EMF (electromotive force) vs. temperature curves. Some generate considerably more voltage at lower temperatures, while others don't begin to develop a significant voltage until

subjected to high temperatures. Also, *calibration types* are designed to deliver as close to a straight line voltage curve inside their temperature application range as possible. This makes it easier for an instrument or temperature controller to correctly correlate the received voltage to a particular temperature.

Additionally, thermocouple *calibration types* have different levels of compatibility with different atmospheres. Chemical reaction between certain thermocouple alloys and the application atmosphere could cause metallurgy degradation, making another *calibration types* more suitable for sensor life and accuracy requirements.

Calibration types have been established by the ASTM and the American National Standard Institute (ANSI) to define their temperature vs. EMF characteristics in accordance with the ITS-90, in standard or special calibrations.

Additionally, there are non-ANSI/ASTM *calibration types*. These thermocouples are made from tungsten and tungsten-rhenium alloys. Generally used for measuring higher temperatures, but limited to use in inert and non-oxidizing atmospheres.

Thermocouple Types – Ref. 23

| Thermocouple Type | Useful/General Application Range | Notes |
|-------------------|----------------------------------|---|
| B | 1370-1700°C (2500-3100°F) | Easily contaminated, require protection. |
| C* | 1650-2315°C (3000-4200°F) | No oxidation resistance. Vacuum, hydrogen or inert atmospheres. |
| E** | 95-900°C (200-1650°F) | Highest output of base metal thermocouples. Not subject to corrosion at cryogenic temperatures. |
| J | 95-760°C (200-1400°F) | Reducing atmosphere recommended. Iron leg subject to oxidation at elevated temperatures—use larger gauge to compensate. |
| K** | 95-1260°C (200-2300°F) | Well suited for oxidizing atmospheres. |
| N | 650-1260°C (1200-2300°F) | For general use, better resistance to oxidation and sulfur than Type K. |
| R | 870-1450°C (1600-2640°F) | Oxidizing atmosphere recommended. Easily contaminated, require protection. |
| S | 980-1450°C (1800-2640°F) | Laboratory standard, highly reproducible. Easily contaminated, require protection. |
| T** | -200-350°C (-330-660°F) | Most stable at cryogenic temperature ranges. Excellent in oxidizing and reducing atmospheres within temperature range. |

*Not an ANSI symbol

**Also suitable for cryogenic applications from -200 to 0°C (-328 to 32°F)

Type E

The Type E thermocouple is suitable for use at temperatures up to 900°C (1650°F) in a vacuum, inert, mildly oxidizing or reducing atmosphere. At

cryogenic temperatures, the thermocouple is not subject to corrosion. This thermocouple has the highest EMF output per degree of all the commonly used thermocouples.

Application Guide

The Art of Temperature Sensing

Thermocouples

Continued

Type J

The Type J may be used, exposed or unexposed, where there is a deficiency of free oxygen. For cleanliness and longer life, a protecting tube is recommended. Since JP (iron) wire will

oxidize rapidly at temperatures over 540°C (1000°F), it is recommended that larger gauge wires be used to compensate. Maximum recommended operating temperature is 760°C (1400°F).

Type K

Due to its reliability and accuracy, Type K is used extensively at temperatures up to 1260°C (2300°F). It's good practice to protect this type of thermocouple with a suitable metal or ceramic protecting tube, especially in reducing atmospheres. In oxidizing

atmospheres, such as electric furnaces, tube protection is not always necessary when other conditions are suitable; however, it is recommended for cleanliness and general mechanical protection. Type K will generally outlast Type J because the JP (iron) wire rapidly oxidizes, especially at higher temperatures.

Type N

This nickel-based thermocouple alloy is used primarily at high temperatures up to 1260°C (2300°F). While not a direct replacement for Type K, Type N

provides better resistance to oxidation at high temperatures and longer life in applications where sulfur is present.

Type T

This thermocouple can be used in either oxidizing or reducing atmospheres, though for longer life a protecting tube is recommended. Because of its stability at lower temperatures,

this is a superior thermocouple for a wide variety of applications in low and cryogenic temperatures. Its recommended operating range is— -200° to 350°C (-330° to 660°F), but it can be used to -269°C (-452°F) (boiling helium).

Types S, R and B

Maximum recommended operating temperature for Type S or R is 1450°C (2640°F); Type B is recommended for use at as high as 1700°C (3100°F). These thermocouples are easily contaminated. Reducing atmospheres are

particularly damaging to the calibration. Noble metal thermocouples should always be protected with a gas-tight ceramic tube, a secondary tube of alumina and a silicon carbide or metal outer tube as conditions require.

W-5 Percent Re/W-26 Percent Re (Type C*)

This refractory metal thermocouple may be used at temperatures up to

2315°C (4200°F). Because it has no resistance to oxidation, its use is restricted to vacuum, hydrogen or inert atmospheres.

*Not an ANSI symbol

Thermocouple Conductor Gauge

Thermocouple conductors come in a variety of sizes. Depending on your application, the gauge selected will affect the thermocouple's performance.

The larger the gauge size, the more thermal mass the thermocouple will have with a corresponding decrease in response. The larger the gauge size the greater the stability and operating life. Conversely, a smaller gauge size will have a quicker response, but may not deliver the stability or operating life required.



Turn to **page 46** for recommended upper temperature limits for various thermocouple conductor gauges.

Application Guide

The Art of Temperature Sensing

Thermocouples

Continued

Industry specification have established the accuracy limits of industrial thermocouples. These limits define initial sensor performance at time of manufacture. Time, temperature and environment operating conditions may cause sensors to change during use. Also, keep in mind that overall system accuracy will depend on the instrument and other installation parameters.

Tolerances on Initial Values of EMF vs. Temperature – Ref. 24

Reference Junction 0°C (32°F)

| Calibration Type | Temperature Range °C (°F) | | Tolerances (whichever is greater) | | | |
|---|------------------------------|----------------|-----------------------------------|---------|--------------------|--------|
| | | | Standard °C (°F) | | Special °C (°F) | |
| Thermocouples ① ③ | | | | | | |
| B | 870 to 1700 | (1600 to 3100) | ±0.5% | ② | ±0.25% | ② |
| E | 0 to 870 | (32 to 1600) | ±1.7 or ±0.5% | ② | ±1.0 or ±0.4% | ② |
| J | 0 to 760 | (32 to 1400) | ±2.2 or ±0.75% | ② | ±1.1 or ±0.4% | ② |
| K or N | 0 to 1260 | (32 to 2300) | ±2.2 or ±0.75% | ② | ±1.1 or ±0.4% | ② |
| R or S | 0 to 1480 | (32 to 2700) | ±1.5 or ±0.25% | ② | ±0.6 or ±0.1% | ② |
| T | 0 to 370 | (32 to 700) | ±1.0 or ±0.75% | ② | ±0.5 or ±0.4% | ② |
| E ^④ | -200 to 0 | (-328 to 32) | ±1.7 or ±1% | ② | ⑤ | ② |
| K ^④ | -200 to 0 | (-328 to 32) | ±2.2 or ±2% | ② | ⑤ | ② |
| T ^④ | -200 to 0 | (-328 to 32) | ±1.0 or ±1.5% | ② | ⑤ | ② |
| Extension Wires ⑥ ⑦ | | | | | | |
| EX | 0 to 200 | (32 to 400) | ±1.7 | (±3.0) | ±1.0 | (±1.8) |
| JX | 0 to 200 | (32 to 400) | ±2.2 | (±4.0) | ±1.1 | (±2.0) |
| KX or NX | 0 to 200 | (32 to 400) | ±2.2 | (±4.0) | ±1.1 | (±2.0) |
| TX | 0 to 100 | (32 to 200) | ±1.0 | (±1.8) | ±0.5 | (±0.9) |
| Compensating Extension Wires ⑧ ⑨ | | | | | | |
| BX ^⑩ | 0 to 200 | (32 to 400) | ±4.2 | (±7.6) | * | * |
| CX | 0 to 260 | (32 to 500) | ±6.8 | (±12.2) | * | * |
| RX, SX | 0 to 200 | (32 to 400) | ±5.0 | (±9.0) | * | * |

- ① Tolerances in this table apply to new essentially homogeneous thermocouple wire, normally in the size range 0.25 to 3 mm (0.010 to 0.118 in.) in diameter (No. 30 to No. 8 AWG) and used at temperatures not exceeding the recommended limits on page 20 in Watlow's Temperature Sensing Solutions Catalog. If used at higher temperatures these tolerances may not apply.
- ② At a given temperature that is expressed in °C, the tolerance expressed in °F is 1.8 times larger than the tolerance expressed in °C. Note: Wherever applicable, percentage-based tolerances must be computed from temperatures that are expressed in °C.
- ③ **Caution:** Users should be aware that certain characteristics of thermocouple materials, including the EMF vs. temperature relationship may change with time in use; consequently, test results and performance obtained at time of manufacture may not necessarily apply throughout an extended period of use. Tolerances given above apply only to new wire as delivered to the user *and do not allow for changes in characteristics with use*. The magnitude of such changes will depend on such factors as wire size, temperature, time of exposure and environment. It should be further noted that due to possible changes in homogeneity, attempting to recalibrate *used* thermocouples is likely to yield irrelevant results, and is not recommended. However, it may be appropriate to compare used thermocouples *in-situ* with new or known good ones to ascertain their suitability for further service under the conditions of the comparison.
- ④ Thermocouples and thermocouple materials are normally supplied to meet the tolerances specified in the table for temperatures above 0°C. The same materials, however, may not fall within the tolerances given for temperatures below 0°C in the second section of the table. If materials are required to meet the tolerances stated for temperatures below 0°C the purchase order must so state. Selection of materials usually will be required.
- ⑤ Special tolerances for temperatures below 0°C are difficult to justify due to limited available information. However, the following values for Types E and T thermocouples are suggested as a guide for discussion between purchaser and supplier: Type E: -200 to 0°C ±1.0°C or ±0.5 percent (whichever is greater); Type T: -200 to 0°C ±0.5 or ±0.8 percent (whichever is greater).

Initial values of tolerance for Type J thermocouples at temperatures below 0°C and special tolerances for Type K thermocouples below 0°C are not given due to the characteristics of the materials.

- ⑥ Tolerances in the table represent the maximum error contribution allowable from new and essentially homogeneous thermocouple extension wire when exposed to the full temperature range given above. Extension grade materials are not intended for use outside the temperature range shown.
 - ⑦ Thermocouple extension wire makes a contribution to the total thermoelectric signal that is dependent upon the temperature difference between the extreme ends of the extension wire length. The actual magnitude of any error introduced into a measuring circuit by homogeneous and correctly connected extension wires is equal to the algebraic difference of the deviations at its two end temperatures, as determined for that extension wire pair.
 - ⑧ Tolerances in the table apply to new and essentially homogeneous thermocouple compensating extension wire when used at temperatures within the range given above.
 - ⑨ Thermocouple compensating extension wire makes a contribution to the total thermoelectric signal that is dependent upon the temperature difference between the extreme ends of the compensating extension wire length.
 - ⑩ Special compensating extension wires are not necessary with Type B over the limited temperature range 0 to 50°C (32 to 125°F), where the use of non-compensated (copper/copper) conductors introduces no significant error. For a somewhat larger temperature gradient of 0 to 100°C (32 to 210°F) across the extension portion of the circuit, the use of non-compensated (copper/copper) extension wires may result in small errors, the magnitude of which will not exceed the tolerance values given in the table above for measurements above 1000°C (1800°F). Proprietary alloy compensating extension wire is available for use over 0 to 200°C (32 to 400°F) temperature range.
- * Special tolerance grade compensating extension wires are not available.

Application Guide

The Art of Temperature Sensing

Thermocouples

Continued

Thermocouple Junction

All thermocouples have **Hot** and **Cold** junctions. Further, the **Hot** junction may be physically exposed or unexposed (protected).

The **Hot junction** is the junction subjected to the heat being measured. The **Cold**, or *reference junction*, is another junction in the thermocouple circuit, usually at, or compensated to, 0°C (32°F). **Cold** junctions are generally eliminated in the thermocouple circuit by using electrical or hardware compensating methods.

A thermocouple's thermoelectric voltage is generated between the **Hot** and **Cold** junctions, not where the two thermoelements are physically joined. The Seebeck effect takes place in the temperature gradients between the isothermal portion at the **Hot** junction end and the isothermal portion at the **Cold** junction end.

The thermocouple's physical construction may have its **Hot** junction exposed or unexposed. An *exposed* junction has its bare thermoelements in contact with the substance being measured. An unexposed junction has a shielding to protect it from hostile environments. Unexposed junctions are commonly found in thermocouples made from mineral insulated, metal-sheathed cable.

Another aspect of the *unexposed* thermocouple junction is whether it's grounded or ungrounded. In the grounded construction, the thermocouple junction is electrically connected to the sheath or protecting tube material. An ungrounded construction has its junction electrically isolated from its sheath or protecting tube.

Each style has advantages and disadvantages depending on your particular application and electrical considerations.

Thermocouple Selection

Thermocouple specifications are selected to meet the conditions of the application. Only general recommendations on wire gauge size and type can be given. Some of the considerations involved are:

- Length of service
- Application temperature
- Atmosphere
- Desired response time
- Accuracy

The temperature ranges of the commonly used thermocouple types are given in the (Initial Calibration Tolerances Table on [pages 61 - 62.](#)) Smaller wire gauges provide faster

response at the expense of service life at elevated temperatures. Larger gauge sizes provide longer service life at the expense of response. As a general rule, it is advisable to protect thermocouple elements with a suitable protection method.

Note: Temperatures discussed are in relation to table #7, page 15, of ANSI MC96.1, August, 1982.

When ordering thermocouple wire or elements, be certain that the Type (K, J, E, etc.) corresponds to that of the instrument with which it will be used.

Application Guide

The Art of Temperature Sensing

Wire Insulations

Due to a temperature sensor's electrical nature it's important to provide conductors with sufficient insulation to avoid shunts or short circuits. To accomplish this, thermocouple wire, thermocouple extension wire and RTD lead wire come in a variety of insulations and configurations. The two primary constructions are:

- "Soft" wire and cable
- Mineral insulated, metal-sheathed cable

Wire is generally understood to mean a one-or two-conductor soft insulated construction. Cable can be a soft construction with more than two conductors, excluding drain wires, or conductors encased in a metal sheath.

Soft Wire and Cable

Soft wire and cable use one or more flexible dielectric materials to insulate each conductor and produce constructions by:

- Duplexing with an additional insulation covering
- Duplex extruding (as with lamp cord)
- Twisted to keep the conductors together and add resistance to electromagnetic interference

Many different dielectric materials are used as insulation, from lacquers to elastomer plastics to high temperature



See the Watlow Temperature Sensing Solutions catalog for information on soft wire constructions, insulations,

fibers. Each material or combination of materials is used to achieve the objective of preventing shunts and short circuits for a given application. Constructions are made to withstand ambient operating temperature and electrical noise conditions; with physical properties to withstand moisture, chemicals and abrasion.

In addition to dielectric insulations, soft wire can be supplied with a number of metallic overbraids to increase abrasion resistance or provide additional electrical shielding.

physical properties and temperature ratings; information on metallic overbraids; and information on UL® listed PLTC constructions.

Mineral Insulated, Metal-Sheathed Cable

Commonly referred to as MI cable, this construction is well suited for demanding applications where elevated temperatures or hostile environments make soft insulated wire unsuitable.

MI cable is most often made by placing crushable mineral oxide insulators around conductors and inserting them into a metal tube. This tube is then drawn down to the desired outside diameter and conductor gauge.



See Watlow Temperature Sensing Solutions catalog for:

- MI cable calibrations
- MI cable sheath materials
- MI cable insulations
- Grounded and ungrounded junction MI cable sensors
- Fabricating sensors with MI cable

Some materials that do not lend themselves to being drawn, such as molybdenum, are used in undrawn or "uncompacted" constructions.

MI cable construction provides a protective sheath around the conductors, with the added advantage of a compacted insulation that improves thermal conductivity from the sheath to the conductors. Sheaths can be made from a wide variety of malleable metals, so matching sheath material to temperature range and chemical environment is relatively easy.

Conductors are insulated from the sheath using a variety of mineral oxide dielectric materials. The most common material is magnesium oxide (MgO). Insulation is selected according to its dielectric strength for the intended operating temperature and matched up with a sheath material selected to withstand the same temperature.

MI cable has the advantage of being fabricated into a complete sensor assembly, combining sensing element and protective sheath in one.

UL® is a registered trademark of Underwriter's Laboratories, Inc.

Application Guide

The Art of Temperature Sensing

Rules of Good Thermocouple Practice

With proper installation and normal conditions, thermocouples can be depended upon to give trouble free service and long life. Occasionally difficulties may be encountered resulting from improper application or operation. The information presented here serves as a short guide to help thermocouple users obtain the accuracy and economy for which the thermocouple alloys are produced.

1. Protect Thermocouples in Service

Evaporation, diffusion, oxidation, corrosion and contamination induce EMF drift due to their effect on the composition of thermocouple alloys. In as much as these environmental factors are destructive to all common thermocouple materials, it is essential that proper protection be provided whenever adverse conditions are encountered. In many applications, this requirement can be met by the use of sheathed unit construction. If bare wire thermocouples are used, the thermoelements must be properly installed in suitable protection tubes. When the interiors of such tubes are clean and free of sulfur-bearing oils, refractories, etc.—and when they are of the proper diameter-to-length ratios to permit adequate ventilation inside, they serve admirably in overcoming the harmful effects of corrosive atmosphere.

2. Use Largest Practical Wire Size

It is generally true that heavy gauge thermocouples are more stable at high temperatures than their finer gauge counterparts. In many applications, however, a heavy gauge thermocouple will not satisfy requirements for flexibility, rapid response, equipment geometry and the like. A compromise must then be struck between long-term stability of heavy sizes and

greater versatility of smaller thermocouples. Where high temperature stability is a substantial consideration, use the largest practical wire size consistent with the other requirements of the job.

3. Install Thermocouple in Proper Location

The location selected for installation of the thermocouple should insure that the temperatures being measured are representative of the equipment or medium. Direct flame impingement on the thermocouple, for example, does not provide a representative temperature.

4. Provide for Sufficient Immersion Depth

Since heat conducted away from the “hot” junction causes the thermocouple to indicate a lower temperature, provide for sufficient depth of immersion of the thermocouple into the medium being measured to minimize heat transfer along the protection tube. As a general rule, a minimum immersion of 10 times the outside diameter of the protection tube should be used.

5. Avoid Changing Depth of Immersion

Under certain conditions, inhomogeneities may gradually develop in a pair of thermocouple wires due to oxidation, corrosion, evaporation, contamination or metallurgical changes. A change in depth of immersion, which shifts such inhomogeneous wire into a steep temperature gradient zone, can alter the thermocouple output and produce erroneous readings. Therefore, avoid changing the depth of immersion of a thermocouple after it has been in service.

6. Recognize Effect of Heating Cycles

For maximum accuracy, a thermocouple should be used to control a single temperature, or successively higher temperatures only. For various reasons, however, this procedure cannot always be followed. In many installations, thermocouples continually traverse a broad range of temperatures, with wholly adequate

results. Errors which arise out of cyclic heating are analogous to those generated by changes in immersion, and may range from two or three degrees Fahrenheit for thermocouples in good condition, to many degrees for badly corroded couples. Thus the type of heating cycle and condition of the thermocouple mutually affect the accuracy obtainable in a specific location. Where cyclic heating cannot be avoided, use top condition thermocouples for maximum accuracy.

7. Establish Preventive Maintenance Program

Thermocouples, protection tubes and extension wire circuits should be checked regularly. Experience largely determines the frequency of inspection, but once a month is usually sufficient.

Check out extension wire circuit by making certain that it meets the established external resistance requirement.

Damaged or burned out protection tubes should be replaced to prevent damage to the thermocouple.

Thermocouples should be checked in place, if possible. If it is necessary to remove the thermocouple, it should be reinserted to the same depth or deeper to avoid errors arising from placing an inhomogeneous segment of wire in a steep temperature gradient.

Application Guide

The Art of Temperature Sensing

Trouble-Shooting Thermocouple Installations with Erroneous Readings

When a thermocouple installation is suspected of giving erroneous readings, the following check steps may be taken to isolate the source of trouble.

1. Check Circuit—The first step is to check the polarity of the thermocouple circuit and all connection contacts. The positive thermocouple wire should be properly connected to positive extension wire which, in turn, should be securely connected to the positive side of the meter. The negative thermocouple and extension wire should be properly connected to the negative side of the meter. A brief check at these points will often save a service call and delays in production. Wires can generally be identified by color coding or by verifying magnetism.

2. Check Instrument—If the circuit checks out all right, the next step is to check the control, meter or recording instrument. Verify instrument has been set for the thermocouple type being used. If checked as to room temperature setting (cold junction compensation). This is done by removing the extension wires, placing a jumper across terminals from the meter connection and observing the meter reading. It should coincide with the room temperature.

If further diagnosis is required, should be checked by comparing its readings against those obtained with a test thermocouple of known accuracy connected to a portable meter also of known accuracy. In making such a check, it is important that the test thermocouple be inserted

along side the working thermocouple with the hot junction as close together as possible. It is also essential that the temperature of both the working and the test meter be the same.

If, under these conditions, the test meter reading agrees with that indicated by the working meter, the source of trouble is not in the pyrometry circuit but is, perhaps, in the furnace itself. If the test meter reading does not agree with the working meter reading, the following checks should be made to isolate the trouble.

3. Check Thermocouple—Severely oxidized or corroded thermocouples are always suspect. Changes in wire composition can result from corrosion and contamination by extraneous elements. Impurities such as sulfur and iron plus other constituents picked up from furnace refractories, oxide scale, brazing alloys and fluxes constitute potential sources of drift away from initial calibration.

To check the working thermocouple, hook it up to the test meter of known accuracy and observe the reading. If the reading is the same as that previously obtained from the test thermocouple of known accuracy, then the working thermocouple is not the cause of trouble.

4. Test Meter and Extension Wires

To check the working meter and extension wires, connect the extension wires to the test thermocouple of known accuracy and observe the temperature reading. If the reading is not the same as that obtained with the test meter, the trouble is either in the extension wires or in the working meter.

The above checks are intended only as elementary guides in trying to pinpoint the possible cause or causes of faulty temperature control. If the cause of erroneous readings can definitely be localized in the thermocouple itself, it should be removed and inspected. A visual inspection, plus a few tests which can readily be made with only hand instruments, will often reveal the condition which caused the thermocouple wires to go off calibration. Severely oxidized or corroded thermocouples should be replaced. It is usually more economical to replace a suspected thermocouple than to risk loss of costly time, product or equipment through inadequate temperature control.

Ref. 25

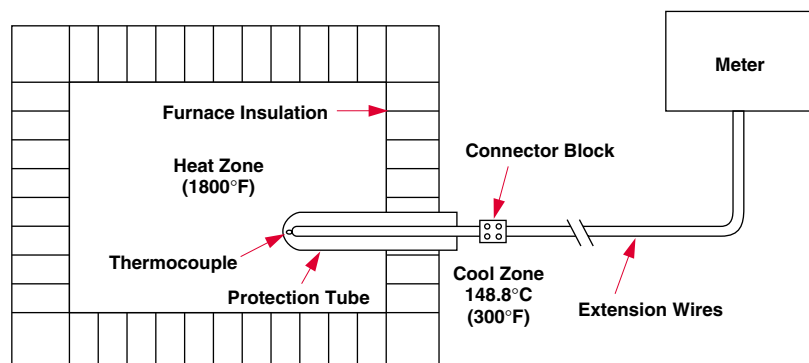

Application Guide

The Art of Temperature Sensing

Metallurgical Factors

Ref. 26

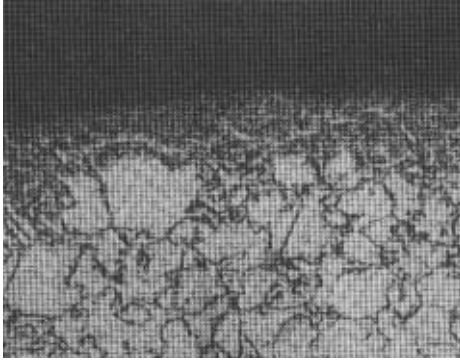

Inter-granular attack due to selective oxidation in 8-gauge wire. (Unetched, X100)

Premature thermocouple failure is most frequently a result of contamination or corrosion due to uncontrolled furnace atmosphere, unclean or leaking protection tubes, or some other factor related to improper installation or operation. Damaging conditions can usually be detected and corrected through a program of frequent and systematic ther-

mocouple inspections before complete thermocouple failure occurs.

One or the other of the following conditions is usually found on examination of Chromel-Alumel® thermocouples experiencing early failure.

1. Selective Oxidation—sometimes referred to as “green rot”—is typified by a greenish surface or subsurface scale that develops in nickel-chromium alloys, when subjected to a marginally oxidizing environment at high temperature.

The formation of a thin nickel film will give the non-magnetic KP magnetic properties.

In applications where an abundant supply of oxygen is available, or where there is none at all, green rot does not occur. Reducing atmospheres such as pure dry hydrogen, will not adversely affect nickel thermocouple alloys.

When green rot is apparent, check for the following possibilities:

- Protecting tubes having too small an inside diameter, or too great a length-diameter ratio, which prohibit a reasonably free air circulation between the insulated (ceramic)

thermocouple element and the tube wall.

- Leaks in protecting tubes with refractory metal (titanium, columbium, tantalum) wires inside and sealed at the “cold end.” The purpose of the refractory metal wire is to “sop up” all available oxygen creating an oxygen free atmosphere. The atmosphere will become partially oxidizing when the refractory metal wire cannot absorb all the oxygen setting the stage for green rot.
- Improperly degreased protecting tube interior. Residues of greases and oils will decompose and release sulfur, a deadly enemy of nickel alloys.
- Leaky protecting tubes in reducing (hydrogen for example) or carbonaceous gas containing furnaces, where furnace atmospheres can penetrate the tube and will cause partially oxidizing conditions within the leaky tube.
- Presence of zinc (galvanized tubes) or zinc-containing alloys, such as brass. Vapors from these metals will accelerate deterioration of nickel thermocouple alloys.

Ref. 27

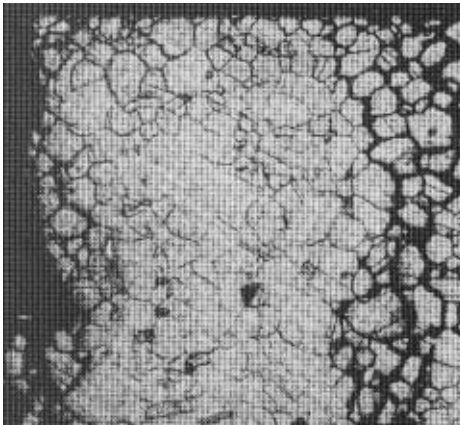

Transverse inter-granular cracks due to sulfur attack in 8-gauge wire. (Electrolytic etch, X35)

Alumel® is a registered trademark of Hoskins Manufacturing Company.

2. Sulfur Attack—Sulfur is particularly harmful to high nickel alloys including KN. In heat-treating operations, sulfur may come from various sources such as furnace atmospheres, oil, mortar, cements and asbestos. In Type K thermocouples, sulfur attack often reveals itself in breakage of the KN wire. Thus, when normally ductile KN wire appears to have become brittle in service, that is, if surface cracks appear when it is bent with the fingers, it is likely that sulfur corrosion has occurred. In case of doubt, the presence of sulfur can be determined positively by performing any one of several chemical tests.

A simple test for sulfur in a suspected material is to immerse a sample of the material in a solution of 20 percent

hydrochloric acid containing a few pieces of metallic zinc. If sulfur is present in the sample, it can be identified by the characteristic hydrogen sulfide odor of rotten eggs that will evolve. Also, moistened lead acetate paper held over the top of the test solution will turn brown or black if sulfur is present in the sample.

Where there is evidence of sulfur attack in the thermocouple, it should be replaced, and an attempt made to eliminate the source of sulfur. If elimination of the source is not feasible, then the thermocouple should be completely isolated from the contaminating material. The possibility of a leak in an existing protection tube should not be overlooked.

Application Guide

The Art of Temperature Sensing

Properties of Nickel Thermocouple Alloys

Causes of Aging (Drift)

The term “aging” refers to a positive EMF shift (more output) of nickel thermocouple alloys due to a temperature gradient along the thermocouple elements. Although the temperatures at which aging occurs are not absolutely defined, the temperature range of 370° to 540°C (700° to 1000°F) is generally used as the limit for the aging range. Several factors that will influence the amount of EMF shift are:

- Temperature being measured, previous thermal history of the thermocouple
- Time and duration at aging temperature
- Specific thermocouple composition
- Amount of the thermocouple subjected to the aging temperature

The thermocouple user must be aware that the amount of aging effect is dependent upon the specific application and temperature gradient in that application.

When aging effects are believed to have occurred, an observation of thermocouple application should be made. First, the operating temperature of the thermocouple should be checked. If the entire thermocouple has never been subjected to aging

temperature, errors due to aging should not occur. When temperature measurements are made in the aging range and undesirable errors due to aging occur, in certain applications a pre-aged thermocouple may be used. (Not available in compacted metal-sheath assemblies.) A pre-aged thermocouple is one of specially selected chemical composition and calibration values which is heat treated to minimize error due to aging effects. However, if pre-aged wire is subjected to temperature above the aging range, the effect of the heat treatment process is removed. For measurements above the aging range, the length of thermocouple in the gradient of aging temperatures needs to be minimized to keep aging effects small.

The effects of aging are reversible. To remove the aging effects, heat the entire thermocouple to above 870°C (1600°F) for a minimum of five minutes and then rapidly cool to below the aging temperatures. This heat treating process should restore original wire calibration.

Application Guide

The Art of Temperature Sensing

Recommended Upper Temperature Limits for Protected Thermoelements

Upper Temperature Limits for Various Wire Sizes (B & S Gauge), °F (°C)—Ref. 28

| Thermoelement | No. 8 Gauge, 3.25 mm (0.128 in.) | No. 14 Gauge, 1.63 mm (0.064 in.) | No. 20 Gauge, 0.81 mm (0.032 in.) | No. 24 Gauge, 0.51 mm (0.020 in.) | No. 28 Gauge, 0.33 mm (0.013 in.) | No. 30 Gauge, 0.25 mm (0.010 in.) |
|----------------|--|---|---|---|---|---|
| JP | 760°C (1400°F) | 590°C (1100°F) | 480°C (900°F) | 370°C (700°F) | 370°C (700°F) | 320°C (600°F) |
| JN, TN, EN | 870°C (1600°F) | 650°C (1200°F) | 540°C (1000°F) | 430°C (800°F) | 430°C (800°F) | 430°C (800°F) |
| TP | — — | 370°C (700°F) | 260°C (500°F) | 205°C (400°F) | 205°C (400°F) | 150°C (300°F) |
| KP, EP, KN | 1260°C (2300°F) | 1090°C (2000°F) | 980°C (1800°F) | 870°C (1600°F) | 870°C (1600°F) | 760°C (1400°F) |
| RP, SP, RN, SN | — | — | — | 1480°C (2700°F) | — | — |
| BP, BN | — | — | — | 1705°C (3100°F) | — | — |
| NP, NN | 1260°C (2300°F) | 1090°C (2000°F) | 980°C (1800°F) | 870°C (1600°F) | 870°C (1600°F) | 760°C (1400°F) |

Note: This table gives the recommended upper temperature limits for the various thermoelements and wire sizes. These limits apply to protected thermoelements, that is, thermoelements in conventional closed-end protecting tubes. They do not apply to sheathed thermoelements having compacted mineral oxide insulation. In any general recommendation of thermoelement temperature limits, it is not practical to take into account special cases. In actual operation, there may be instances where the temperature limits recommended can be exceeded. Likewise, there may be applications where satisfactory life will not be obtained at the recommended temperature limits. However, in general, the temperature limits listed are such as to provide satisfactory thermoelement life when the wires are operated continuously at these temperatures.

Application Guide

The Art of Temperature Sensing

Thermocouple Response Time

Since you're actually interested in the temperature of the surrounding medium, accuracy depends on the ability of the sensor to conduct heat from its outer sheath to the element wire.

Several factors come into play. The most commonly noted is "time

constant" (thermal response time). Time constant, or thermal response time, is an expression of how quickly a sensor responds to temperature changes. As expressed here, time response is defined as how long it takes a sensor to reach 63.2 percent of a step temperature change (see Ref. 30).

Response is a function of the mass of the sensor and its efficiency in transferring heat from its outer surfaces to the sensing element. A rapid time response is essential for accuracy in a system with sharp temperature changes. Time response varies with the probe's physical size and design. The response times indicated are representative of standard industrial probes.

Ref. 29

| Sheath Diameter | Average Response Time Still Water (seconds)* | |
|-----------------|--|---------------------|
| | Grounded Junction | Ungrounded Junction |
| 0.010 in. | <0.02 | <0.02 |
| 0.020 in. | <0.02 | 0.03 |
| 0.032 in. | 0.02 | 0.07 |
| 0.040 in. | 0.04 | 0.13 |
| 0.063 in. | 0.22 | 0.40 |
| 0.090 in. | 0.33 | 0.68 |
| 0.125 in. | 0.50 | 1.10 |
| 0.188 in. | 1.00 | 2.30 |
| 0.250 in. | 2.20 | 4.10 |
| 0.313 in. | 5.00 | 7.00 |
| 0.375 in. | 8.00 | 11.00 |
| 0.500 in. | 15.00 | 20.00 |
| 0.5 mm | <0.02 | 0.03 |
| 1.0 mm | 0.04 | 0.13 |
| 1.5 mm | <0.15 | 0.35 |
| 2.0 mm | 0.25 | 0.55 |
| 3.0 mm | 0.40 | 0.90 |
| 4.5 mm | 0.95 | 2.00 |
| 6.0 mm | 2.00 | 3.50 |
| 8.0 mm | 5.00 | 7.00 |

*Readings are to 63 percent of measured temperatures.

Ref. 30

Time Constant (Thermal Response Time)

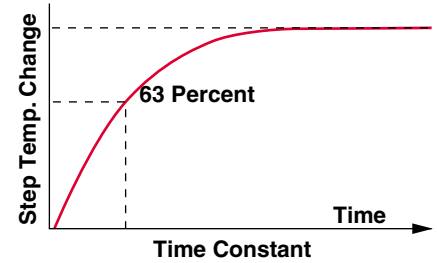

Application Guide

The Art of Temperature Sensing

Thermowells and Protecting Tubes

Using thermowells and protecting tubes will isolate a sensor from hostile environments that could adversely affect its operation or life.

Thermowells are machined from solid bar stock and come in a wide variety of metals and alloys.

Protecting tubes are made up from parts, either metallic or non-metallic materials, generally ceramics.



See Watlow Temperature Sensing Solutions, Temperature Sensors, Wire and Cable catalog for:

- **Thermowell Material Selection Guide**
- **Ceramic and Silicon-Carbide Protecting Tube Application Data**
- **Typical Physical Data for Protecting Tubes**
- **Physical Properties of Hexoloy® Materials— Technical Data**

Material Selection

In selecting a thermowell or protecting tube, the first thing to do is determine the nature of the environment and what material will best resist its destructive effects. To select the appropriate material, see Watlow's Temperature Sensing Solutions Catalog, pages 127-131, for **Thermowell Manufacturing Standards and Material Selection Guide**.

The guide will help you determine what material will best meet your protection requirements. Please note that it's not just the corrosive agent, but also its temperature. Temperature can have a

significant effect on how a material will hold up in actual conditions.

Measuring a substance that's flowing is another consideration. In this case, you need to determine the fluid's viscosity at the process operating temperature and combine that factor with its flow rate to determine the amount of lateral (shear) force it will exert on the face of the thermowell or protecting tube. Once the total shear force is figured, you must then be sure the size, shape and material will hold up. Don't forget to include the effects of erosion if the fluid has abrasive particulate material.

Teflon® Coatings

If the thermal mass of a thermowell or protecting tube slows response to an unacceptable level, Teflon® coatings may provide a solution. Possessing a high resistance to many corrosive agents, Teflon® coating can protect a

low-mass probe that would otherwise be damaged in a hostile environment. Such applications include electroplating and anodizing baths, and many common acids like sulfuric, hydrochloric, nitric and chromic.

Hexoloy® is a registered trademark of Carborundum Company.

Teflon® is a registered trademark of E.I. du Pont de Nemours & Company.

Application Guide

The Art of Temperature Sensing

Resistance Temperature Detectors—RTDs

RTDs are temperature sensors utilizing metals known and predictable change in electrical resistance based on a rise or fall in temperature. The sensing element is a deposited film or coil of wire, usually platinum, nickel, copper, or nickel-iron.

RTDs generally have a positive temperature coefficient. RTDs are powered devices. The instrument receiving their “signal” reads temperature as the change in voltage. Looked at another way, as temperature changes, so does the sensor’s resistance.

Because these are resistance devices, their operation generates heat in addition to the heat they’re measuring. When specifying the use of an RTD, its mass and self-generated heat must

be taken into account. Ideally the substance being measured will have enough mass and thermal conductivity so as to make the RTD’s self-generated heat a negligible factor.

RTD Interchangeability

Interchangeability is a commonly cited factor of RTD accuracy. It tells how closely the sensing element of an RTD follows its nominal resistance/temperature curve, and the maximum variation that should exist in the readings of identical sensors, mounted side-by-side under identical conditions.

Interchangeability consists of both a tolerance at one reference temperature, usually 0°C, and a tolerance on the slope, or Temperature Coefficient

of Resistance (TCR). Even a slight deviation in the TCR will cause a significant error to result at elevated

temperatures. Thus, it’s important for the user to specify the TCR when ordering RTD probes.

Ref. 31

| Element Type | Temperature Range | Base Resistance | TCR($\Omega/\Omega/^\circ\text{C}$) |
|---------------|--------------------------------|---------------------|---------------------------------------|
| *Platinum DIN | -200 to 650°C (-330 to 1200°F) | 100 Ω at 0°C | 0.00385 |
| Copper | -100 to 260°C (-150 to 500°F) | 10 Ω at 25°C | 0.00427 |
| Nickel | -100 to 205°C (-150 to 400°F) | 120 Ω at 0°C | 0.00672 |

*Thin film element -50 to 550°C (-58 to 1020°F).

RTD Tolerance Class Definitions

DIN/IEC class A: $\pm(0.15 + 0.002 |t|)^\circ\text{C}$
 DIN/IEC class B: $\pm(0.30 + 0.005 |t|)^\circ\text{C}$

Where **t** is the actual temperature, in °C, of the platinum elements.

Table of Tolerance Values – Ref. 32

| Temperature °C (°F) | Resistance Value Ω | Tolerance DIN-IEC-751 | |
|------------------------|--------------------------|-----------------------|-------------------|
| | | Class A °C (Ω) | Class B °C (Ω) |
| -200 (-328) | 18.52 | ±0.55 (±0.24) | ±1.3 (±0.56) |
| -100 (-148) | 60.26 | ±0.35 (±0.14) | ±0.8 (±0.32) |
| 0 (32) | 100.00 | ±0.15 (±0.06) | ±0.3 (±0.12) |
| 100 (212) | 138.51 | ±0.35 (±0.13) | ±0.8 (±0.30) |
| 200 (392) | 175.86 | ±0.55 (±0.20) | ±1.3 (±0.48) |
| 300 (572) | 212.05 | ±0.75 (±0.27) | ±1.8 (±0.64) |
| 400 (752) | 247.09 | ±0.95 (±0.33) | ±2.3 (±0.79) |
| 500 (932) | 280.98 | ±1.15 (±0.38) | ±2.8 (±0.93) |
| 600 (1112) | 313.71 | ±1.35 (±0.43) | ±3.3 (±1.06) |
| 650 (1202) | 329.64 | ±1.45 (±0.46) | ±3.6 (±1.13) |

Application Guide

The Art of Temperature Sensing

Resistance Temperature Detectors—RTDs

Continued

Effects of Lead Wires on RTD Accuracy

The majority of RTD applications throughout industry today standardize on the three-lead wire systems.

Frequently the question arises—what is the difference in two-, three- or four-wire RTDs and how does the system operate?

The key issue is accuracy. Most manufacturers will specify accuracy as 0.1 percent or a similar figure. This number only refers to how tightly the element (resistor) is calibrated at one temperature and does not reflect the total sensor accuracy after lead wire has been added to the resistance element. Understanding how the bridge circuit operates should answer these questions and further emphasize the value of three- and four-wire systems, when accuracy is important to the user.

Because an RTD is a resistance type sensor, any resistance in the extension wire between the resistive element and control instrument will add to the readings. Furthermore, this added resistance is not constant, since the conductor in lead wires changes resistance with changing ambient temperature. Fortunately, errors may be nearly canceled by using a three- or four-wire system.

Two-Wire Circuit

Ref. 33

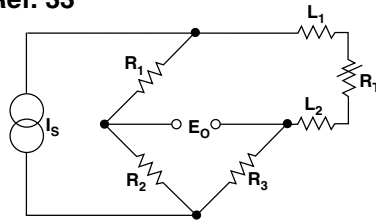

Reference 33 shows a two-wire RTD connected to a typical Wheatstone bridge circuit. I_s is the supply current; E_o is the output voltage; R_1 , R_2 , R_3 are fixed resistors; and R_T is the RTD. In this circuit, lead resistances L_1 and L_2 add directly to R_T .

Three-Wire Circuit

Ref. 34

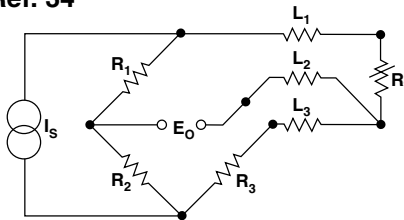

In the three wire circuit shown in Reference 34, the identical measuring current flows through L_1 and L_3 , can-

celing their resistance, since they're in two separate arms of the bridge. L_2 , connected to E_o , is used only as a potential lead; no current flows through it when the bridge is balanced. This method of lead wire compensation depends on close matching of the resistance in L_1 and L_3 and high impedance at E_o , since any current flow in L_2 will cause errors. The two common leads, L_2 and L_3 , are normally the same color for easy identification.

Four-Wire Circuit

Ref. 35

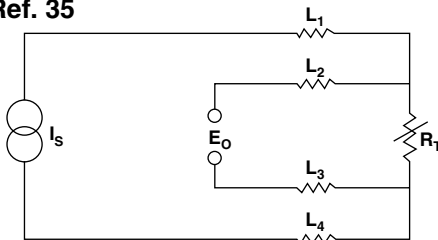

Four-wire circuits offer the ultimate performance over extreme distances, or where small errors such as contact

resistance become significant. Although many laboratory systems employ resistive networks for four-wire compensation, the most common industrial circuit drives a constant current through two leads, and measures current drop across the remaining two (see Reference 35). Assuming that input impedance prevents current flow in L_2 and L_3 , the only significant source of error is variation in the measuring current.

Adding Extra Leads

Ref. 36

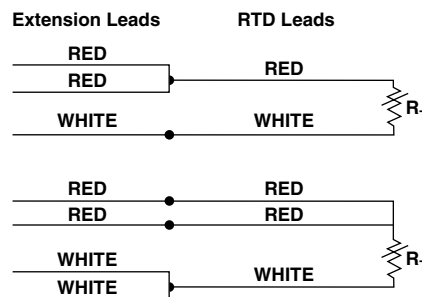

If necessary, you can connect a two wire RTD to a three-wire circuit, or a three-wire RTD to a four-wire circuit. Just attach the extra extension wires to the ends of the RTD leads, as shown in Reference 36. As long as these connections are close to the sensing element, as in a connection head, errors should be negligible.

Application Guide

The Art of Temperature Sensing

Resistance Temperature Detectors—RTDs

Continued

RTD Resistance Comparisons

Since the amount of electrical resistance is a function of a material's temperature, resistance of RTDs can theoretically be made from any metallic element or alloy. Most often they're made from copper, nickel, nickeliron or platinum. The non-linear response of nickel and limited temperature range of copper makes platinum the most commonly used resistance material.

The most notable advantage of platinum RTDs is their precise and predictable response to changes in temperature. Platinum is the most widely used RTD in military, aerospace and nuclear and many other applications requiring a high degree of precision. Platinum also has the advantage of being relatively indifferent to its environment,

corrosion resistant and not easily oxidized. It can be drawn to a fine wire; uniformly deposited in films and can withstand extreme temperatures with its high melting point of approximately 2040°C (3700°F).

All resistance wire RTDs have a positive temperature coefficient—their resistance increases as temperature increases.

Ref. 37

| Element Metal | Temperature Range | Benefits | Base Resistance | TCR ($\Omega/\Omega/^\circ\text{C}$) |
|---------------|--------------------------------|--------------------------------|---------------------|--|
| Platinum | -260 to 850°C (-436 to 1562°F) | Best stability, good linearity | 100 Ω at 0°C | 0.00385 (DIN-IEC-60751), |
| Copper | -100 to 260°C (-148 to 500°F) | Best linearity | 10 Ω at 25°C | 0.00427 |
| Nickel | -100 to 260°C (-148 to 500°F) | Low cost, High sensitivity | 120 Ω at 0°C | 0.00672 |

RTD Lead Wire Compensation

Because an RTD is a resistance device, any resistance in the lead wires between sensor and instrument will add resistance to the circuit and alter the readings. Compensating for this extra resistance with adjustments at the instrument may be possible. However, variations in ambient temperature alter copper lead wire resistance, so this only works when lead wires are held at a constant temperature.

The table below contains resistance values for common copper lead wire gauges. To approximate the error in an uncompensated sensor circuit, multiply the length (in feet) of both extension leads by the approximate value in the table. Then divide it by the sensitivity of the RTD element to obtain an error value in °C. For example, assume a 100 ohm platinum element with 0.00385 TCR and 22 B & S

Gauge leads, 150 feet long:

$$\text{Total resistance} = 300 \text{ ft} \times 0.0165 \text{ ohm/ft} = 4.95 \text{ ohm}$$

$$\text{Approx. error} = 4.95 \text{ ohms} / (0.385 \text{ ohm}/^\circ\text{C}) = 12.9^\circ\text{C}$$

Ref. 38

| Lead Wire B & S Gauge | Ohms/ft at 25°C | Base Resistance (Ohms) | TCR | Sensitivity (Avg. Ohm/°C 0 to 100°C) |
|-----------------------|-----------------|------------------------|----------|--------------------------------------|
| 16 | 0.0041 | 100 | 0.003850 | 0.3850 |
| 18 | 0.0065 | | | |
| 20 | 0.0103 | | | |
| 22 | 0.0165 | 1000 | 0.003850 | 3.8500 |
| 24 | 0.0262 | | | |
| 26 | 0.0418 | | | |
| 28 | 0.0666 | | | |
| 30 | 0.1058 | | | |

Depending on the length of run, lead wire error can be significant. Particularly so if the gauge is small, or connected to a low sensitivity element. Using a three-wire circuit will reduce errors in most applications to a negligible level.



Turn to **pages 63-72** for Resistance vs. Temperature tables.

Turn to **page 61** for RTD Initial Calibration Tolerances.

Application Guide

The Art of Temperature Sensing

Resistance Temperature Detectors—RTDs

Continued

Thermistors

Thermistors are semiconductor devices made from oxides of metals and other ceramics. As with almost all semiconductors, heat is the primary cause of failure. While this appears a little contradictory—using a semiconductor for measuring temperature—thermistors do have properties that make them very advantageous.

In deciding to use a thermistor, it's important to be sure the application is within its temperature limits. Inside their application range, thermistors exhibit a great change in resistance for a relatively small change in temperature.

Thermistors have the advantage over RTDs of being available in both positive and negative temperature coefficients; although positive temperature coefficients are less common.

A drawback with thermistors is they can fail in a closed mode. This could create problems if a failure produces a resistance value similar to a temper-

ature reading. Sufficient precautions should be taken into account and safeguards, like thermal fuses, designed into the sensor.

Additionally, thermistors do not have any established resistance vs. temperature standards comparable to the DIN-IEC-60751 standards for 100 ohm platinum wire RTDs. While different semiconductor manufacturers producing thermistors strive to have a similar resistance at 25°C (77°F), their curves can differ.



Turn to pages 63-69 for Thermistor Resistance vs. Temperature charts.

Application Hints

Where should my sensor be placed?

Placement of the sensor in relationship to the work load and heat source can compensate for various types of energy demands from the work load. Sensor placement can limit the effects of thermal lags in the heat transfer process. The controller can only respond to the temperature changes it “sees” through feedback from the sensor location. Thus, sensor placement will influence the ability of the controller to regulate the temperature about a desired set point.

Be aware that sensor placement cannot compensate for inefficiencies in the system caused by long delays in thermal transfer. Realize also that inside most thermal systems, temperature will vary from point-to-point.

Ref. 39 Sensor in a Static System

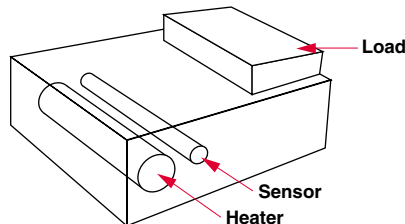

We call a system “static” when there is slow thermal response from the heat source, slow thermal transfer and minimal changes in the work load. When

the system is static, placing the sensor closer to the heat source will keep the heat fairly constant throughout the process. In this type of system, the distance between the heat source and the sensor is small (minimal thermal lag); therefore, the heat source will cycle frequently, reducing the potential for overshoot and undershoot at the work load. With the sensor placed at or near the heat source, it can quickly sense temperature changes, thus maintaining tight control.

Ref. 40 Sensor in a Dynamic System

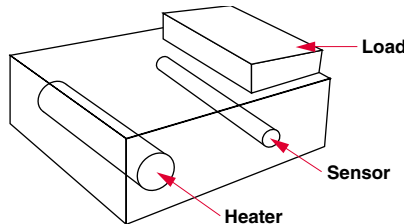

We call a system “dynamic” when there is rapid thermal response from the heat source, rapid thermal transfer and frequent changes in the work load. When the system is dynamic, placing the sensor closer to the work load will enable the sensor to “see” the load temperature change faster, and allow

the controller to take the appropriate output action more quickly. However, in this type of system, the distance between the heat source and the sensor is notable, causing thermal lag or delay. Therefore, the heat source cycles will be longer, causing a wider swing between the maximum (overshoot) and minimum (undershoot) temperatures at the work load.

We recommend that the electronic controller selected for this situation include the PID features (anticipation and offset ability) to compensate for these conditions. With the sensor at or near the work load, it can quickly sense temperature rises and falls.

Ref. 41 Sensor in a Combination Static/ Dynamic System

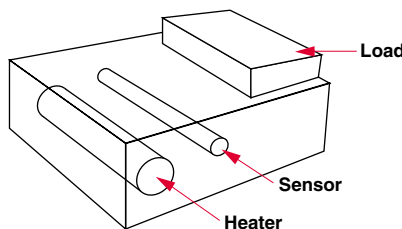

When the heat demand fluctuates and creates a system between static and dynamic, place the sensor halfway between the heat source and work load to divide the heat transfer lag times equally. Because the system can produce some overshoot and/or undershoot, we recommend that the electronic controller selected for this situation include the PID features (anticipation and offset ability) to compensate for these conditions. This sensor location is most practical in the majority of thermal systems.

Application Guide

Temperature Sensors

Non-Contact Temperature Sensor Basics

Many industrial applications require temperature measurement. A temperature value can be obtained either by making physical contact with the object or medium (see Contact Temperature Sensor Basics, [page 37](#)), or by applying a non-contact temperature sensor (infrared). An infrared temperature sensor intercepts heat energy emitted by an object and relates it to the product's known temperature. An infrared temperature sensor offers many advantages and can be applied where contact temperature sensing cannot be used. Some of these include:

- Can be mounted away from heat sources that could affect readings.
- Can sense the temperature of a moving object.
- The sensor will not heatsink, contaminate or deface the product.
- The sensor doesn't require slip rings.
- Can be isolated from contaminated or explosive environments by viewing through a window.

Additional benefits include:

- **Quality:** Quality of the finished product in many processes is directly related to the heating of the material. In many applications the heater, mold or platen temperature is controlled, not the temperature of the product. Monitoring product temperature insures a more consistent, repeatable and higher quality product is produced.
- **Increased productivity:** Applications where a material is processed based on period of time can hinder productivity. Applications where a material is placed into an oven or chamber and processed for a given amount of



time or until an operator indexes the process to the next stage can be time killers. Processing time can vary due to differences in starting temperature, humidity and other factors. Without any method of monitoring the product, an estimate of time or visual inspection is used. By using an infrared sensor, the product can be indexed when it has reached its desired temperature. The time factor is removed which gives the customer a higher quality product with the fastest productivity.

- **Fast response:** Infrared sensors respond faster than thermocouples. This is important for moving products where a thermocouple cannot

respond in a short amount of time. The process temperature can be controlled tighter with a faster responding sensor, increasing the quality of the product and process.

- **Reduced downtime:** A thermocouple must make physical contact with the object that it is measuring. If that object moves or vibrates the thermocouple will fail and must be replaced. The replacement cost of the thermocouple plus the cost of downtime can be extremely high. Since an infrared sensor does not make any physical contact, there is no cost associated with replacement and downtime.

Application Guide

Temperature Sensors

Non-Contact Temperature Sensor Basics

Continued

- Automation:** An infrared sensor can be used to automate many existing processes. An infrared sensor can not only determine the temperature of an object, but can also determine absence or presence of an object. Indexing a product to the next operation can

be done via an infrared sensor rather than an operator. The infrared sensor can also be used as an automated inspector that checks the temperature of each product passing under the sensor, thus rejecting bad products.

- Contamination free:** Food processing, chemical and pharmacological applications that use contact devices to monitor temperature can be a nuisance. The contact device must be cleaned

and sterilized before the device can be used. If the device is not clean, the entire process must be rejected. An infrared sensor does not contact the process and can not contaminate.

The Watlow Infrared sensor can also be interfaced with Watlow temperature controllers to provide a closed-loop, non-contact temperature control system with options for serial data communications and data logging.

What is Infrared Energy?

Infrared energy is radiation released by an object that is above absolute zero temperature. All objects with a temperature above absolute zero (0 Kelvin) emit radiant energy. As an object is heated, molecular activity increases. As molecules become more active, they collide and release energy.

Infrared energy is emitted from an object as electromagnetic waves. These waves are invisible to the human eye, but have the same characteristics as visible light.

Electromagnetic waves are produced over a wide range of frequencies as categorized in Reference 42.

The infrared band that has any useable level of intensity for temperature measurement is in the 0.72 to 20 micron range. There is a distinct relationship between the temperature of an object and the amount of energy emitted from the object. The theory behind infrared thermometry is that the amount of measurable emitted energy relates to an object's temperature.

The amount of energy emitted from an object is determined using the Stefan-Boltzmann Equation:

$$W = eS T^4$$

W = Energy

e = Emissivity

The Electromagnetic Spectrum—Ref. 42



S = Stefan-Boltzmann Constant

T = Absolute Temperature of Object

From this equation we see that the emissivity and absolute temperature influence the amount of emitted radiation. The radiation is proportional to the fourth power of the absolute temperature of the source. That is, if the absolute temperature of the source is doubled, the radiation is increased by a factor of 16.

There is a direct relationship between the amount of radiation given off by an object and its temperature value. An object at 540°C (1000°F) emits more radiation than an object at 260°C (500°F). An infrared sensor intercepts this radiation and produces an output signal based on the object's temperature, see Ref. 43.

Emitted Energy as a Function of Temperature

Ref. 43

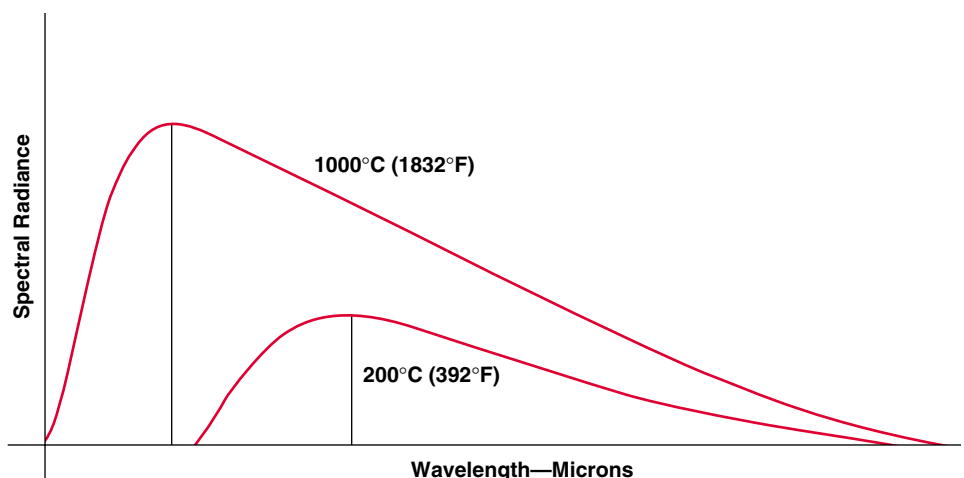

Application Guide

Temperature Sensors

Non-Contact Temperature Sensor Basics

Continued

Common Applications for Infrared Temperature Sensing

The following list represents areas where infrared temperature sensing is successfully applied. However, the application possibilities are much greater.

Ref. 44

| Industry | Application |
|-------------------|---|
| Chemicals | Drying powders, Adhesives Coatings, Film processing |
| Food | Packaging/sealing Baking ovens, Mixing Cooking and sterilization |
| Metals | Extrusion, Cold rolling |
| Automotive | Paint preheating and drying ovens |
| Plastics | Thermoforming Vacuum forming Injection molding Packaging and sealing |
| Ovens | Coating, Paint curing Laminating, Forming truck bed liners |
| Paper | Roller temperature Printing, Drying |
| Textiles | Drying, Printing Silkscreening, Heat setting |
| Medical | Blood temperature Research |
| Lumber | Determining moisture content |
| Packaging | Heat sealing Preheating, Bottling |
| Laminating | Laminating TV, CRT cabinets |

Emissivity

A material's emissivity value also affects the amount of radiation emitted by an object. Emissivity is a measure of an object's ability to either emit or absorb radiant energy. Emissivity values range from 0 to 1.0 and are typically obtained from tables or determined experimentally.

A surface having an emissivity of "0" indicates a perfect reflector. This surface neither absorbs nor emits radiant energy. One can conclude that surfaces having low emissivity values (polished surfaces, highly reflective) are not good candidates for infrared sensing.

A surface having an emissivity of 1.0 is called a "blackbody." This surface emits 100 percent of the energy supplied to it or absorbs 100 percent of the energy intercepted by it.

Theoretically, a blackbody is an ideal surface, one that doesn't really exist. All other surfaces have emissivities less than one and are referred to as "graybodies." The term blackbody is somewhat of a misnomer. If a surface is the color black, it doesn't necessarily mean it has an emissivity of 1.0.

When applying an infrared sensor, it is best if the surface has an emissivity of at least 0.5. A surface with a low emissivity value can be enhanced by:

- Texturizing the surface (sanding or sandblasting)
- Oxidizing the surface
- Anodizing the surface
- Painting the surface with a dull, high absorbent coating

Application Guide

Temperature Sensors

Non-Contact Temperature Sensor Basics

Continued

What Happens to Emitted Energy?

Reference 45 illustrates what happens to emitted energy once it has been intercepted by an object.

Emitted Energy

Ref. 45

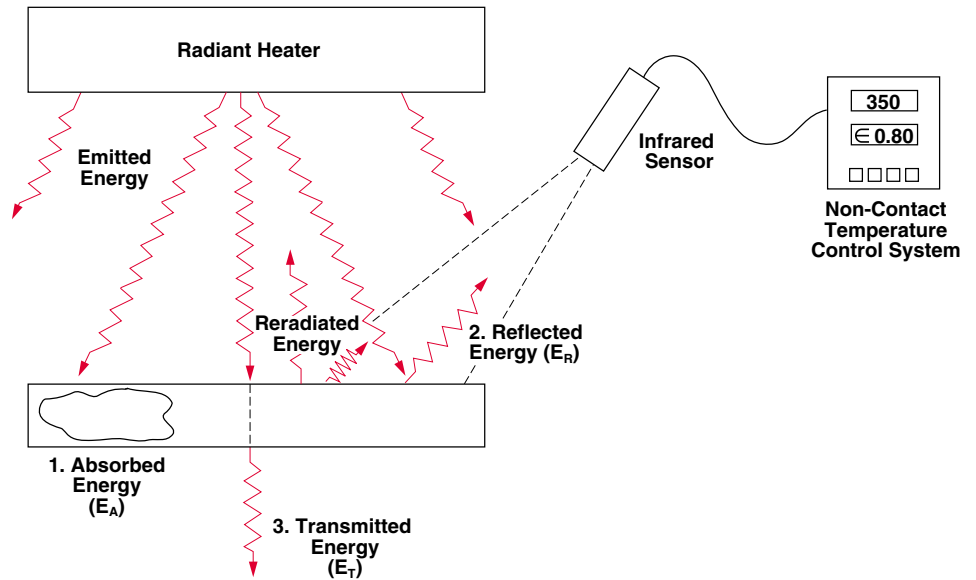

When the emitted energy is intercepted by an object, a combination of three events will happen:

1. Part of the emitted energy is absorbed by the object, causing its temperature to increase.
2. Some of the energy is reflected by the object's surface, and has no effect on the object's temperature.
3. Some of the energy will be transmitted through that object, having no effect on the object's temperature.

The energy values of all three of these events will always total the amount of energy originally intercepted by the object.

This is called the conservation of energy. As a formula, it's expressed as:

$$E_A + E_R + E_T = 1.0$$

E_A = Absorbed Energy

E_R = Reflected Energy

E_T = Transmitted Energy

The amount of energy absorbed by the object depends upon the object's

emissivity, the wavelength of the energy striking the object and its angle of incidence.

Example: If the object in the above illustration has an emissivity of 0.8, this implies the object absorbs 80 percent of the energy striking its surface. Relating back to the conservation of energy equation, if $E_A = 80$ percent, then the sum of the reflected energy (E_R) and transmitted energy (E_T) is 20 percent. The total of all three is 100 percent of the energy intercepted by the object's surface.

As the object heats up, it starts to reradiate or emit energy on its own. The amount of energy reradiated depends on the temperature of the object and its emissivity. An infrared sensor produces its output signal by intercepting a combination of an object's reradiated (emitted) and reflected energy. An emissivity adjustment on the sensor allows the sensor to compensate for the amount of emitted and reflected energy, thus detecting the "true" object temperature.

Application Guide

Temperature Sensors

Non-Contact Temperature Sensor Basics

Continued

How Does an Infrared Sensor Work?

A non-contact temperature control system consists of:

- Precision Optics
- Infrared Detector
- Sensor Housing
- Support Electronics

There is a distinct relationship between an object's temperature and the amount of energy that is given off by the object. An infrared sensor

Characteristics of an Infrared System:

Ref. 46

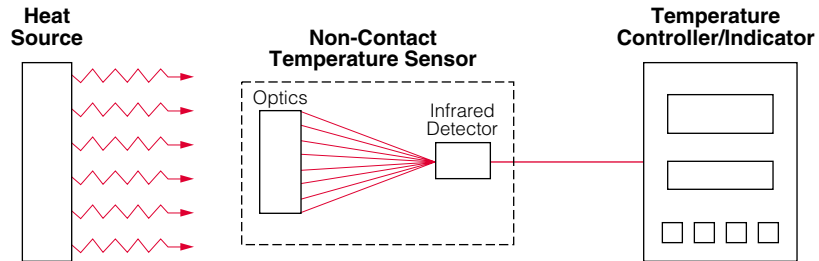

intercepts a portion of the total emitted energy and concentrates it onto an infrared detector. The detector produces a signal output proportional to the amount of incoming infrared energy. This signal

is then transmitted to the support electronics through a cable. The signal is amplified, linearized and conditioned by the support electronics.

Factors to Consider When Using Infrared Temperature Sensing

1. Material

The sensor should be used to measure materials that have a high emissivity. The surface condition and the type of material have an affect on the emissivity. Materials such as rubber, textiles, paper, thick plastic (greater than 20 mils), painted surfaces, glass and wood are examples of materials with a high emissivity.

The sensor can measure materials that are transparent to visible light (materials that we can see through), assuming that the material is not too thin (less than 10 mils thick). Materials such as plate glass and clear acrylic sheets have a very high emissivity and are excellent infrared sensor application.

Where can a Watlow IR sensor be applied:

- Food
- Plastic
- Paper
- Paint
- Liquids
- Any material that has a high emissivity
- Rubber
- Glass
- Wood
- Textiles
- Chemicals

Where not to apply a Watlow IR sensor:

- Transmissive materials
Thin film plastics usually less than 10 mils
- Reflective materials
Polished, uncoated metals
Brass, copper, stainless steel

2. Sensor/Target Distance

Position the infrared sensor so the object fills the sensor's entire field-of-view. Position #1 in Reference 47 shows proper sensor placement. The sensor is looking at the object and not picking up background radiation (noise). Position #2 illustrates incorrect sensor placement.

Ref. 47

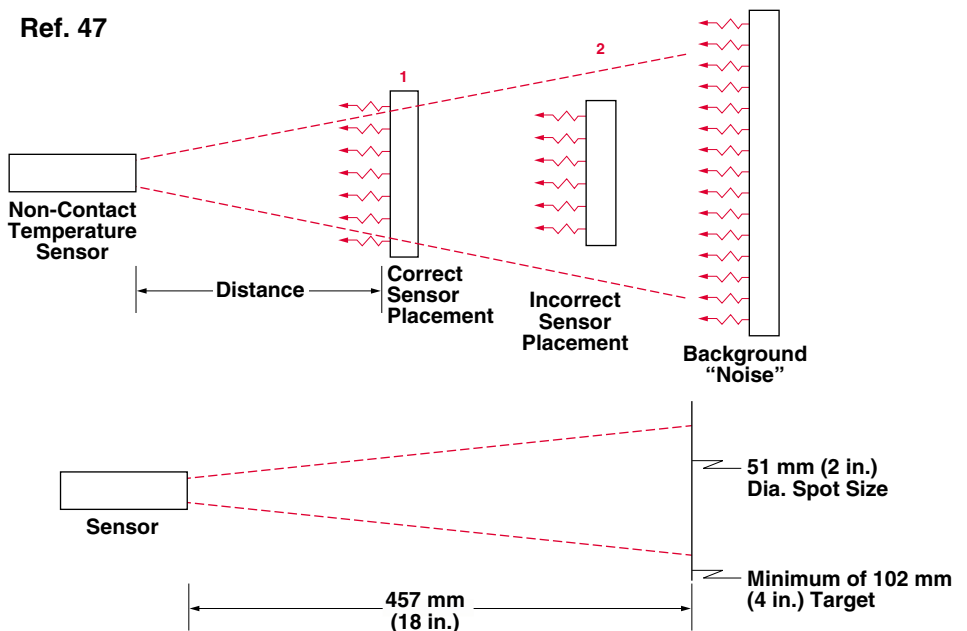

Application Guide

Temperature Sensors

Non-Contact Temperature Sensor Basics

Continued

The sensor is “looking” at the object as well as at background radiation; thus, it will average background energy with the energy emitted by the target object. All background surfaces around the target emit radiant energy according to the basic laws. If the background radiation is within the spectral transmission (eight-14 microns) of the sensor, an error in the indicated temperature will occur. This background radiation can be energy emitted from lamps, heaters, ovens, heat exchangers, motors, generators, steam pipes, etc. As a general rule of thumb, to minimize the effects of background radiation, the target size should be two times larger than the desired spot size. For example, if an object is 457 mm (18 in.) away and the spot size is rated for 51 mm (2 in.), the target should be at least 102 mm (4 in.) in size.

3. Ambient Temperature

Check the operating ambient temperature of the infrared sensor.

Due to the thermal dynamics of the infrared sensor, **it is normal for the output to drift when the sensor is**

exposed to a dramatically changing ambient. The sensor output will stabilize when the ambient temperature stabilizes. The sensor is accurate when maintained at a constant ambient temperature.

Air and/or water cooling jackets may be available to help maintain the sensor at an appropriate operating ambient temperature.

4. Sensor Placement

Ideally, the temperature sensor should be placed at a right angle with respect to the target. This helps reduce the effects of reflected energy. Not all applications will lend themselves to perpendicular sensor placement. In these situations, do not position the sensor at more than a 45° angle normal to the surface (see Reference 48).

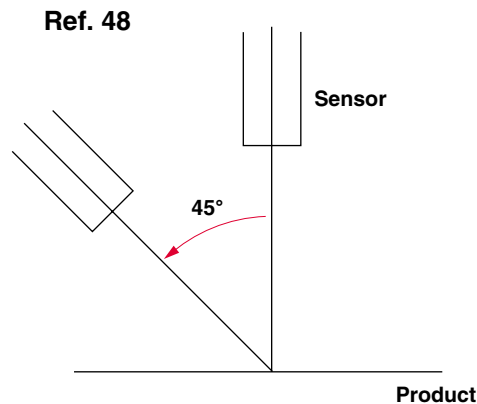

5. Environment

Dust, gases, suspended water vapor and other particulate matter can affect the infrared sensor's performance. These items can intercept, absorb or scatter infrared energy before it gets to the sensor. Therefore, it is best if the environment is kept fairly clean and free of contaminants. An air purge collar is available to purge the optics systems to prevent the accumulation of foreign material on the lens.

Application Guide

The Art of Temperature Sensing

Defining an Application and Determining a Solution

This section deals with the major factors you should consider when deciding on a solution to an application problem. This is not meant to be all inclusive; as the matrix of possible combinations involved can lead to solutions too numerous to include in the limited space available. However, it will give

you an idea of how a decision on one aspect of a sensor choice will affect another. The objective is always to arrive at an optimum solution... a solution that allows you to satisfy your temperature sensing needs, given the limits of temperature sensing technology.

Determining Application Objective and Requirements

The first step is to establish an objective and determine the requirements to reach that objective. These include:

- Does the application require contact or non-contact temperature sensing?
- How accurate must the temperature reading be?
- What temperature range is involved?
- What's the maximum temperature the sensor will be exposed to?
- How fast must the sensor respond to a temperature change and deliver an accurate reading?
- How long should the stability and accuracy of the sensor last?
- What environmental restraints exist and what protection devices will solve those restraints with sufficient ruggedness?
- What cost, or economic restraints are involved?

Decisions resulting from the above will tend to lead to one sensor type over others.

If an object or process would be defaced or contaminated by contact

sensing; or the process moves making contact sensing impractical, then infrared temperature sensing will be your method.

If you choose contact sensing, the degree of accuracy and temperature range will help decide the type of sensor. In general, a platinum wire RTD will provide the best overall accuracy, for the largest temperature range, for the longest time. However, its cost may prohibit its use if economy is a factor. This leads to deciding among thermocouples and thermistors. The limited temperature range of thermistors may preclude their use. In that case, you're limited to selecting a sensor from the available types and/or calibrations of thermocouples.

The degree of responsiveness depends on both the type of sensor and size. Sensor mass has thermal inertia that must be overcome. This also involves any protecting device used to shield the sensor from its environment. The relationships between the sensor's mass and thermal conductivity, protecting device mass and thermal conductivity, and that of the substance or object being measured will affect the degree of responsiveness.

An integral part of thermocouple responsiveness involves how long the sensor needs to last and with what degree of stability. The larger the conductor gauge, the longer the life with greater stability. This also affects response as larger gauges also pose greater mass and thermal inertia.

When sensors are used in hostile environments and need protection to extend life, the style, size and material of the protecting device will affect the sensor's response. Again, it's a combination of the protecting device's size (or mass), the thermal conductivity of its material, the effectiveness of the thermal contact between the sensor and protecting device, and the thermal contact between the protecting device with its surrounding substance. All this affects how efficiently heat energy is transferred back to the sensor element.

Economy then dictates if the specifications set to achieve accuracy, response and life requirements can be financially justified. This has more impact on applications that use a sensor in a product. Obviously, the more expensive the sensor, and/or protecting device, the more expensive the final product.

Sensor Location

Once the above have been considered and an optimum sensor construction arrived at, sensor location is the next application problem to determine and solve. If an application is isothermal, sensor location is a simple matter of convenient location with sufficient

contact to what's being measured. In a thermally dynamic application, location of the sensor relative to the heat source and load has an impact on accuracy and response.

The following covers contact sensor placement in a thermal system.

Application Guide

Reference Data

Thermocouple and Resistance Wire RTD Initial Calibration Tolerances

Reference data for thermocouples derived from ASTM E230. Reference data for RTD sensors derived from IEC 60751.

Initial Calibration Tolerances for Thermoelements and Resistance Wire RTDs—Ref. 49

| Temperature °C (°F) | | Initial Calibration Tolerances (±°F) | | | | | | | | | | | | |
|------------------------|--------|--------------------------------------|------|--------|--------|------|--------|------|-----------|------|-----------|------|--------|------|
| | | Thermocouple | | | | | | | | | | | | |
| | | RTD, DIN or JIS | | Type B | Type E | | Type J | | Type K, N | | Type R, S | | Type T | |
| | | A | B | STD | STD | SPL | STD | SPL | STD | SPL | STD | SPL | STD | SPL |
| -184 | (-300) | 0.93 | 2.2 | | 3.32 | | | | 6.64 | | | | 4.98 | |
| -157 | (-250) | 0.83 | 1.95 | | 3.06 | | | | 5.64 | | | | 4.23 | |
| -129 | (-200) | 0.73 | 1.7 | | 3.06 | | | | 4.64 | | | | 3.48 | |
| -101 | (-150) | 0.63 | 1.45 | | 3.06 | | | | 3.96 | | | | 2.73 | |
| -73 | (-100) | 0.53 | 1.2 | | 3.06 | | | | 3.96 | | | | 1.98 | |
| -46 | (-50) | 0.43 | 0.95 | | 3.06 | | | | 3.96 | | | | 1.80 | 0.90 |
| -18 | (0) | 0.33 | 0.7 | | 3.06 | 1.80 | | | 3.96 | | | | 1.80 | 0.90 |
| 0 | (32) | 0.27 | 0.54 | | 3.06 | 1.80 | 3.96 | 1.98 | 3.96 | 1.98 | 2.70 | 1.08 | 1.80 | 0.90 |
| 10 | (50) | 0.31 | 0.63 | | 3.06 | 1.80 | 3.96 | 1.98 | 3.96 | 1.98 | 2.70 | 1.08 | 1.80 | 0.90 |
| 38 | (100) | 0.41 | 0.88 | | 3.06 | 1.80 | 3.96 | 1.98 | 3.96 | 1.98 | 2.70 | 1.08 | 1.80 | 0.90 |
| 66 | (150) | 0.51 | 1.13 | | 3.06 | 1.80 | 3.96 | 1.98 | 3.96 | 1.98 | 2.70 | 1.08 | 1.80 | 0.90 |
| 93 | (200) | 0.61 | 1.38 | | 3.06 | 1.80 | 3.96 | 1.98 | 3.96 | 1.98 | 2.70 | 1.08 | 1.80 | 0.90 |
| 121 | (250) | 0.71 | 1.63 | | 3.06 | 1.80 | 3.96 | 1.98 | 3.96 | 1.98 | 2.70 | 1.08 | 1.80 | 0.90 |
| 149 | (300) | 0.81 | 1.88 | | 3.06 | 1.80 | 3.96 | 1.98 | 3.96 | 1.98 | 2.70 | 1.08 | 2.01 | 1.07 |
| 177 | (350) | 0.91 | 2.13 | | 3.06 | 1.80 | 3.96 | 1.98 | 3.96 | 1.98 | 2.70 | 1.08 | 2.39 | 1.27 |
| 204 | (400) | 1.01 | 2.38 | | 3.06 | 1.80 | 3.96 | 1.98 | 3.96 | 1.98 | 2.70 | 1.08 | 2.76 | 1.47 |
| 232 | (450) | 1.11 | 2.63 | | 3.06 | 1.80 | 3.96 | 1.98 | 3.96 | 1.98 | 2.70 | 1.08 | 3.14 | 1.67 |
| 260 | (500) | 1.21 | 2.88 | | 3.06 | 1.87 | 3.96 | 1.98 | 3.96 | 1.98 | 2.70 | 1.08 | 3.51 | 1.87 |
| 288 | (550) | 1.31 | 3.13 | | 3.06 | 2.07 | 3.96 | 2.07 | 3.96 | 2.07 | 2.70 | 1.08 | 3.89 | 2.07 |
| 316 | (600) | 1.41 | 3.38 | | 3.06 | 2.27 | 4.26 | 2.27 | 4.26 | 2.27 | 2.70 | 1.08 | 4.26 | 2.27 |
| 343 | (650) | 1.51 | 3.63 | | 3.09 | 2.47 | 4.64 | 2.47 | 4.64 | 2.47 | 2.70 | 1.08 | 4.64 | 2.47 |
| 371 | (700) | 1.61 | 3.88 | | 3.34 | 2.67 | 5.01 | 2.67 | 5.01 | 2.67 | 2.70 | 1.08 | | |
| 399 | (750) | 1.71 | 4.13 | | 3.59 | 2.87 | 5.39 | 2.87 | 5.39 | 2.87 | 2.70 | 1.08 | | |
| 427 | (800) | 1.81 | 4.38 | | 3.84 | 3.07 | 5.76 | 3.07 | 5.76 | 3.07 | 2.70 | 1.08 | | |
| 454 | (850) | 1.91 | 4.63 | | 4.09 | 3.27 | 6.14 | 3.27 | 6.14 | 3.27 | 2.70 | 1.08 | | |
| 482 | (900) | 2.01 | 4.88 | | 4.34 | 3.47 | 6.51 | 3.47 | 6.51 | 3.47 | 2.70 | 1.08 | | |
| 510 | (950) | 2.11 | 5.13 | | 4.59 | 3.67 | 6.89 | 3.67 | 6.89 | 3.67 | 2.70 | 1.08 | | |
| 538 | (1000) | 2.21 | 5.38 | | 4.84 | 3.87 | 7.26 | 3.87 | 7.26 | 3.87 | 2.70 | 1.08 | | |
| 566 | (1050) | 2.31 | 5.63 | | 5.09 | 4.07 | 7.64 | 4.07 | 7.64 | 4.07 | 2.70 | 1.08 | | |
| 593 | (1100) | 2.41 | 5.88 | | 5.34 | 4.27 | 8.01 | 4.27 | 8.01 | 4.27 | 2.70 | 1.08 | | |
| 621 | (1150) | 2.51 | 6.13 | | 5.59 | 4.47 | 8.39 | 4.47 | 8.39 | 4.47 | 2.80 | 1.12 | | |
| 649 | (1200) | 2.61 | 6.38 | | 5.84 | 4.67 | 8.76 | 4.67 | 8.76 | 4.67 | 2.92 | 1.17 | | |
| 677 | (1250) | | | | 6.09 | 4.87 | 9.14 | 4.87 | 9.14 | 4.87 | 3.05 | 1.22 | | |
| 704 | (1300) | | | | 6.34 | 5.07 | 9.51 | 5.07 | 9.51 | 5.07 | 3.17 | 1.27 | | |
| 732 | (1350) | | | | 6.59 | 5.27 | 9.89 | 5.27 | 9.89 | 5.27 | 3.30 | 1.32 | | |
| 760 | (1400) | | | | 6.84 | 5.47 | | | 10.26 | 5.47 | 3.42 | 1.37 | | |
| 788 | (1450) | | | | 7.09 | 5.67 | | | 10.64 | 5.67 | 3.55 | 1.42 | | |
| 816 | (1500) | | | | 7.34 | 5.87 | | | 11.01 | 5.87 | 3.67 | 1.47 | | |
| 843 | (1550) | | | | 7.59 | 6.07 | | | 11.39 | 6.07 | 3.80 | 1.52 | | |
| 871 | (1600) | | | 7.84 | 7.84 | 6.27 | | | 11.76 | 6.27 | 3.92 | 1.57 | | |

Temperature Sensors

CONTINUED

Application Guide

Reference Data

Thermocouple and Resistance Wire RTD Initial Calibration Tolerances

Continued

| Temperature °C (°F) | | RTD DIN or JIS A B | | Initial Calibration Tolerances (±°F) | | | | | | | | | |
|------------------------|------|--------------------------|--|--------------------------------------|-------------------|--|-------------------|-------|----------------------|------|----------------------|--|-------------------|
| | | | | Thermocouple | | | | | | | | | |
| | | | | Type B STD | Type E STD SPL | | Type J STD SPL | | Type K, N STD SPL | | Type R, S STD SPL | | Type T STD SPL |
| 899 | 1650 | | | 8.09 | | | | 12.14 | 6.47 | 4.05 | 1.62 | | |
| 927 | 1700 | | | 8.34 | | | | 12.51 | 6.67 | 4.17 | 1.67 | | |
| 954 | 1750 | | | 8.59 | | | | 12.89 | 6.87 | 4.30 | 1.72 | | |
| 982 | 1800 | | | 8.84 | | | | 13.26 | 7.07 | 4.42 | 1.77 | | |
| 1010 | 1850 | | | 9.09 | | | | 13.64 | 7.27 | 4.55 | 1.82 | | |
| 1038 | 1900 | | | 9.34 | | | | 14.01 | 7.47 | 4.67 | 1.87 | | |
| 1066 | 1950 | | | 9.59 | | | | 14.39 | 7.67 | 4.80 | 1.92 | | |
| 1093 | 2000 | | | 9.84 | | | | 14.76 | 7.87 | 4.92 | 1.97 | | |
| 1121 | 2050 | | | 10.09 | | | | 15.14 | 8.07 | 5.05 | 2.02 | | |
| 1149 | 2100 | | | 10.34 | | | | 15.51 | 8.27 | 5.17 | 2.07 | | |
| 1177 | 2150 | | | 10.59 | | | | 15.89 | 8.47 | 5.30 | 2.12 | | |
| 1204 | 2200 | | | 10.84 | | | | 16.26 | 8.67 | 5.42 | 2.17 | | |
| 1232 | 2250 | | | 11.09 | | | | 16.64 | 8.87 | 5.55 | 2.22 | | |
| 1260 | 2300 | | | 11.34 | | | | 17.01 | 9.07 | 5.67 | 2.27 | | |
| 1288 | 2350 | | | 11.59 | | | | | | 5.87 | 2.32 | | |
| 1316 | 2400 | | | 11.84 | | | | | | 5.92 | 2.37 | | |
| 1343 | 2450 | | | 12.09 | | | | | | 6.05 | 2.42 | | |
| 1371 | 2500 | | | 12.34 | | | | | | 6.17 | 2.47 | | |
| 1399 | 2550 | | | 12.59 | | | | | | 6.30 | 2.52 | | |
| 1427 | 2600 | | | 12.84 | | | | | | 6.42 | 2.57 | | |
| 1454 | 2650 | | | 13.09 | | | | | | | | | |
| 1482 | 2700 | | | 13.34 | | | | | | | | | |
| 1510 | 2750 | | | 13.59 | | | | | | | | | |
| 1538 | 2800 | | | 13.84 | | | | | | | | | |
| 1566 | 2850 | | | 14.09 | | | | | | | | | |
| 1593 | 2900 | | | 14.34 | | | | | | | | | |
| 1621 | 2950 | | | 14.59 | | | | | | | | | |
| 1649 | 3000 | | | 14.84 | | | | | | | | | |
| 1677 | 3050 | | | 15.09 | | | | | | | | | |
| 1704 | 3100 | | | 15.34 | | | | | | | | | |

Notes:

- To convert tolerances to Celsius multiply by 5/9 (0.55555).
- Tolerances in the cryogenic range (<0°C) may not apply to standard thermocouple materials. Purchase order must state that materials are to be used in cryogenic range.
- Tolerances listed may not apply after exposure to heat or cold.

Application Guide

Reference Data

RTD Resistance vs. Temperature Tables Standard Thermistors

Reference charts and tables for thermistors and platinum RTDs courtesy of the American Society for Testing and Materials. Taken from publication STP 470B, "Manual on the Use of Thermocouples in Temperature Measurement."

The following tables contain the Temperature vs. Resistance values for thermistors, and DIN and JIS platinum RTDs.

No. 10—300 Ohms—Ref. 50

| Temp (°C) | R Value Ohms | Temp. (°C) | R Value Ohms | Temp. (°C) | R Value Ohms | Temp. (°C) | R Value Ohms |
|-----------|--------------|------------|--------------|------------|--------------|------------|--------------|
| (-80) | 50,763 | (-39) | 4,554 | (2) | 709.5 | (43) | 164.7 |
| (-79) | 47,473 | (-38) | 4,327 | (3) | 681.8 | (44) | 159.6 |
| (-78) | 44,417 | (-37) | 4,113 | (4) | 655.3 | (45) | 154.7 |
| (-77) | 41,576 | (-36) | 3,910 | (5) | 630.0 | (46) | 149.9 |
| (-76) | 38,935 | (-35) | 3,719 | (6) | 605.8 | (47) | 145.3 |
| (-75) | 36,477 | (-34) | 3,538 | (7) | 582.7 | (48) | 140.9 |
| (-74) | 34,190 | (-33) | 3,367 | (8) | 560.5 | (49) | 136.6 |
| (-73) | 32,060 | (-32) | 3,205 | (9) | 539.4 | (50) | 132.5 |
| (-72) | 30,076 | (-31) | 3,052 | (10) | 519.1 | (51) | 128.5 |
| (-71) | 28,227 | (-30) | 2,907 | (11) | 499.7 | (52) | 124.7 |
| (-70) | 26,503 | (-29) | 2,769 | (12) | 481.2 | (53) | 121.0 |
| (-69) | 24,895 | (-28) | 2,639 | (13) | 463.4 | (54) | 117.5 |
| (-68) | 23,394 | (-27) | 2,516 | (14) | 446.4 | (55) | 114.0 |
| (-67) | 21,993 | (-26) | 2,400 | (15) | 430.1 | (56) | 110.7 |
| (-66) | 20,684 | (-25) | 2,289 | (16) | 414.5 | (57) | 107.5 |
| (-65) | 19,461 | (-24) | 2,184 | (17) | 399.6 | (58) | 104.4 |
| (-64) | 18,318 | (-23) | 2,085 | (18) | 385.2 | (59) | 101.4 |
| (-63) | 17,249 | (-22) | 1,990 | (19) | 371.5 | (60) | 98.5 |
| (-62) | 16,248 | (-21) | 1,901 | (20) | 358.3 | (61) | 95.7 |
| (-61) | 15,312 | (-20) | 1,816 | (21) | 345.7 | (62) | 93.0 |
| (-60) | 14,436 | (-19) | 1,735 | (22) | 333.5 | (63) | 90.4 |
| (-59) | 13,614 | (-18) | 1,659 | (23) | 321.9 | (64) | 87.8 |
| (-58) | 12,845 | (-17) | 1,586 | (24) | 310.7 | (65) | 85.4 |
| (-57) | 12,123 | (-16) | 1,516 | (25) | 300.0 | (66) | 83.0 |
| (-56) | 11,447 | (-15) | 1,451 | (26) | 289.7 | (67) | 80.7 |
| (-55) | 10,812 | (-14) | 1,388 | (27) | 279.8 | (68) | 78.5 |
| (-54) | 10,216 | (-13) | 1,328 | (28) | 270.3 | (69) | 76.4 |
| (-53) | 9,656 | (-12) | 1,272 | (29) | 261.2 | (70) | 74.3 |
| (-52) | 9,131 | (-11) | 1,218 | (30) | 252.4 | (71) | 72.3 |
| (-51) | 8,637 | (-10) | 1,167 | (31) | 244.0 | (72) | 70.4 |
| (-50) | 8,173 | (-9) | 1,118 | (32) | 235.9 | (73) | 68.5 |
| (-49) | 7,737 | (-8) | 1,071 | (33) | 228.1 | (74) | 66.7 |
| (-48) | 7,326 | (-7) | 1,027 | (34) | 220.6 | (75) | 64.9 |
| (-47) | 6,940 | (-6) | 984.5 | (35) | 213.4 | (76) | 63.2 |
| (-46) | 6,576 | (-5) | 944.2 | (36) | 206.5 | (77) | 61.6 |
| (-45) | 6,234 | (-4) | 905.8 | (37) | 199.8 | (78) | 60.0 |
| (-44) | 5,911 | (-3) | 869.1 | (38) | 193.4 | (79) | 58.4 |
| (-43) | 5,607 | (-2) | 834.2 | (39) | 187.2 | (80) | 56.9 |
| (-42) | 5,320 | (-1) | 800.8 | (40) | 181.3 | (81) | 55.4 |
| (-41) | 5,050 | (0) | 769.0 | (41) | 175.5 | (82) | 54.0 |
| (-40) | 4,795 | (1) | 738.6 | (42) | 170.0 | (83) | 52.7 |

Temperature Sensors

CONTINUED

Application Guide

Reference Data

RTD Resistance vs. Temperature Tables

Standard Thermistors

Continued

No. 10—300 Ohms—Ref. 50

| Temp (°C) | R Value Ohms | Temp. (°C) | R Value Ohms | Temp. (°C) | R Value Ohms | Temp. (°C) | R Value Ohms |
|-----------|--------------|------------|--------------|------------|--------------|------------|--------------|
| (84) | 51.3 | (101) | 33.8 | (118) | 23.1 | (135) | 16.2 |
| (85) | 50.0 | (102) | 33.0 | (119) | 22.6 | (136) | 15.9 |
| (86) | 48.8 | (103) | 32.3 | (120) | 22.1 | (137) | 15.6 |
| (87) | 47.6 | (104) | 31.5 | (121) | 21.6 | (138) | 15.3 |
| (88) | 46.4 | (105) | 30.8 | (122) | 21.1 | (139) | 15.0 |
| (89) | 45.3 | (106) | 30.1 | (123) | 20.7 | (140) | 14.7 |
| (90) | 44.1 | (107) | 29.4 | (124) | 20.3 | (141) | 14.4 |
| (91) | 43.1 | (108) | 28.8 | (125) | 19.9 | (142) | 14.1 |
| (92) | 42.0 | (109) | 28.1 | (126) | 19.5 | (143) | 13.8 |
| (93) | 41.0 | (110) | 27.5 | (127) | 19.1 | (144) | 13.6 |
| (94) | 40.0 | (111) | 26.9 | (128) | 18.7 | (145) | 13.3 |
| (95) | 39.1 | (112) | 26.3 | (129) | 18.3 | (146) | 13.1 |
| (96) | 38.1 | (113) | 25.7 | (130) | 17.9 | (147) | 12.8 |
| (97) | 37.2 | (114) | 25.2 | (131) | 17.5 | (148) | 12.6 |
| (98) | 36.4 | (115) | 24.6 | (132) | 17.2 | (149) | 12.3 |
| (99) | 35.5 | (116) | 24.1 | (133) | 16.9 | (150) | 12.1 |
| (100) | 34.6 | (117) | 23.7 | (134) | 16.5 | | |

No. 11—1000 Ohms—Ref. 51

| Temp (°C) | R Value Ohms | Temp. (°C) | R Value Ohms | Temp. (°C) | R Value Ohms | Temp. (°C) | R Value Ohms |
|-----------|--------------|------------|--------------|------------|--------------|------------|--------------|
| (-80) | 233,516 | (-60) | 60,386 | (-40) | 18,641 | (-20) | 6,662 |
| (-79) | 217,298 | (-59) | 56,717 | (-39) | 17,649 | (-19) | 6,350 |
| (-78) | 202,147 | (-58) | 53,294 | (-38) | 16,716 | (-18) | 6,053 |
| (-77) | 188,227 | (-57) | 50,099 | (-37) | 15,837 | (-17) | 5,773 |
| (-76) | 175,258 | (-56) | 47,116 | (-36) | 15,010 | (-16) | 5,507 |
| (-75) | 163,454 | (-55) | 44,329 | (-35) | 14,231 | (-15) | 5,255 |
| (-74) | 152,435 | (-54) | 41,725 | (-34) | 13,498 | (-14) | 5,016 |
| (-73) | 142,234 | (-53) | 39,289 | (-33) | 12,806 | (-13) | 4,709 |
| (-72) | 132,779 | (-52) | 37,012 | (-32) | 12,154 | (-12) | 4,574 |
| (-71) | 124,017 | (-51) | 34,881 | (-31) | 11,540 | (-11) | 4,369 |
| (-70) | 115,888 | (-50) | 32,886 | (-30) | 10,960 | (-10) | 4,175 |
| (-69) | 108,347 | (-49) | 31,016 | (-29) | 10,412 | (-9) | 3,991 |
| (-68) | 101,343 | (-48) | 29,266 | (-28) | 9,896 | (-8) | 3,816 |
| (-67) | 94,837 | (-47) | 27,624 | (-27) | 9,408 | (-7) | 3,649 |
| (-66) | 88,793 | (-46) | 26,085 | (-26) | 8,947 | (-6) | 3,491 |
| (-65) | 83,171 | (-45) | 24,642 | (-25) | 8,511 | (-5) | 3,341 |
| (-64) | 77,942 | (-44) | 23,286 | (-24) | 8,100 | (-4) | 3,198 |
| (-63) | 73,075 | (-43) | 22,014 | (-23) | 7,709 | (-3) | 3,061 |
| (-62) | 68,544 | (-42) | 20,819 | (-22) | 7,341 | (-2) | 2,932 |
| (-61) | 64,321 | (-41) | 19,697 | (-21) | 6,992 | (-1) | 2,808 |

CONTINUED 

Application Guide

Reference Data

RTD Resistance vs. Temperature Tables

Standard Thermistors

Continued

No. 11—1000 Ohms—Ref. 51 cont.

| Temp (°C) | R Value Ohms | Temp. (°C) | R Value Ohms | Temp. (°C) | R Value Ohms | Temp. (°C) | R Value Ohms |
|-----------|--------------|------------|--------------|------------|--------------|------------|--------------|
| (0) | 2,691 | (38) | 630.6 | (76) | 194.9 | (114) | 74.2 |
| (1) | 2,579 | (39) | 609.5 | (77) | 189.5 | (115) | 72.5 |
| (2) | 2,472 | (40) | 589.2 | (78) | 184.3 | (116) | 70.8 |
| (3) | 2,371 | (41) | 569.6 | (79) | 179.3 | (117) | 69.2 |
| (4) | 2,274 | (42) | 550.8 | (80) | 174.5 | (118) | 67.7 |
| (5) | 2,182 | (43) | 532.8 | (81) | 169.8 | (119) | 66.1 |
| (6) | 2,094 | (44) | 515.4 | (82) | 165.2 | (120) | 64.7 |
| (7) | 2,009 | (45) | 498.7 | (83) | 168.8 | (121) | 63.2 |
| (8) | 1,929 | (46) | 482.6 | (84) | 156.6 | (122) | 61.8 |
| (9) | 1,853 | (47) | 467.1 | (85) | 152.4 | (123) | 60.5 |
| (10) | 1,780 | (48) | 452.2 | (86) | 148.4 | (124) | 59.2 |
| (11) | 1,710 | (49) | 437.8 | (87) | 144.6 | (125) | 57.9 |
| (12) | 1,643 | (50) | 424.0 | (88) | 140.8 | (126) | 56.6 |
| (13) | 1,579 | (51) | 410.7 | (89) | 137.2 | (127) | 55.4 |
| (14) | 1,519 | (52) | 397.8 | (90) | 133.6 | (128) | 54.2 |
| (15) | 1,460 | (53) | 385.5 | (91) | 130.2 | (129) | 53.0 |
| (16) | 1,405 | (54) | 373.5 | (92) | 126.9 | (130) | 51.9 |
| (17) | 1,351 | (55) | 362.0 | (93) | 123.7 | (131) | 50.8 |
| (18) | 1,300 | (56) | 351.0 | (94) | 120.6 | (132) | 49.7 |
| (19) | 1,252 | (57) | 340.3 | (95) | 117.5 | (133) | 48.7 |
| (20) | 1,205 | (58) | 330.0 | (96) | 114.6 | (134) | 47.7 |
| (21) | 1,160 | (59) | 320.0 | (97) | 111.7 | (135) | 46.7 |
| (22) | 1,118 | (60) | 310.4 | (98) | 109.0 | (136) | 45.7 |
| (23) | 1,077 | (61) | 301.2 | (99) | 106.3 | (137) | 44.8 |
| (24) | 1,038 | (62) | 292.3 | (100) | 103.7 | (138) | 43.9 |
| (25) | 1,000 | (63) | 283.6 | (101) | 101.2 | (139) | 43.0 |
| (26) | 964.0 | (64) | 275.3 | (102) | 98.7 | (140) | 42.1 |
| (27) | 929.5 | (65) | 267.3 | (103) | 96.3 | (141) | 41.2 |
| (28) | 896.3 | (66) | 259.5 | (104) | 94.0 | (142) | 40.4 |
| (29) | 864.6 | (67) | 252.0 | (105) | 91.7 | (143) | 39.6 |
| (30) | 834.2 | (68) | 244.8 | (106) | 89.6 | (144) | 38.8 |
| (31) | 804.9 | (69) | 237.8 | (107) | 87.4 | (145) | 38.0 |
| (32) | 776.9 | (70) | 231.0 | (108) | 85.1 | (146) | 37.3 |
| (33) | 750.0 | (71) | 224.5 | (109) | 83.1 | (147) | 36.5 |
| (34) | 724.1 | (72) | 218.1 | (110) | 81.4 | (148) | 35.8 |
| (35) | 699.3 | (73) | 212.0 | (111) | 79.5 | (149) | 35.1 |
| (36) | 675.5 | (74) | 206.1 | (112) | 77.7 | (150) | 34.4 |
| (37) | 652.6 | (75) | 200.4 | (113) | 75.9 | | |

Temperature Sensors

Application Guide

Reference Data

RTD Resistance vs. Temperature Tables

Standard Thermistors

Continued

No. 12—3000 Ohms—Ref. 52

| Temp (°C) | R Value Ohms | Temp. (°C) | R Value Ohms | Temp. (°C) | R Value Ohms | Temp. (°C) | R Value Ohms |
|-----------|--------------|------------|--------------|------------|--------------|------------|--------------|
| (-80) | 2,189,062 | (-37) | 82,682 | (6) | 7,251.8 | (57) | 831.97 |
| (-79) | 2,003,162 | (-36) | 77,492 | (7) | 6,904.8 | (58) | 802.16 |
| (-78) | 1,834,293 | (-35) | 72,658 | (8) | 6,576.5 | (59) | 773.56 |
| (-77) | 1,680,803 | (-34) | 68,159 | (9) | 6,265.6 | (60) | 746.12 |
| (-76) | 1,541,203 | (-33) | 63,966 | (10) | 5,971.1 | (61) | 719.82 |
| (-75) | 1,414,129 | (-32) | 60,055 | (11) | 5,692.1 | (62) | 694.55 |
| (-74) | 1,298,393 | (-31) | 56,408 | (12) | 5,427.8 | (63) | 670.31 |
| (-73) | 1,189,906 | (-30) | 53,005 | (13) | 5,177.2 | (64) | 647.02 |
| (-72) | 1,096,689 | (-29) | 49,827 | (14) | 4,939.5 | (65) | 624.69 |
| (-71) | 1,008,889 | (-28) | 46,860 | (15) | 4,714.2 | (66) | 603.23 |
| (-70) | 928,683 | (-27) | 44,088 | (16) | 4,500.3 | (67) | 582.62 |
| (-69) | 855,409 | (-26) | 41,497 | (17) | 4,297.4 | (68) | 562.81 |
| (-68) | 788,394 | (-25) | 39,073 | (18) | 4,104.8 | (69) | 543.78 |
| (-67) | 727,056 | (-24) | 36,806 | (19) | 3,915.9 | (70) | 525.49 |
| (-66) | 670,919 | (-23) | 34,684 | (20) | 3,748.1 | (71) | 507.90 |
| (-65) | 619,476 | (-22) | 32,697 | (21) | 3,583.0 | (72) | 490.99 |
| (-64) | 572,319 | (-21) | 30,836 | (22) | 3,426.0 | (73) | 474.72 |
| (-63) | 529,062 | (-20) | 29,092 | (23) | 3,276.8 | (74) | 459.08 |
| (-62) | 489,352 | (-19) | 27,458 | (24) | 3,135.0 | (75) | 444.04 |
| (-61) | 452,892 | (-18) | 25,924 | (25) | 3,000.0 | (76) | 429.56 |
| (-60) | 419,380 | (-17) | 24,486 | (26) | 2,871.6 | (77) | 415.61 |
| (-59) | 388,572 | (-16) | 23,136 | (27) | 2,749.4 | (78) | 402.20 |
| (-58) | 360,219 | (-15) | 21,868 | (28) | 2,633.1 | (79) | 389.29 |
| (-57) | 334,123 | (-14) | 20,678 | (29) | 2,522.3 | (80) | 376.85 |
| (-56) | 310,086 | (-13) | 19,559 | (30) | 2,416.8 | (81) | 364.87 |
| (-55) | 287,937 | (-12) | 18,508 | (31) | 2,316.3 | (82) | 353.33 |
| (-54) | 267,507 | (-11) | 17,519 | (32) | 2,220.5 | (83) | 342.21 |
| (-53) | 248,660 | (-10) | 16,589 | (33) | 2,129.2 | (84) | 331.50 |
| (-52) | 231,264 | (-9) | 15,714 | (34) | 2,042.1 | (85) | 321.17 |
| (-51) | 215,193 | (-8) | 14,890 | (35) | 1,959.0 | (86) | 311.22 |
| (-50) | 200,348 | (-7) | 14,114 | (36) | 1,879.8 | (87) | 301.62 |
| (-49) | 186,617 | (-6) | 13,383 | (37) | 1,804.3 | (88) | 292.37 |
| (-48) | 173,916 | (-5) | 12,694 | (38) | 1,732.1 | (89) | 283.44 |
| (-47) | 162,159 | (-4) | 12,044 | (39) | 1,663.2 | (90) | 274.83 |
| (-46) | 151,269 | (-3) | 11,432 | (40) | 1,597.5 | (91) | 266.52 |
| (-45) | 141,183 | (-2) | 10,854 | (41) | 1,534.7 | (92) | 258.51 |
| (-44) | 131,833 | (-1) | 10,309 | (42) | 1,474.6 | (93) | 250.78 |
| (-43) | 123,160 | (0) | 9,795.2 | (43) | 1,417.3 | (94) | 243.31 |
| (-42) | 115,114 | (1) | 9,309.1 | (44) | 1,362.5 | (95) | 236.10 |
| (-41) | 107,642 | (2) | 8,850.0 | (45) | 1,310.0 | (96) | 229.14 |
| (-40) | 100,701 | (3) | 8,416.3 | (46) | 1,259.9 | (97) | 222.41 |
| (-39) | 94,254 | (4) | 8,006.3 | (47) | 1,212.0 | (98) | 215.92 |
| (-38) | 88,258 | (5) | 7,618.7 | (48) | 1,166.1 | (99) | 209.65 |

CONTINUED 

Application Guide

Reference Data

RTD Resistance vs. Temperature Tables

Standard Thermistors

Continued

No. 12—3000 Ohms—Ref. 52 cont.

| Temp (°C) | R Value Ohms | Temp. (°C) | R Value Ohms | Temp. (°C) | R Value Ohms | Temp. (°C) | R Value Ohms |
|-----------|--------------|------------|--------------|------------|--------------|------------|--------------|
| (100) | 203.59 | (113) | 140.83 | (126) | 99.634 | (139) | 71.947 |
| (101) | 197.73 | (114) | 137.03 | (127) | 97.100 | (140) | 70.225 |
| (102) | 192.07 | (115) | 133.34 | (128) | 94.644 | (141) | 68.550 |
| (103) | 186.60 | (116) | 129.77 | (129) | 99.260 | (142) | 66.923 |
| (104) | 181.31 | (117) | 126.31 | (130) | 89.946 | (143) | 65.341 |
| (105) | 176.19 | (118) | 122.96 | (131) | 87.703 | (144) | 63.804 |
| (106) | 171.24 | (119) | 119.72 | (132) | 85.524 | (145) | 62.309 |
| (107) | 166.46 | (120) | 116.57 | (133) | 83.410 | (146) | 60.857 |
| (108) | 161.83 | (121) | 113.53 | (134) | 81.356 | (147) | 59.445 |
| (109) | 157.35 | (122) | 110.57 | (135) | 79.363 | (148) | 58.071 |
| (110) | 153.02 | (123) | 107.71 | (136) | 77.427 | (149) | 56.735 |
| (111) | 148.82 | (124) | 104.93 | (137) | 75.547 | (150) | 55.436 |
| (112) | 144.77 | (125) | 102.24 | (138) | 73.721 | | |

No. 16—100,000 Ohms—Ref. 53

| Temp (°C) | R Value Ohms | Temp. (°C) | R Value Ohms | Temp. (°C) | R Value Ohms | Temp. (°C) | R Value Ohms |
|-----------|--------------|------------|--------------|------------|--------------|------------|--------------|
| (-60) | 17,400,000 | (-36) | 3,061,000 | (-12) | 686,400 | (12) | 188,100 |
| (-59) | 16,093,000 | (-35) | 2,862,000 | (-11) | 648,000 | (13) | 179,000 |
| (-58) | 14,892,000 | (-34) | 2,678,000 | (-10) | 612,000 | (14) | 170,300 |
| (-57) | 13,788,000 | (-33) | 2,506,000 | (-9) | 578,000 | (15) | 162,100 |
| (-56) | 12,773,000 | (-32) | 2,347,000 | (-8) | 546,100 | (16) | 154,300 |
| (-55) | 11,839,000 | (-31) | 2,198,000 | (-7) | 516,100 | (17) | 146,900 |
| (-54) | 10,979,000 | (-30) | 2,060,000 | (-6) | 488,000 | (18) | 139,900 |
| (-53) | 10,186,000 | (-29) | 1,931,000 | (-5) | 461,500 | (19) | 133,300 |
| (-52) | 9,455,001 | (-28) | 1,811,000 | (-4) | 436,600 | (20) | 127,000 |
| (-51) | 8,782,000 | (-27) | 1,699,000 | (-3) | 413,200 | (21) | 121,000 |
| (-50) | 8,160,000 | (-26) | 1,594,000 | (-2) | 391,200 | (22) | 115,300 |
| (-49) | 7,587,999 | (-25) | 1,497,000 | (-1) | 370,500 | (23) | 109,900 |
| (-48) | 7,059,001 | (-24) | 1,407,000 | (0) | 351,000 | (24) | 104,800 |
| (-47) | 6,570,000 | (-23) | 1,322,000 | (1) | 332,600 | (25) | 100,000 |
| (-46) | 6,117,000 | (-22) | 1,243,000 | (2) | 315,300 | (26) | 95,440 |
| (-45) | 5,698,000 | (-21) | 1,169,000 | (3) | 299,000 | (27) | 91,120 |
| (-44) | 5,310,000 | (-20) | 1,100,000 | (4) | 283,600 | (28) | 87,010 |
| (-43) | 4,950,000 | (-19) | 1,036,000 | (5) | 269,100 | (29) | 83,110 |
| (-42) | 4,616,000 | (-18) | 975,800 | (6) | 255,500 | (30) | 79,400 |
| (-41) | 4,307,000 | (-17) | 919,500 | (7) | 242,600 | (31) | 75,870 |
| (-40) | 4,020,000 | (-16) | 866,700 | (8) | 230,400 | (32) | 72,520 |
| (-39) | 3,753,000 | (-15) | 817,300 | (9) | 218,900 | (33) | 69,330 |
| (-38) | 3,505,000 | (-14) | 770,800 | (10) | 208,000 | (34) | 66,300 |
| (-37) | 3,274,000 | (-13) | 727,300 | (11) | 197,800 | (35) | 63,420 |

Temperature Sensors

CONTINUED

Application Guide

Reference Data

RTD Resistance vs. Temperature Tables

Standard Thermistors

Continued

No. 16—100,000 Ohms—Ref. 53 cont.

| Temp (°C) | R Value Ohms | Temp. (°C) | R Value Ohms | Temp. (°C) | R Value Ohms | Temp. (°C) | R Value Ohms |
|-----------|--------------|------------|--------------|------------|--------------|------------|--------------|
| (36) | 60,690 | (80) | 10,800 | (124) | 2,695 | (168) | 866.3 |
| (37) | 58,080 | (81) | 10,430 | (125) | 2,620 | (169) | 846.3 |
| (38) | 55,600 | (82) | 10,070 | (126) | 2,548 | (170) | 826.8 |
| (39) | 53,250 | (83) | 9,731 | (127) | 2,478 | (171) | 807.9 |
| (40) | 51,000 | (84) | 9,402 | (128) | 2,410 | (172) | 789.5 |
| (41) | 48,870 | (85) | 9,086 | (129) | 2,344 | (173) | 771.5 |
| (42) | 46,830 | (86) | 8,782 | (130) | 2,280 | (174) | 754.1 |
| (43) | 44,900 | (87) | 8,489 | (131) | 2,218 | (175) | 737.1 |
| (44) | 43,050 | (88) | 8,208 | (132) | 2,158 | (176) | 720.6 |
| (45) | 41,280 | (89) | 7,937 | (133) | 2,099 | (177) | 704.5 |
| (46) | 39,600 | (90) | 7,676 | (134) | 2,043 | (178) | 688.8 |
| (47) | 38,000 | (91) | 7,425 | (135) | 1,988 | (179) | 673.6 |
| (48) | 36,460 | (92) | 7,183 | (136) | 1,935 | (180) | 658.7 |
| (49) | 35,000 | (93) | 6,951 | (137) | 1,884 | (181) | 644.2 |
| (50) | 33,600 | (94) | 6,727 | (138) | 1,834 | (182) | 630.1 |
| (51) | 32,260 | (95) | 6,511 | (139) | 1,786 | (183) | 616.4 |
| (52) | 30,990 | (96) | 6,303 | (140) | 1,739 | (184) | 603.0 |
| (53) | 29,770 | (97) | 6,103 | (141) | 1,694 | (185) | 590.0 |
| (54) | 28,600 | (98) | 5,909 | (142) | 1,650 | (186) | 577.3 |
| (55) | 27,490 | (99) | 5,723 | (143) | 1,607 | (187) | 564.9 |
| (56) | 26,420 | (100) | 5,544 | (144) | 1,566 | (188) | 552.8 |
| (57) | 25,400 | (101) | 5,371 | (145) | 1,526 | (189) | 541.0 |
| (58) | 24,430 | (102) | 5,204 | (146) | 1,487 | (190) | 529.6 |
| (59) | 23,490 | (103) | 5,043 | (147) | 1,450 | (191) | 518.4 |
| (60) | 22,600 | (104) | 4,888 | (148) | 1,413 | (192) | 507.5 |
| (61) | 21,750 | (105) | 4,739 | (149) | 1,377 | (193) | 496.9 |
| (62) | 20,930 | (106) | 4,594 | (150) | 1,343 | (194) | 486.5 |
| (63) | 20,150 | (107) | 4,455 | (151) | 1,309 | (195) | 476.4 |
| (64) | 19,400 | (108) | 4,320 | (152) | 1,277 | (196) | 466.6 |
| (65) | 18,680 | (109) | 4,190 | (153) | 1,245 | (197) | 457.0 |
| (66) | 17,990 | (110) | 4,065 | (154) | 1,215 | (198) | 447.6 |
| (67) | 17,330 | (111) | 3,944 | (155) | 1,185 | (199) | 438.4 |
| (68) | 16,690 | (112) | 3,827 | (156) | 1,156 | (200) | 429.5 |
| (69) | 16,080 | (113) | 3,714 | (157) | 1,128 | (201) | 420.8 |
| (70) | 15,500 | (114) | 3,605 | (158) | 1,100 | (202) | 412.3 |
| (71) | 14,940 | (115) | 3,500 | (159) | 1,074 | (203) | 404.0 |
| (72) | 14,400 | (116) | 3,398 | (160) | 1,048 | (204) | 395.9 |
| (73) | 13,880 | (117) | 3,299 | (161) | 1,023 | (205) | 388.0 |
| (74) | 13,380 | (118) | 3,204 | (162) | 998.7 | (206) | 380.3 |
| (75) | 12,900 | (119) | 3,112 | (163) | 975.0 | (207) | 372.7 |
| (76) | 12,450 | (120) | 3,023 | (164) | 952.0 | (208) | 365.4 |
| (77) | 12,010 | (121) | 2,937 | (165) | 929.7 | (209) | 358.2 |
| (78) | 11,590 | (122) | 2,853 | (166) | 908.0 | (210) | 351.2 |
| (79) | 11,190 | (123) | 2,773 | (167) | 886.8 | (211) | 344.3 |

CONTINUED 

Application Guide

Reference Data

RTD Resistance vs. Temperature Tables

Standard Thermistors

Continued

No. 16—100,000 Ohms—Ref. 53 cont.

| Temp (°C) | R Value Ohms | Temp. (°C) | R Value Ohms | Temp. (°C) | R Value Ohms | Temp. (°C) | R Value Ohms |
|-----------|--------------|------------|--------------|------------|--------------|------------|--------------|
| (212) | 337.7 | (234) | 223.4 | (256) | 152.7 | (278) | 107.5 |
| (213) | 331.1 | (235) | 219.5 | (257) | 150.2 | (279) | 105.9 |
| (214) | 324.7 | (236) | 215.6 | (258) | 147.8 | (280) | 104.3 |
| (215) | 318.5 | (237) | 211.7 | (259) | 145.4 | (281) | 102.7 |
| (216) | 312.4 | (238) | 208.0 | (260) | 143.0 | (282) | 101.2 |
| (217) | 306.5 | (239) | 204.4 | (261) | 140.7 | (283) | 99.70 |
| (218) | 300.6 | (240) | 200.8 | (262) | 138.4 | (284) | 98.20 |
| (219) | 295.0 | (241) | 197.3 | (263) | 136.2 | (285) | 96.70 |
| (220) | 289.4 | (242) | 193.9 | (264) | 134.0 | (286) | 95.30 |
| (221) | 284.0 | (243) | 190.5 | (265) | 131.9 | (287) | 93.90 |
| (222) | 278.7 | (244) | 187.2 | (266) | 129.8 | (288) | 92.50 |
| (223) | 273.5 | (245) | 184.0 | (267) | 127.7 | (289) | 91.10 |
| (224) | 268.4 | (246) | 180.9 | (268) | 125.7 | (290) | 89.80 |
| (225) | 263.4 | (247) | 177.8 | (269) | 123.7 | (291) | 88.50 |
| (226) | 258.6 | (248) | 174.8 | (270) | 121.8 | (292) | 87.20 |
| (227) | 253.8 | (249) | 171.8 | (271) | 119.9 | (293) | 86.00 |
| (228) | 249.2 | (250) | 168.9 | (272) | 118.0 | (294) | 84.70 |
| (229) | 244.7 | (251) | 166.1 | (273) | 116.2 | (295) | 83.50 |
| (230) | 240.2 | (252) | 163.3 | (274) | 114.4 | (296) | 82.30 |
| (231) | 235.9 | (253) | 160.6 | (275) | 112.6 | (297) | 81.10 |
| (232) | 231.6 | (254) | 157.9 | (276) | 110.9 | (298) | 80.00 |
| (233) | 227.5 | (255) | 155.3 | (277) | 109.2 | (299) | 78.80 |
| | | | | | | (300) | 77.70 |

Temperature Sensors

Application Guide

Reference Data

RTD Resistance vs. Temperature Tables

DIN Platinum RTDs

Resistance vs. Temperature for IEC 60751 100 Ohm Platinum RTDs with Temperature Coefficient of 0.00385—Ref. 54

| (°C) | 0 | -1 | -2 | -3 | -4 | -5 | -6 | -7 | -8 | -9 |
|--------|--------|-------|-------|-------|-------|-------|-------|-------|-------|-------|
| (-200) | 18.49 | — | — | — | — | — | — | — | — | — |
| (-190) | 22.80 | 22.37 | 21.94 | 21.51 | 21.08 | 20.65 | 20.22 | 19.79 | 19.36 | 18.93 |
| (-180) | 27.08 | 26.65 | 26.23 | 25.80 | 25.37 | 24.94 | 24.52 | 24.09 | 23.66 | 23.23 |
| (-170) | 31.32 | 30.90 | 30.47 | 30.05 | 29.63 | 29.20 | 28.78 | 28.35 | 27.93 | 27.50 |
| (-160) | 35.53 | 35.11 | 34.69 | 34.27 | 33.85 | 33.43 | 33.01 | 32.59 | 32.16 | 31.74 |
| (-150) | 39.71 | 39.30 | 38.88 | 38.46 | 38.04 | 37.63 | 37.21 | 36.79 | 36.37 | 35.95 |
| (-140) | 43.87 | 43.45 | 43.04 | 42.63 | 42.21 | 41.79 | 41.38 | 40.96 | 40.55 | 40.13 |
| (-130) | 48.00 | 47.59 | 47.18 | 46.76 | 46.35 | 45.94 | 45.52 | 45.11 | 44.70 | 44.28 |
| (-120) | 52.11 | 51.70 | 51.29 | 50.88 | 50.47 | 50.06 | 49.64 | 49.23 | 48.82 | 48.41 |
| (-110) | 56.19 | 55.78 | 55.38 | 54.97 | 54.56 | 54.15 | 53.74 | 53.33 | 52.92 | 52.52 |
| (-100) | 60.52 | 59.85 | 59.44 | 59.04 | 58.63 | 58.22 | 57.82 | 57.41 | 57.00 | 56.60 |
| (-90) | 64.30 | 63.90 | 63.49 | 63.09 | 62.68 | 62.28 | 61.87 | 61.47 | 61.06 | 60.66 |
| (-80) | 68.33 | 67.92 | 67.52 | 67.12 | 66.72 | 66.31 | 65.91 | 65.51 | 65.11 | 64.70 |
| (-70) | 72.33 | 71.93 | 71.53 | 71.13 | 70.73 | 70.33 | 69.93 | 69.53 | 69.13 | 68.73 |
| (-60) | 76.33 | 75.93 | 75.53 | 75.13 | 74.73 | 74.33 | 73.93 | 73.53 | 73.13 | 72.73 |
| (-50) | 80.31 | 79.91 | 79.51 | 79.11 | 78.72 | 78.32 | 77.92 | 77.52 | 77.13 | 76.73 |
| (-40) | 84.27 | 83.88 | 83.48 | 83.08 | 82.69 | 82.29 | 81.89 | 81.50 | 81.10 | 80.70 |
| (-30) | 88.22 | 87.83 | 87.43 | 87.04 | 86.64 | 86.25 | 85.85 | 85.46 | 85.06 | 84.67 |
| (-20) | 92.16 | 91.77 | 91.37 | 90.98 | 90.59 | 90.19 | 89.80 | 89.40 | 89.01 | 88.62 |
| (-10) | 96.09 | 95.69 | 95.30 | 94.91 | 94.52 | 94.12 | 93.73 | 93.34 | 92.95 | 92.55 |
| (0) | 100.00 | 99.61 | 99.22 | 98.83 | 98.44 | 98.04 | 97.65 | 97.26 | 96.87 | 96.48 |

CONTINUED 

Application Guide

Reference Data

RTD Resistance vs. Temperature Tables

DIN Platinum RTDs

Resistance vs. Temperature for IEC 60751 100 Ohm Platinum RTDs with Temperature Coefficient of 0.00385—Ref. 54, cont.

| (°C) | 0 | 1 | 2 | 3 | 4 | 5 | 6 | 7 | 8 | 9 |
|-------|--------|--------|--------|--------|--------|--------|--------|--------|--------|--------|
| (0) | 100.00 | 100.39 | 100.78 | 101.17 | 101.56 | 101.95 | 102.34 | 102.73 | 103.12 | 103.51 |
| (10) | 103.90 | 104.29 | 104.68 | 105.07 | 105.46 | 105.85 | 106.24 | 106.63 | 107.02 | 107.40 |
| (20) | 107.79 | 108.18 | 108.57 | 108.96 | 109.35 | 109.73 | 110.12 | 110.51 | 110.90 | 111.28 |
| (30) | 111.67 | 112.06 | 112.45 | 112.83 | 113.22 | 113.61 | 113.99 | 114.38 | 114.77 | 115.15 |
| (40) | 115.54 | 115.93 | 116.31 | 116.70 | 117.08 | 117.47 | 117.85 | 118.24 | 118.62 | 119.01 |
| (50) | 119.40 | 119.78 | 120.16 | 120.55 | 120.93 | 121.32 | 121.70 | 122.09 | 122.47 | 122.86 |
| (60) | 123.24 | 123.62 | 124.01 | 124.39 | 124.77 | 125.16 | 125.54 | 125.92 | 126.31 | 126.69 |
| (70) | 127.07 | 127.45 | 127.84 | 128.22 | 128.60 | 128.98 | 129.37 | 129.75 | 130.13 | 130.51 |
| (80) | 130.89 | 131.27 | 131.66 | 132.04 | 132.42 | 132.80 | 133.18 | 133.56 | 133.94 | 134.32 |
| (90) | 134.70 | 135.08 | 135.46 | 135.84 | 136.22 | 136.60 | 136.98 | 137.36 | 137.74 | 138.12 |
| (100) | 138.50 | 138.88 | 139.26 | 139.64 | 140.02 | 140.39 | 140.77 | 141.15 | 141.53 | 141.91 |
| (110) | 142.29 | 142.66 | 143.04 | 143.42 | 143.80 | 144.17 | 144.55 | 144.93 | 145.31 | 145.68 |
| (120) | 146.06 | 146.44 | 146.81 | 147.19 | 147.57 | 147.94 | 148.32 | 148.70 | 149.07 | 149.45 |
| (130) | 149.82 | 150.20 | 150.57 | 150.95 | 151.33 | 151.70 | 152.08 | 152.45 | 152.83 | 153.20 |
| (140) | 153.58 | 153.95 | 154.32 | 154.70 | 155.07 | 155.45 | 155.82 | 156.19 | 156.57 | 156.94 |
| (150) | 157.31 | 157.69 | 158.06 | 158.43 | 158.81 | 159.18 | 159.55 | 159.93 | 160.30 | 160.67 |
| (160) | 161.04 | 161.42 | 161.79 | 162.16 | 162.53 | 162.90 | 163.27 | 163.65 | 164.02 | 164.39 |
| (170) | 164.76 | 165.13 | 165.50 | 165.87 | 166.24 | 166.61 | 166.98 | 167.35 | 167.72 | 168.09 |
| (180) | 168.46 | 168.83 | 169.20 | 169.57 | 169.94 | 170.31 | 170.68 | 171.05 | 171.42 | 171.79 |
| (190) | 172.16 | 172.53 | 172.90 | 173.26 | 173.63 | 174.00 | 174.37 | 174.74 | 175.10 | 175.47 |

Temperature Sensors

CONTINUED

Application Guide

Reference Data

RTD Resistance vs. Temperature Tables

DIN Platinum RTDs

Resistance vs. Temperature for IEC 60751 100 Ohm Platinum RTDs with Temperature Coefficient of 0.00385—Ref. 54, cont.

| (°C) | 0 | 1 | 2 | 3 | 4 | 5 | 6 | 7 | 8 | 9 |
|-------|--------|--------|--------|--------|--------|--------|--------|--------|--------|--------|
| (200) | 175.84 | 176.21 | 176.57 | 176.94 | 177.31 | 177.68 | 178.04 | 178.41 | 178.78 | 179.14 |
| (210) | 179.51 | 179.88 | 180.24 | 180.61 | 180.97 | 181.34 | 181.71 | 182.07 | 182.44 | 182.80 |
| (220) | 183.17 | 183.53 | 183.90 | 184.26 | 184.63 | 184.99 | 185.36 | 185.72 | 186.09 | 186.45 |
| (230) | 186.82 | 187.18 | 187.54 | 187.91 | 188.27 | 188.63 | 189.00 | 189.36 | 189.72 | 190.09 |
| (240) | 190.45 | 190.81 | 191.18 | 191.54 | 191.90 | 192.26 | 192.63 | 192.99 | 193.35 | 193.71 |
| (250) | 194.07 | 194.44 | 194.80 | 195.16 | 195.52 | 195.88 | 196.24 | 196.60 | 196.96 | 197.33 |
| (260) | 197.69 | 198.05 | 198.41 | 198.77 | 199.13 | 199.49 | 199.85 | 200.21 | 200.57 | 200.93 |
| (270) | 201.29 | 201.65 | 202.01 | 202.36 | 202.72 | 203.08 | 203.44 | 203.80 | 204.16 | 204.52 |
| (280) | 204.88 | 205.23 | 205.59 | 205.95 | 206.31 | 206.67 | 207.02 | 207.38 | 207.74 | 208.10 |
| (290) | 208.45 | 208.81 | 209.17 | 209.52 | 209.88 | 210.24 | 210.59 | 210.95 | 211.31 | 211.66 |
| (300) | 212.02 | 212.37 | 212.73 | 213.09 | 213.44 | 213.80 | 214.15 | 214.51 | 214.86 | 215.22 |
| (310) | 215.57 | 215.93 | 216.28 | 216.64 | 216.99 | 217.35 | 217.70 | 218.05 | 218.41 | 218.76 |
| (320) | 219.12 | 219.47 | 219.82 | 220.18 | 220.53 | 220.88 | 221.24 | 221.59 | 221.94 | 222.29 |
| (330) | 222.65 | 223.00 | 223.35 | 223.70 | 224.06 | 224.41 | 224.76 | 225.11 | 225.46 | 225.81 |
| (340) | 226.17 | 226.52 | 226.87 | 227.22 | 227.57 | 227.92 | 228.27 | 228.62 | 228.97 | 229.32 |
| (350) | 229.67 | 230.02 | 230.37 | 230.72 | 231.07 | 231.42 | 231.77 | 232.12 | 232.47 | 232.82 |
| (360) | 233.17 | 233.52 | 233.87 | 234.22 | 234.56 | 234.91 | 235.26 | 235.61 | 235.96 | 236.31 |
| (370) | 236.65 | 237.00 | 237.35 | 237.70 | 238.04 | 238.39 | 238.74 | 239.09 | 239.43 | 239.78 |
| (380) | 240.13 | 240.47 | 240.82 | 241.17 | 241.51 | 241.86 | 242.20 | 242.55 | 242.90 | 243.24 |
| (390) | 243.59 | 243.93 | 244.28 | 244.62 | 244.97 | 245.31 | 245.66 | 246.00 | 246.35 | 246.69 |

Application Guide

Temperature Controllers

This section of the Application Guide is devoted to temperature controllers, their types, styles, methods of use and general considerations for determining applications. If you're unable to find or determine which type or model of temperature controller will best suit your needs, call your nearest Watlow Representative. Sales offices are listed on [pages four-six](#).

Generally speaking, a temperature controller receives an input signal from a temperature sensor, compares that signal to a preset value and then produces an output signal.

Watlow manufactures a wide variety of user-oriented temperature controllers. Each is designed with our philosophy of Control Confidence® to help ensure trouble-free, reliable operation in the most hostile industrial environments. Available in standard DIN sizes, they lend themselves readily to design considerations or replacement of existing temperature controllers. The full line of Watlow controllers include ramping controllers, microprocessor based digital controllers, digital indicators, non-indicating controllers and alarms and limits. For specific information on each control model, see Watlow's controller catalog, *Watlow Temperature and Power Controllers*.



Thermal System Components

To understand the principles of regulating process temperature, let's examine the components of the thermal system. They include the **work load**, the **heat source**, the **heat transfer medium** and the **temperature controlling device(s)**.

The **work load** is that which must be heated or cooled.

The **heat source** is the device which delivers heat to the system.

The **heat transfer medium** is the material (a solid, liquid or gas) through which the heat flows from the heat source to the work.

The **temperature controlling device** directs its output to add, subtract, or maintain heat by switching heaters or cooling apparatus on and off. The controlling system usually includes sensory feedback.

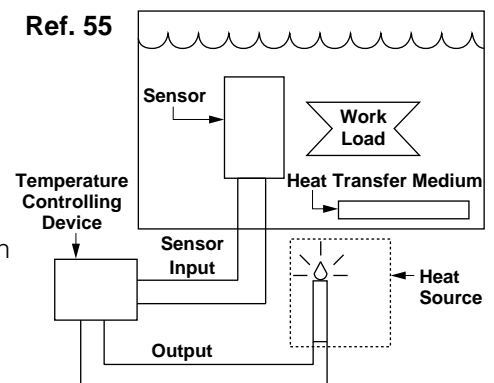

Application Guide

Temperature Controllers

Product Overview

Controllers

Single-Loop Auto-tuning

Available in 1/32, 1/16, 1/8 and 1/4 DIN sizes, agency approved Watlow single-loop, auto-tuning temperature controllers automatically set PID control parameters for optimum system performance. Manual settings also permit on-off, P, PI or PID control modes. All Watlow auto-tuning controllers are designed and manufactured to withstand harsh industrial environments and come with a three-year warranty for Control Confidence®.



Applications

- Batch process
- Electroplating
- Environmental chambers
- Foodservice equipment
- Furnace / ovens
- Medical and dental equipment
- Packaging
- Plastics processing
- Pulp and paper
- Semiconductor manufacturing

SERIES SD

- 1/32 to 1/4 DIN size
- ±0.10 percent accuracy
- Operating environment from 0 to 65°C (32 to 150°F)

SERIES 96

- 1/16 DIN size
- ±0.10 percent accuracy
- Operating environment from 0 to 65°C (32 to 150°F)

SERIES 988/989

- 1/8 DIN size
- ±0.10 percent accuracy
- Operating environment from 0 to 65°C (32 to 150°F)

SERIES V4

- 1/4 DIN size
- ±0.10 percent accuracy
- Operating environment from 0 to 65°C (32 to 150°F)

SERIES F4P

- 1/4 DIN size
- ±0.10 percent accuracy
- Operating environment from 0 to 65°C (32 to 150°F)

SERIES PD

- DIN Rail
- ±0.10 percent accuracy
- Operating environment from 0 to 65°C (32 to 150°F)

Application Guide

Temperature Controllers

Product Overview

Continued

Basic

Watlow's agency approved basic temperature controllers are compact and offer an economical cost effective control solution for less demanding applications requiring basic on-off control. Reliability is further enhanced with either a NEMA 4X front panel or totally enclosed electronics. All Watlow basic controllers are designed and manufactured to withstand harsh industrial environments, and come with a three-year warranty for Control Confidence®.



Applications

- Foodservice equipment
- General process control
- Percent power, open loop control
- Plastics and textile processing
- Heat or cool control
- HVAC

SERIES CF

- Open board, DIN Rail or 1/8 DIN Square
- ±1.00 percent accuracy
- Operating environment from 0 to 55°C (32 to 131°F)

SERIES CV

- Open board, DIN Rail or 1/8 DIN Square
- ±1.00 percent accuracy
- Operating environment from 0 to 55°C (32 to 131°F)

SERIES 101

- ±1.00 percent accuracy
- Operating environment from 0 to 55°C (32 to 131°F)

SERIES 102

- 1/6 DIN size
- ±1.00 percent accuracy
- Operating environment from 0 to 55°C (32 to 131°F)

SERIES 103

- DIN rail mount
- ±1.00 percent accuracy
- Operating environment from 0 to 55°C (32 to 131°F)

SERIES 104

- Open board
- ±1.00 percent accuracy
- Operating environment from 0 to 55°C (32 to 131°F)

Application Guide

Temperature Controllers

Product Overview

Continued

Time/Temperature Profiling

Ideal for applications that change temperature over time, Watlow's agency approved time/temperature profiling (ramping) controllers set new standards of performance. PID auto-tuning makes setup easy. All are available with a broad range of industry standard I/O and communication options. All Watlow time/temperature profiling controllers are designed and manufactured to withstand harsh industrial environments, and come with a three-year warranty for Control Confidence®.



Applications

- Environmental chambers
- Complex process furnaces
- Any process that changes variables over time
- Semiconductor manufacturing
- Processes needing data logging
- Processes requiring slidewire control of valves or positions

SERIES SD

- 1/32 to 1/4 DIN size
- ±0.10 percent accuracy
- Operating environment from 0 to 65°C (32 to 150°F)

SERIES 96

- 1/16 DIN size
- ±0.10 percent accuracy
- Operating environment from 0 to 65°C (32 to 150°F)

SERIES 981/982

- 1/8 DIN size
- ±0.10 percent accuracy
- Operating environment from 0 to 55°C (32 to 130°F)

SERIES F4S

- 1/4 DIN size
- ±0.10 percent accuracy
- Operating environment from 0 to 55°C (32 to 130°F)

SERIES F4D

- 1/4 DIN size
- ±0.10 percent accuracy
- Operating environment from 0 to 55°C (32 to 130°F)

Application Guide

Temperature Controllers

Product Overview

Continued

Limits and Alarms

Watlow limit controllers provide agency approved performance in safety limit applications, including UL®, CSA, A.G.A. and FM (on some models). All are available with industry standard I/O options. All Watlow limit/alarm controllers are designed and manufactured to withstand harsh industrial environments, and come with a three-year warranty for Control Confidence®.



Applications

- High and low safety limit control
- Environmental chambers
- Furnace / ovens
- Semiconductor
- Boiler

SERIES LF

- Open Board, DIN Rail or 1/8 DIN Square
- ±1.00 percent accuracy
- Operating environment from 0 to 565°C (32 to 131°F)

SERIES LV

- Open Board, DIN Rail or 1/8 DIN Square
- ±1.00 percent accuracy
- Operating environment from 0 to 565°C (32 to 131°F)

SERIES SD

- 1/32 to 1/4 DIN size
- ±0.10 percent accuracy
- Operating environment from 0 to 65°C (32 to 150°F)

SERIES 97

- 1/16 DIN size
- ±0.10 percent accuracy
- Operating environment from 0 to 65°C (32 to 150°F)

SERIES 142

- ±1.00 percent accuracy
- Operating environment from 0 to 55°C (32 to 131°F)

SERIES 145

- 1/16 DIN size
- ±1.00 percent accuracy
- Operating environment from 0 to 55°C (32 to 131°F)

SERIES 146

- DIN rail mount
- ±1.00 percent accuracy
- Operating environment from 0 to 55°C (32 to 131°F)

SERIES 147

- Open board
- ±1.00 percent accuracy
- Operating environment from 0 to 55°C (32 to 131°F)

SERIES TLM-8

- Sub-panel or DIN rail
- 5 percent accuracy
- Operating environment from 0 to 60°C (32 to 140°F)

Application Guide

Temperature Controllers

Product Overview

Continued

Multi-Loop

2-Loop

Agency approved Watlow two-loop, auto-tuning temperature controllers automatically set PID control parameters for optimum system performance. Manual settings also permit on-off, P, PI, or PID control modes. Data communications or remote operation or data logging. All are available with a broad range of industry standard I/O options. All Watlow two-loop controllers are designed and manufactured to withstand harsh industrial environments, and come with a three-year warranty for Control Confidence®.



SERIES PD

- DIN Rail
- 0.10 percent
- 0 to 65°C (32 to 150°F)

SERIES 733/734

- 0.10 percent at 25°C accuracy

SERIES 998/999

- ½ DIN size
- 0.10 percent at 25°C accuracy

SERIES F4D

- ¼ DIN size
- 0.10 percent at 25°C accuracy

MINICHEF®

- 3¼ x 2 DIN size
- 0.20 percent for Type J T/C and RTD at 25°C
- 0.35 percent for Types K and E T/C at 25°C

Applications

- Any process requiring two control loops
- Foodservice equipment
- Complex process furnaces
- Environmental chambers
- Processes requiring control / monitoring from a computer

Application Guide

Temperature Controllers

Product Overview

Continued

4- to 48-Loop

With up to 48 control loops, Watlow Anafaze PID controllers deliver the options and performance demanded by complex process applications. Each controller offers a wide range of I/O options with exceptional accuracy. Inputs can be multiple and mixed, including thermocouple, RTD and process.

Multiple job/recipe storage makes batch setups fast. Auto-tuning PID control sets optimum control parameters. Versatile alarms and serial communications round out the features. In addition, the PPC-2000 and CPC400 controllers gives users the ability to add ladder-logic programs to the PID control. The SERIES D8 controller offers DeviceNet communications in four and eight loop models. Optional Windows®-based software permits remote operation and monitoring with standard Windows® operating systems. Three-year warranty.



4-Loop

CLS204, CPC404, SERIES D8

- ½ DIN size
- 0.07 percent at 25°C accuracy
- 0.17 second channel scan time

8-Loop

CLS208, CLS408, SERIES D8

- ½ DIN size
- 0.07 percent at 25°C accuracy
- 0.17 to 0.33 second channel scan time

16-Loop

CLS216, MLS316

- ½ DIN size
- 0.07 percent at 25°C accuracy
- 0.67 second channel scan time

32-Loop

MLS332

- ½ DIN size
- 0.07 percent at 25°C accuracy
- 1.33 second channel scan time

4- to 48-Loop

PPC-2000

- Panel or DIN rail mountable
- 0.1 percent at 25°C accuracy
- 0.14 second channel scan time (4 channel module)

MINICHEF 4000

- Panel or DIN rail mountable
- 0.05 percent at 25°C accuracy
- 1.00 second channel scan time

Alarm Scanner and Data Logger

16-Channel CAS200

- ½ DIN size
- 0.07 percent at 25°C accuracy
- 0.67 second channel scan time

8-Channel TLM8

- Panel or DIN rail mountable

SERIES D8

- ½ DIN size
- 0.07 percent at 25°C accuracy
- 0.17 second channel scan time

Applications

- Electronics
- Plastics
- Rubber
- Textiles
- Packaging applications
- Metals
- Paper industry
- Automotive
- Chemical
- Sealing
- Foodservice
- Semiconductor equipment

Application Guide

Temperature Controllers

Product Overview

Continued

Control Panels and Boxes

Watlow control panels and boxes are convenient, ready-to-connect packages that utilize temperature controllers, power controllers, multi-loop controllers and related safety limit controllers in NEMA-rated enclosures. Control panels and boxes can be designed to meet your particular application. Controller options include auto-tune, PID, on-off and percent power. Industry standard I/O options meet virtually all applications. Agency approved temperature, limit and power controllers mean built-in reliability. Enclosure NEMA ratings meet application environments. Solid state power controllers available in single-phase, and three-phase/two and three leg configurations with phase angle or burst fire switching. Control boxes are available in ratings up to 50 amps, while standard control panels are available in ratings up to 300 amps. Custom control panels are available up to 1600 amps or more may be available upon request. UL® 508 panel listings and CE certifications are also available.



Applications

- System applications requiring agency approved controllers
- Applications requiring specific NEMA rated enclosures
- Applications requiring easy controller package installation

Features

- Designed per UL®508 and NEC standards
- Complete I & M documentation with component manuals and CAD circuit drawings
- Enclosure cooling with fans, vortex coolers or air conditioners
- Circuit protection with fuses or circuit breakers
- Ground fault protection
- Real-time data acquisition for process validation

Application Guide

Temperature Controllers

Thermal Control Principles

The selection of a temperature controller is determined first of all by the degree of controllability required. It's best to select the temperature controller type and model that gives you the optimum control you need to achieve desired results. You'll want to avoid selecting more control than is required. Doing so will only add needless expense and complexity to your heating system.

Control Accuracy

What is Accuracy?

Accuracy is a measure of controller capability alone, exclusive of external factors. It is usually expressed in terms of percent of span. (Span is the algebraic difference between the upper and lower input range values.)

Accuracy is the limit of error which the controller can introduce into the control loop across the entire span. Be careful, there is a great difference between specified controller accuracies and the overall accuracy of your thermal system.

System accuracy is extremely sensitive to the overall system design. It must be a major factor in the planning stage of a system. Accuracy is influenced by the size of the system's heating source, system heat transfer delays, type of sensor and its location, type of controller modes selected, noise in the system, and other factors.

We provide you with controller accuracy specifications to help you select system components for the overall system accuracy you need. Accuracy specifications are stated in conjunction with parameters whose values determine the characteristics of the

controller's accuracy. Common accuracy parameters are input voltages and frequency, ambient temperature conditions, and so forth.

Standard categories of accuracy ratings are:

Calibration Accuracy

Calibration accuracy refers to the amount of error between the temperature displayed and the actual temperature. It is usually expressed in terms of degrees, or percent of input span.

Set Point Assembly Accuracy

Set point assembly accuracy refers to the amount of error that could exist between the indicated setting and the set point signal sent to the controller. It is usually expressed in terms of degrees, or percent of set point span.

Indication Resolution

Indication resolution is the minimum interval between two marks on the temperature scale. **Set point resolution** is the minimum interval between two adjacent hash marks on the set point potentiometer scale. Indication resolution affects readability. Set point potentiometer scale resolution affects setability.

Repeatability

Repeatability is stated as the amount of agreement among several output measurements at all levels of input signal under identical operating conditions. It is usually expressed in terms of percent of input span. Repeatability is one of the determinants of accuracy. It does not include variables such as hysteresis. (Hysteresis is a change in the process variable required to re-energize the control or alarm output.)

Control Indicators

Temperature controllers display their operating status in two forms—analogue and digital. When referring to indicators, the terms analogue and digital **do not** refer to the controller's signal processing method—just the style of display.

Analog

Analog indication of process temperature can be achieved with a **direct reading meter**. A needle moving over a dial scale reads actual process temperature. The desired control point is set by adjusting a separate pointer over this same scale.

Another form of analogue readout is the **deviation indicator**. Process set point is established by adjusting a scale setpot. Display of actual process temperature is then detected on a separate deviation (null) meter that indicates temperature relative to the set point.

Digital

Digital indication of the process and set point temperatures is now predominant in the industrial world. Two types of digital displays are the light emitting diodes (LED) and the liquid crystal display (LCD). Each one has certain advantages that may make it more desirable than the other.

LEDs are the volume leader in industrial applications. They provide a bright display that is easily seen in poor or no light conditions. LEDs come in many sizes and colors. They are rugged and reliable.

LCDs have gained in prominence in recent years. They require very little power to function. Therefore, they are very desirable in portable equipment. The LCD does not emit light, but rather reflects existing light.

Application Guide

Temperature Controllers

Thermal Control Principles

Continued

Control Types, Open or Closed Loop

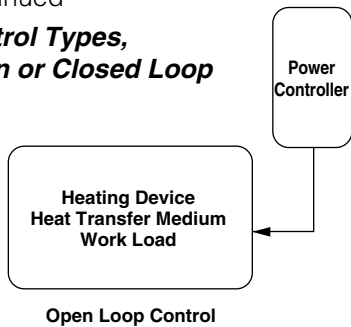

Ref. 56

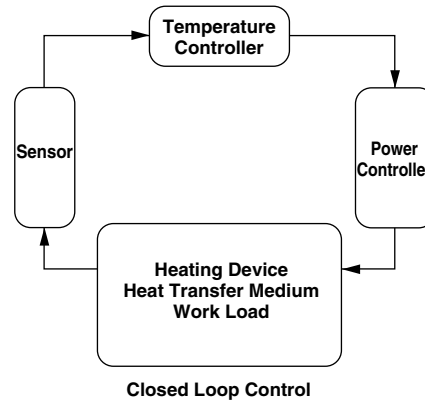

Temperature controllers are of two basic types—open loop and closed loop. An **open loop**, or manual, control device is one that has no self-correcting feedback information. The **closed loop**, or automatic, controller uses feedback information from the sensor to properly regulate the system. As process temperature changes, the feedback loop provides up-to-date status information that allows the controlling device to make self-correcting adjustments. The closed loop control device is a much more desirable approach to temperature control.

Control Modes

There are a variety of control modes that provide differing degrees of controllability. The most common modes are **on-off** and **PID** control. The PID control category includes devices of varying degrees of complexity that are capable of providing accurate, stable control under a variety of conditions.

On-off Ref. 57

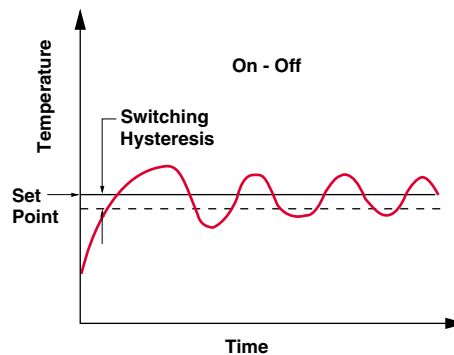

Time vs. Temperature Profile Developed by On-Off Control

The operation of the on-off control is just as the name implies; the output device turns full on or it turns full off when reaching set point. Temperature hysteresis (sensitivity) is designed into

the control action between the on and off switching points. This temperature hysteresis is established to prevent switching the output device on and off within a temperature span that is too narrow. Switching repeatedly within such a narrow span will create a condition known as output "chattering" (intermittent, rapid switching).

Temperature is always controlled "about set point." This is dictated by the switching hysteresis (also sensitivity or switching differential) of the on-off control. The control action further dictates that there will always be a certain amount of temperature overshoot and undershoot. The degree of overshoot and undershoot will be dependent on the characteristics of the entire thermal system.

Proportional

Proportional control is required for a more precise control of process temperature. A proportional control operates in the same way as an on-off control when a process temperature is far enough away from set point to be outside the proportional band. When process temperature approaches set point and enters the proportional band, the output effective power level is reduced.

Time proportioning is an output

method of controlling effective power. It delivers proportional control with a nonproportional output device (on-off), such as electromechanical relay, solenoid valve, MDR or zero-cross fired SSR. At the lower limit of the band, as the process temperature more closely approaches set point, the ratio of on to off time changes; the amount of on time decreases as the off time increases. This change in effective power delivered to the work load provides a throttling-back effect

which results in less process temperature overshoot. At that time, the system will be stabilized such that process temperature is controlled at a point below set point.

The process temperature stabilizes with a resultant droop. This condition will remain providing there are no work load changes in the system.



Refer to page 90 How the Process Output Works."

Application Guide

Temperature Controllers

Thermal Control Principles Continued

Integral (Reset)— Compensating For Droop Ref. 58

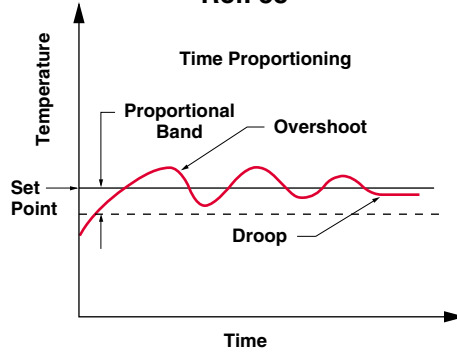

**Time vs. Temperature Profile
Developed by Proportional
Control in a Heat Application**

If the temperature droop cannot be tolerated, there are ways to compensate for it. They are manual reset and automatic reset (integral). Reset, or “integral,” compensates for droop.

Manual Reset

Ref. 59

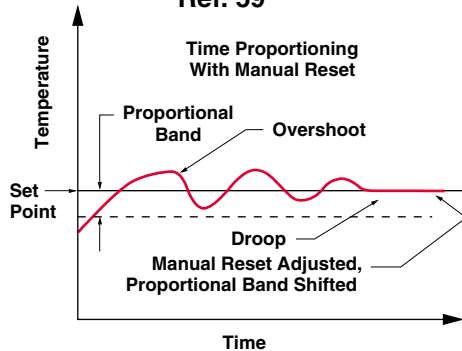

**Time vs. Temperature Profile
Developed by Proportional Control
With Manual Reset in a
Heat Application**

Manual reset is an adjustment that must be made by the operator which compensates for droop. This adjustment brings the process temperature into coincidence with the set point by shifting the proportional band. If the set point or thermal system is changed, coincidence between set point and process temperature will be lost; therefore, the manual reset adjustment will have to be made again.

Application Guide

Temperature Controllers

Thermal Control Principles

Continued

Automatic Reset

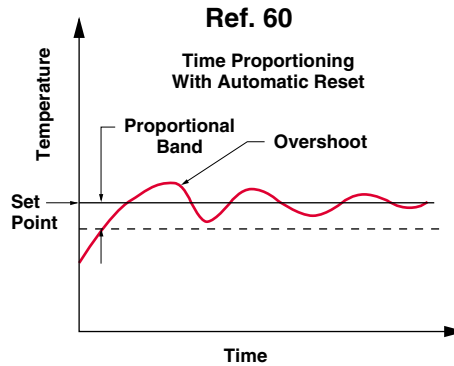

Time vs. Temperature Profile Developed by a Proportional Plus Integral Control in a Heat Application

Automatic reset (integral) is an automatic adjustment that is made by the control output power level to compensate for a droop condition when it exists. An integration function takes place that automatically compensates for the difference between set point and actual process temperature. This integration automatically adjusts output power to drive the process temperature toward set point.

Automatic reset action is prevented until the process temperature enters the proportional band. If it was allowed to take place at any point in the span of control, a condition of extreme temperature overshoot would occur. This function of eliminating the auto-reset is referred to as “anti-reset windup.”

Note that the condition of droop does not exist in this graph.

Derivative (Rate)—Compensating for Overshoot

As all of the process temperature graphs have illustrated, temperature overshoot occurs with any control mentioned thus far. This condition may be hazardous to certain processes and therefore cannot be tolerated. It is preventable with a control function known as “rate.”

Rate

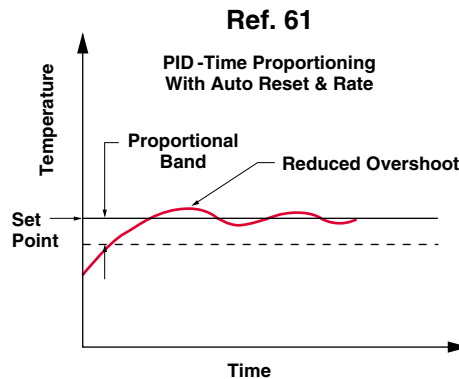

Time vs. Temperature Profile Developed by a Proportional Plus Integral Plus Derivative (PID) Control in a Heat Application

Derivative (rate) is an anticipatory function in a temperature control that measures the rate of change of process temperature and forces the controller to adjust output power on an accelerated basis to slow that change. This action prevents a large degree of overshoot or undershoot on start-up and also functions to prevent overshoot or undershoot when system disturbances would tend to drive the process temperature up or down.

A proportioning control with the automatic reset and rate (PID control) provides the type of control required for difficult processes which result in frequent system disturbance, or applications which need precision temperature control.

Note the effect of automatic reset by the lack of droop and the effect of rate by the reduced amount of process temperature overshoot on start-up.

Application Guide

Temperature Controllers

Thermal Control Principles

Continued

Control Configuration

Inputs (measured variables) and output control action signals can be combined in a controller package to make a controlling device meet nearly any system demand. The four most common configurations are the **single loop**, **single loop with dual outputs**, **dual loop** and **dual loop with quad outputs**. Reference 66 represents **multi-loop control with eight loops** and **16 outputs**.

Single Loop Controller

Ref. 62

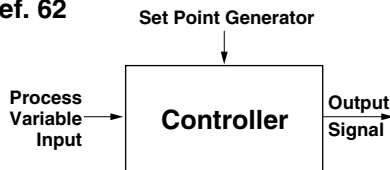

Think of it in terms of a closed loop (automatic) thermal system. The single loop is comprised of a heat source, controller, sensor and a final power switching device. One input and one output signal control the heat source relative to the set point.

Single Loop Controller Dual Outputs

Ref. 63

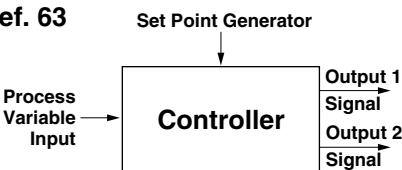

The controller now has two output signals that can be used for heat/cool output signals, heat/heat output signals, heat/high alarm output signals and many other combinations.

Dual Loops

Ref. 64

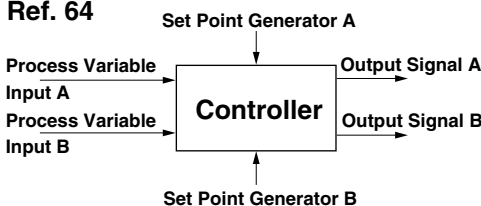

This controller can handle two independent process control loops having two separate inputs (measured variables) and output action signals.

Dual Loop Quad Outputs

Ref. 65

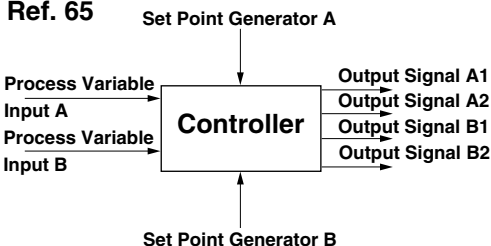

The controller now has two output signals for each independent loop. A common example of this configuration is one loop of temperature control with heat/cool output signals and a separate loop of humidity control with humidify/dehumidify output signals.

8-Loop Controller/Multi-Loop Controller

Ref. 66

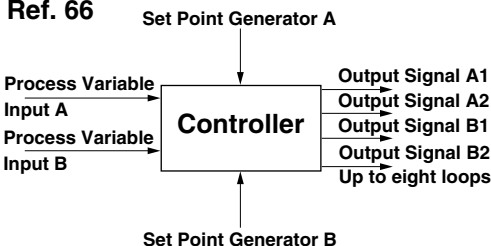

For a multi-loop controller with more than eight loops, repeat this configuration for the number of loops in the packaged system.

Control Input Signal Basics

Input signals can be generated by temperature **sensors** and other measurable process variables such as pressure, humidity and location. However, temperature sensing is the most common with signals created

through two basic methods—a change in small voltages, or a change in resistance. There are four basic types of temperature **sensors** and their selection depends on economy, the type of work being measured, its temperature range, the desired response time and operating

environment. Sensors generating a small voltage input signal are generally **thermocouples** and **infrared**. Sensors generating a change in resistance are **RTDs** and **thermistors**. See the “Temperature Sensors” section of this Application Guide for specific information, [page 33](#).

Application Guide

Temperature Controllers

Thermal Control Principles

Continued

Control Output Signal Basics

Cool Mode Example:

- Temperature controller on-off
- Cool mode (direct acting) relay type switching device

Heat Mode Example:

- Temperature controller on-off
- Heat system
- Relay switching device

High Alarm Example:

- Alarm output on-off
- Heat or cool system
- Relay switching device

Output Signal Terminology

We have already looked at the part of a controller which decides if the actual process variable is above or below the desired set point. We've also examined the varying percentage of the available output signal. This signal provides deliberate guidance

for the final switching device. The output signal, in turn, achieves the desired value for the process variable or an alarm-related action. Common types of output or signals are the **direct acting output** and the **reverse acting output**.

Direct Acting Output (Cool Mode) Ref. 67

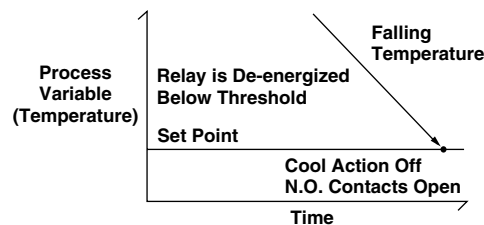

This is the controller action in which the value of the output signal increases as the value of the input (measured variable) increases.

This function is termed direct because the relay is de-energized or the contacts drop out (output decreases) as the temperature decreases. Think of this in terms of refrigeration. The refrigerator compressor is on, removing heat energy. When the freezer temperature is below set point, the output action decreases.

Reverse Acting Output (Heat Mode) Ref. 68

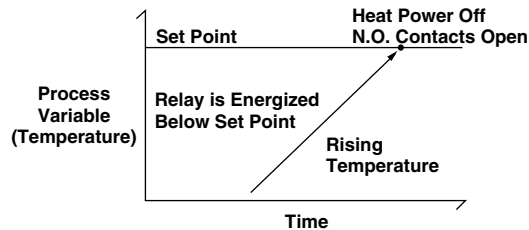

This is the controller action in which the value of the output signal decreases as the value of the input (measured variable) increases.

This function is termed reverse because the relay is de-energized or the contacts drop out (output decreases) as the temperature increases. Think of it in terms of cooking in an oven. As the temperature rises, the heat source is turned off at a predetermined set point.

High Alarm Output (Heat or Cool System) Ref. 69

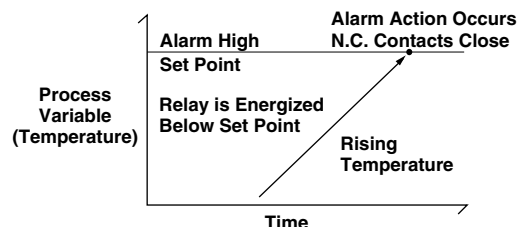

This controller action warns of danger in the system when the value of the input (measured variable) increases, passing through a predetermined

alarm (set point). The output signal may use a "latching" output feature that requires operator action to stop the alarm signal, thereby removing the "latch."

The high alarm function will warn an operator if a heat mode system is too hot and will cause damage to the process (heat fails to turn off). It also could warn an operator if a cooling mode system has failed to remove the heat from the system (cooling fails to turn on), resulting in damaged product.

Application Guide

Temperature Controllers

Thermal Control Principles

Continued

Low Alarm Example:

- Alarm output on-off
- Heat or cool system
- Relay switching device

Low Alarm Output (Heat or Cool System)

Ref. 70

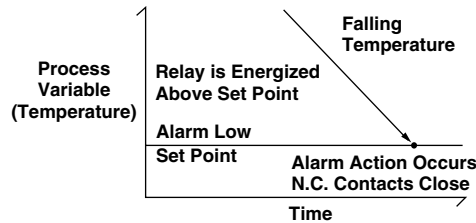

This controller action warns of danger in the system when the value of the input (measured variable) decreases, passing through a predetermined

alarm (set point). The output signal may use a “latching” output feature that requires operator action to stop the alarm signal, or remove the “latch.”

The low alarm function will warn an operator before the process temperature drops low enough to cause damage to the process (heat fails to turn on). It also will warn an operator if the cooling system removes too much heat from the system (cooling fails to turn off) resulting in a temperature so cold it causes damage to the process.

High Limit Example:

- Limit on-off
- Latching output
- Relay switching device

High Limit (Heat System)

Ref. 71

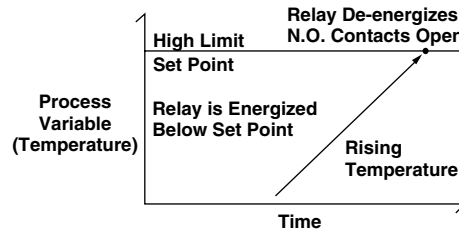

This controller action prevents the process from exceeding a predetermined high value by shutting down

the process as the value of the input (measured variable) increases, passing through a predetermined set point.

Note the major difference when comparing the high limit and high alarm function. The limit output is always a latching output and uses the normally open relay contacts in a de-energized state above the set point. That way, if the limit itself fails or has no power, the system will shut down in a safe condition.

Low Limit Example:

- Limit on-off
- Latching output
- Relay switching device

Low Limit (Cooling System)

Ref. 72

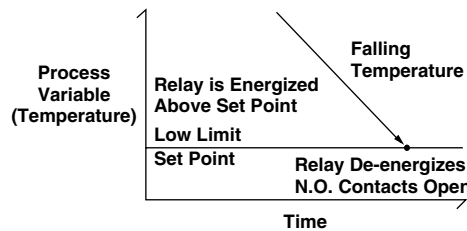

This controller action prevents the process from exceeding a predetermined low value by shutting down the process as the value of the input (measured variable) decreases,

passing through a predetermined set point.

A limit controller must have a separate power supply, sensor and a latching output feature requiring operator action to restart the process.

Note the major difference when comparing the low limit and low alarm function. The limit output is always a latching output and uses the normally open relay contacts in a de-energized state below the set point. That way, if the limit itself fails or has no power, the system will shut down in a safe condition.

Application Guide

Temperature Controllers

Control Output Types

The Mechanical, or Electromechanical Relay Control Output

The Watlow temperature controller's mechanical relay output is an electro-mechanical device. When power is applied to the relay coil, contact closure is created through movement of the "common" (COM) contact of the relay.

Because this relay has moving parts, it is susceptible to vibrations and eventual mechanical failure. The repeated closure of the contacts finally results in contact failure through burning and pitting. General guidelines to project the life of Watlow mechanical relay outputs are:

- 100,000 cycles at full rated load
- 500,000 cycles at $\frac{2}{3}$ rated load
- 1,000,000 cycles at $\frac{1}{3}$ rated load

Electromechanical relays provide a positive circuit break (with the exception of small current leakage through noise suppression components, RC suppression). This is important in many circuits. This contrasts with solid state devices which almost always have a minute amount of current leakage. Mechanical relays usually cost less initially, but must be replaced more often. Solid state devices can potentially last indefinitely, if not misapplied, so the eventual cost of the mechanical relay can surpass that of the solid state device.

Mechanical relays can be mounted in almost any position and are much easier to install and service than many solid state switches. They are offered with normally open (N.O.) and normally closed (N.C.) contacts. Many Watlow controllers with mechanical relay outputs have RC suppression to prevent electrical noise. Watlow recommends using a Quencharc® across the terminals of an output switching device if the controller has no internal RC suppression.

Advantages:

- Low initial cost
- Positive circuit break (with the exception of minimum leakage with noise suppression devices)
- May be mounted in any position
- Available with normally open and/or normally closed contacts
- Electrical isolation between coil circuit and load circuit
- Switches ac or dc

Disadvantages:

- Higher cost over time
- Relatively short life, depending on percent of rated load
- Contact arcing is a source of electromagnetic interference (EMI)
- May be sensitive to environmental conditions, such as dust and vibrations
- Derating with ambient temperatures above stated specification
- Can fail in either a closed or open state
- Warranted for 100,000 cycles only at rated current

The Solid State Relay Control Output

Watlow's solid state relay outputs change state at zero volts, which is burst firing. They are also optically isolated, which means the output circuitry is energized by infrared light striking a photo sensitive device. This results in the virtual absence of electrically generated noise, plus output-to-input electrical isolation.

Because solid state devices can operate much faster than electromechanical relays, they are employed where extremely tight process control is required. However, with the solid state devices connected to a second

switching device, the speed limitation of that device must be accounted for. In addition, the second device must tolerate the low current leakage of the solid state control output.

Like any other control output, the solid state output must have redundant limit control or other protection because it may fail in the closed state. Solid state devices are subject to damage from shorts in the load or load circuitry, as well as from transients and overheating.

Advantages:

- Electrically noise-free burst firing
- Faster cycle times
- Optically isolated from the control circuitry

- Used for tighter process control
- No arcing; clean switching

Disadvantages:

- Initial cost
- No positive circuit break; output current leakage
- Cannot be used with low power factor inductive loads
- Tend to fail in the "closed" position
- Cannot switch dc
- Requires minimum load current to operate

Quencharc® is a registered trademark of ITW Pakton.

Application Guide

Temperature Controllers

Control Output Types

Continued

The Switched DC Control Output

Since **solid state switches** have no moving parts, they have no mechanical failures. These solid state switches are more resistant to shock and vibration than mechanical relays. The absence of moving parts provides silent operation.

Watlow's switched dc output provides a small dc signal to trigger an external power switching device such as a

solid state relay. The input specifications of the power switching device must match those listed for the solid state switch output. The solid state switch is an open collector, switched dc signal that provides a minimum turn on voltage of $3V_{DC}$ into a minimum 500Ω load; maximum on voltage not greater than $32V_{DC}$ into an infinite load. The switched dc output is in most cases a **non-isolated output**. The device this output drives must provide isolation to prevent interaction with other power, input or output circuits. Watlow's dc input solid state power controllers provide this isolation.

Advantages:

- No moving parts, no mechanical failure
- Resistant to shock and vibration
- Can withstand a direct short circuit with no damage

Disadvantages:

- Non-isolated alone in most cases; requires additional isolated contactor, opto-isolator or switch wired to it
- Must match the specifications for the internal and external switching devices

The Process Control Output

The process output on Watlow controllers is wired through a device requiring a 4-20mA/0-20mA input with an input impedance of $600-800\Omega$ maximum; or a 0-10V_{DC}, 1-5V_{DC} or 0-5V_{DC} input with an input impedance of 1-5K Ω minimum. This may be a valve positioner, variable

power device such as a silicon controlled rectifier (SCR) or equipment requiring a current or voltage input. Specific versions of the Watlow QPAC, VPAC, POWER SERIES and DIN-A-MITE® will interface directly with the process output from the Watlow temperature controller.

The control provides the electrical

signal (4-20mA or 0-5V_{DC}) to drive the final load device. No external low volt source is required. The process output in most cases is a non-isolated output. The device this output drives must provide isolation to prevent interaction with other power, input or output circuits.

Choosing the Right Solid State Relay Control Output for Your Application

The key to selecting the correct Watlow controllers solid state relay output is knowing the application. What downstream device will you switch with the controller's solid state relay output?

If you are switching a solenoid, a mercury displacement relay (MDR), or a mechanical relay or contactor, you need Watlow's 0.5A solid state relay (SSR) with RC (Quencharc® brand) suppression for noise immunity. This integral RC network dampens any noise generated by the downstream output device.

On the other hand, if you are switching an ac input solid state relay (SSR), an ac input SCR (Watlow DIN-A-MITE, QPAC), or other high impedance loads (typically 5K Ω , like a piezoelectric buzzer, or neon lamp), you need Watlow's 0.5A solid state relay (SSR) without contact suppression. **The absence of the Quencharc® RC network eliminates output leakage across the contacts,** and thus the possibility of false firing.

Another way to phrase the question is: Do you need RC suppression with your solid state relay control output, or will your output device tolerate output leakage? Solenoids, MDR, and mechanical relays or contactors tend

to generate noise spikes that require RC suppression. AC input solid state relays (SSRs), ac input SCRs, and other high impedance loads are subject to output leakage and false firing—choose solid state relay without RC suppression.

If you need more information, including how to remove or add noise suppression to or from a solid state relay control output, call you Watlow sales agent, authorized distributor, or a Watlow application engineer.

Application Guide

Temperature Controllers

Control Output Types

Continued

How the Process Output Works

When the control calls for an increase in the actual process value (heat, flow or pressure, etc.), and when the actual value is outside the controller's proportional band, the process output turns full on. With a 0-5V_{DC} process output, full on measures five volts; with 4-20mA, full on measures 20mA.

In a reverse acting, or heat mode, as the actual process value moves

toward set point and enters the proportional band, the output signal decreases proportionately. Ideally, the system will proceed to set point without overshoot. As the system stabilizes at set point, the process output signal becomes constant at a value between 0-5V_{DC} or 4-20mA. System thermal characteristics and control PID settings combine to determine the final, stable value of the process output signal.

The control output power level is represented by a linear process signal:
 0% power = 4mA or 0V_{DC}
 100% power = 20mA or 5V_{DC}
 50% power = 12mA or 2.5V_{DC}

Advantages:

- No moving parts
- Silent operation
- Resistant to interference; low noise susceptibility; low impedance, current loop

Disadvantages:

- Non-isolated in most cases requires isolated contactor or power device connected external to control
- Maximum load impedance 600-800Ω for current output
- Minimum load impedance 1-5kΩ for voltage output

Control Output Comparison—Ref. 73

| I want to switch... I want to control... | Controller Output | Output Life |
|--|---|-------------|
| <ul style="list-style-type: none"> • Solenoid coil/valve • Mercury displacement relay (MDR) • Electromechanical relay • General purpose contactor | Solid state relay with RC suppression | |
| <ul style="list-style-type: none"> • AC input solid state relay (SSR) • AC input solid state contactor • High impedance load, typ. ≥ 5kΩ • Piezoelectric buzzer • Indicator lamps | Solid state relay without contact suppression | |
| <ul style="list-style-type: none"> • Various devices in on-off mode with RC suppression | Electromechanical relay | |
| <ul style="list-style-type: none"> • Various devices in on-off mode (high impedance or inductive devices with coils suppressed) • Indicator lamps • Small heaters • AC input solid state contactor | Electromechanical relay without contact suppression | |
| <ul style="list-style-type: none"> • A safety limit circuit with contactor, electromechanical relay or mercury displacement relay (MDR) | Electromechanical relay with RC suppression | |
| <ul style="list-style-type: none"> • Various devices in on-off mode • Solenoid coil/valve • Mercury displacement relay (MDR) • Electromechanical relay • General purpose contactor • Pilot duty relays | Electromechanical relay with RC suppression | |

Application Guide



Temperature Controllers

Control Output Types

Continued

Ref. 73 continued

| I want to switch... I want to control... | Controller Output | Output Life |
|--|--|-------------|
| <ul style="list-style-type: none"> • Various devices in on-off mode (high impedance or inductive devices with coils suppressed) • Indicator lamps • Small heaters • AC input solid state contactor | Electromechanical relay without contact suppression | |
| <ul style="list-style-type: none"> • DC input solid state relay (SSR) • PLC-dc input • Low voltage panel lamp | Switched dc, isolated | |
| <ul style="list-style-type: none"> • DC input solid state relay (SSR) • PLC-dc input • Low voltage panel lamp | Switched dc, non-isolated | |
| <ul style="list-style-type: none"> • DC input solid state relay (SSR) • PLC-dc input • Low voltage panel lamp | Open collector, isolated | |
| <ul style="list-style-type: none"> • 100mA minimum load • Electric resistance heaters | Triac | |
| <ul style="list-style-type: none"> • Phase angle or burst fire SCR • 0-20mA=(dc)^① valve positioner • Cascade control • Other instruments | Process 0-20mA=(dc), non-isolated | |
| <ul style="list-style-type: none"> • Phase angle or burst fire SCR • 4-20mA=(dc) valve positioner • Cascade control, • Other instruments | Process 4-20mA=(dc), non-isolated | |
| <ul style="list-style-type: none"> • Multiple SCRs, phase angle or burst fire • 0-5V=(dc), 1-5V=(dc) or • 0-10V=(dc) valve positioner • Cascade control • Other instruments | Process 0-5V=(dc), 1-5V=(dc), 0-10V=(dc), 0-20mA=(dc), 4-20mA=(dc), isolated | |
| <ul style="list-style-type: none"> • Multiple SCRs, phase angle or burst fire • 0-10V=(dc) valve positioner • Cascade control • Other instruments | Process 0-10V=(dc), non-isolated | |
| <ul style="list-style-type: none"> • Sensor transmitters • Ancillary devices | Power supply, 5, 12 or 20V=(dc) @ 30mA | N/A |

-  **Best Life**
-  **Better Life**
-  **Good Life**

^① Watlow power controller process inputs calibrated for 4-20mA unless otherwise specified with order.





Application Guide

Temperature Controllers

Control Output Types

Continued

Control Output Comparison—Ref. 73 continued Retransmit/Alarms

| I want to switch... I want to control... | Controller Output | Output Life |
|--|---|--|
| <ul style="list-style-type: none"> • 1 or 2 devices, impedance dependent • Chart recorder • Master-remote (slave) system • Data logging device | 0-20mA=(dc), 4-20mA=(dc), non-isolated |  |
| <ul style="list-style-type: none"> • 1 or 2 devices, impedance dependent • Chart recorder • Master-remote (slave) system • Data logging device | 4-20mA=(dc), non-isolated |  |
| <ul style="list-style-type: none"> • Multiple devices, impedance dependent • Chart recorder • Master-remote (slave) system • Data logging device | 0-5V=(dc), non-isolated |  |
| <ul style="list-style-type: none"> • Multiple devices, impedance dependent • Chart recorder • Master-remote (slave) system • Data logging device | 0-5V=(dc), 1-5V=(dc), 1-10V=(dc), Isolated |  |
| <ul style="list-style-type: none"> • Various devices in on-off mode | Electromechanical relay, Form A or B, with RC suppression |  |

 **Best Life**

 **Better Life**

 **Good Life**

Application Guide

Temperature Controllers

Limit Control Protection for Temperature Process

Good engineering can minimize system failures. “Safety first” is a good rule to follow. To that end, here are some suggestions for protecting against over- and undertemperature conditions.

Introduction to Limit Control Protection

What follows will define limit control and provide recommendations on limit control protection in a temperature

Disclaimer of Warranty

This is a general overview and statement of the safety-related need for and methods of applying “limit control protection for temperature processes.” Because of the diversity of conditions and hazards under which controller products may be applied and because of the differences in components and methods of their installation, **no representation or warranty of any kind,**

express or implied, is hereby made, that the limit control protection discussed and presented herein will be effective in any particular application or set of circumstances, or that additional or different precautions will not be reasonably necessary for a particular application.

We will be pleased to consult with you regarding a specific application upon request.

Keys to Safe Limit Control Protection

Limit control protection is a system safeguard often required for agency approval, government regulation or for insurance protection. In other systems where potential faults also exist, limit control protection makes good sense, like wearing a life jacket or a hard hat. It's easier in the long run to have a limit control in place rather than to recover from the consequences of a serious system fault. In addition, the value of the process equipment, the value of the product in the equip-

control loop where a potential fault condition could result in damage to equipment, property and personnel. All devices have a finite life. Consequently, system faults can be caused

by a defective or worn sensor, power controller, heater or temperature controller. Limit controllers can take a process to safe, default conditions if equipment failure occurs.

ment and time lost in an accident are usually well worth the extra level of protection limit controllers provide.

Limit control protection has two keys:

- **Limit control reliability-** use a quality, agency-approved limit controller where one is required.
- **Redundant control-** using separate power supply, power lines and sensor, the limit controller can take the process to a safe, default condition when an over- or undertemperature fault occurs.

Warning

Limit Controller Application—Install high or low temperature limit control protection in systems where an overtemperature or undertemperature fault condition could present a fire hazard or other hazard. Failure to install temperature limit control protection where a potential hazard exists could result in damage to equipment and property, and injury to personnel.

Watlow Limit Control Products

Watlow offers three limit controllers suitable for use in environments where hazards exist, the SERIES 94 and

SERIES 97. Certain models of these are either UL® 873-recognized as temperature regulating controllers or FM-approved as temperature limit

switches, or both. Consult the wiring examples contained in the “Wiring Practices” section, [page 115](#), of this Application Guide.

Application Guide

Temperature Controllers

Agency Recognition for Controllers

In certain applications, the circumstances require the control circuit electronics and associated system hardware to be tested by an independent laboratory to meet specific construction and operation requirements with respect to hazards affecting life and property. There are several independent test laboratories in the U.S. and many throughout the world. The following are the common standards to which most of our products are designed and built:

- UL® 50: Type 4X Enclosure (NEMA 4X)

- UL® 873: Temperature Indicating and Regulating Equipment
- UL® 197: Commercial Cooking Appliances
- UL® 508: Industrial Control Equipment
- UL® 3101: Laboratory Equipment
- UL® 3121: Process Control Equipment
- UL® 991: Tests for Safety-Related Controls Employing Solid State Devices
- CSA Std C22.2 No. 24-93: Temperature Indicating and Regulating Equipment; C22.2 No. 109-M1981 Commercial Cooking Appliances; C22.2 No. 14-M1973 and C22.2 No. 14-M1987 Industrial Control Equipment

- CE: 89/336/EEC Electromagnetic Compatibility Directive and 73/23/EEC Low Voltage Directive
-  UL®: UL® Tested to Applicable CSA C22.2 Standard
- NRTL* approved to ANSI Z 21.23-1993: Gas Appliance Thermostats
- FM: Class 3545 Approved Temperature Limiting Switch

Watlow furnishes many stock products that have recognition for various agency file numbers.

Please check the product catalog listing or, for special assistance regarding your unique requirements, consult your local Watlow sales office.

*Nationally Recognized Testing Laboratory

Control System Tuning

In this phase of making the system work, we will focus on the process controller as the primary component of a closed loop system that must be adjusted for optimum performance. These adjustments provide a means to compensate for system problems. For instance, when the sensor cannot be placed in the most desirable location because of physical limitations, a PID controller can compensate for the sensor's resulting thermal lag problem.

Tuning Methods

Tuning temperature controllers is accomplished either manually or automatically. Manual tuning is just that—manually setting each of the controller's operating parameters. Automatic tuning, or auto-tuning, is

possible through the use of digital, microprocessor-based, electronic circuitry. With auto-tuning, the controller has a "program" inside its memory that will calculate the correct setting for each of the controller parameters.

Auto-Tuning

For Watlow controllers, the auto-tuning automatically sets the PID parameters to fit the characteristics of your particular thermal system.

Once the auto-tune sequence has begun, the heat proportional band is set to 0 and the controller goes into an on-off mode of control typically at 90 percent of the established set point. The display set point will remain unchanged.

Once the controller learns the thermal system response, it returns to a standard PID control using PID values automatically set as a result of auto-tuning. Output 2 cool PID values are also set on certain Watlow products, such as the SERIES 93, 96, 935, 988, and F4 family. Consult your Watlow

representative. Any change to set point, while in auto-tune, reinitiates the auto-tune process.

Some Watlow temperature controllers, featuring auto-tune, will not auto-tune while in remote set point. Transferring from local to remote set points takes the controller out of auto-tune. Generally, to complete auto-tuning, the process must cross the 90 percent set point four times within approximately 80 minutes after auto-tune has started.

The following graph visually represents the auto-tune process. Note that tuning is effected at 90 percent of temperature set point. Once auto-tuning is completed, the controller then brings the process to temperature.

Application Guide

Temperature Controllers

Control System Tuning

Continued

Ref. 74

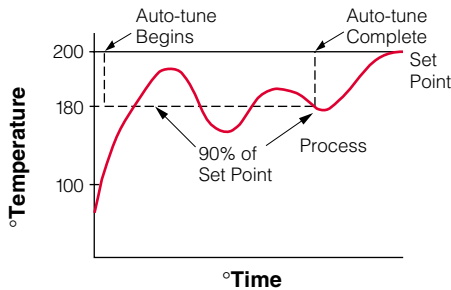

When auto-tuning is complete, the displays will return to their previous state. At this point, the controller will note the appropriate PID tuning parameters and save them in its non-volatile memory.

To abort auto-tuning, please refer to the controller's user manual, or cycle the power off and on.

For auto-tuning procedures specific to a particular temperature controller, always refer to that controller's user manual for details.

Auto-tune for Multi-loop Controllers (Watlow Anafaze)

Multi-loop controllers have an auto-tune feature that is designed to tune loops from a cold-start (or a stable state well below set point). A

controller will not tune a loop that is already at set point. When auto-tune is started, the controller sets the heat control output to MANUAL and holds the output at 100 percent (or at the output limit if a continuous output limit has been selected). The response of the process variable (PV) as it rises is analyzed to calculate the PID constants. When this process is complete, the controller puts the loop into AUTO with the new constants.

To avoid excessive overshoot, the controller will abort the auto-tune function if the PV goes above 75 percent of setpoint. It will also abort if it fails to calculate PID constants within a 10 minute time period (due to a related failure). If aborted, the loop will return to its previous control state.

Manual Tuning

The following steps for manual tuning are general and applicable to most manually set temperature controllers. Each is taken in sequence. However, when manually tuning **any** controller, always refer to and follow the recommended steps in that controller's User Manual. Many of these steps are accomplished "transparently"

with auto-tune temperature controllers. These manual steps are generally what's taking place in an auto-tuning controller.

Please take note of a few precautions:

- Take your time in tuning the control system. It will work a long time without further attention if done right.
- Do not change more than one control adjustment at a time, allowing the system to settle down and reach a state of equilibrium before making another change.
- Remember that the time you spend tuning the electronic controller system is relative to the precision of control you need.

Manual On-Off Tuning Factors

On-off Control Hysteresis Diagram

Ref. 75

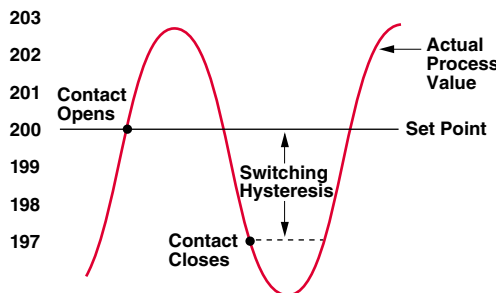

An **on-off** controller has a switching hysteresis that is used to define switching thresholds where the unit will change its output status.

Decreasing switching hysteresis will cause the output to change status more frequently (faster cycling) and reduce the excursions above and below set point. Increasing the hysteresis will produce the opposite results (slower cycling).

Application Guide

Temperature Controllers

Control System Tuning

Continued

Manual PID Tuning Factors

Conventional control parameter adjustments (PID), listed in the sequence in which they should be adjusted, are as follows:

Proportional Band

The **proportional band** adjustment is the means of selecting the response speed (gain) or sensitivity of a proportioned controller to achieve stability in the system. The proportional band, measured in degrees, units, or percent of span, must be wider than the natural oscillations of the system and yet not wide enough to dampen the system response. A side note: if the controller has a "time proportional" output, the cycle time should be set as short as possible while tuning, and then reset longer to reduce wear on the system, but not so long as to degrade system response.

The time proportioning output must be set to switch faster than the natural oscillation of the system, sometimes called, "system cycle time." One system variable that can limit the cycling speed of the control output is the switching device. A mechanical relay is hundreds of times slower than a solid state device. The shorter the

controller cycle time, the better the system response, but it must be balanced against the maximum switching life of the controller's output.

The tuning procedure is very simple if a recorder is available to monitor the actual process variable. If a recorder is not available, observe the process response and record readings over a defined time period.

Set the proportional band to 25° and allow the system time to stabilize. If there are oscillations, double the proportional band. If no oscillations are present and the system is stable, cut the proportional band in half. Allow time for the system to stabilize. Continue to double or halve the proportional band until the system again becomes unstable. Adjust the proportion band in the opposite direction in small increments. Allow time between adjustment for the system to stabilize. Continue until the process is stable $\pm 1^\circ$ and power is stable ± 5 percent.

Integral (Reset)

The **reset** adjustment, manual or automatic, is tuned at this point to correct for the droop that is caused by the proportional output.

- Controllers with **manual reset** should have this parameter adjustment set initially at the "mid-range" setting. The operator will make small increment adjustments in the proper direction (increase or decrease) to bring about coincidence between the actual process temperature and the desired set point.

Please make small changes in the reset adjustment and allow the system to return to a state of equilibrium before making additional changes. This may take several system cycle times. Also, manual reset will have to be changed if the set point or other thermal characteristics are changed substantially.

- **Automatic reset** would seem to imply that it would not require adjustment. While it does automatically make correction for offset errors, it has to be tuned to each unique system. Each system has its own characteristic response time (sys-

tem cycle time). Thus, the auto reset time constant (repeats per minute) must be tuned to match the overall system response time.

Begin by setting automatic reset to 0.50 repeats per minute. Then allow the system time to stabilize. If there are oscillations, cut the reset value in half. If no oscillations are present and the system is stable, double the reset value.

Application Guide

Temperature Controllers

Control System Tuning

Continued

Derivative (Rate)

Rate is the last control parameter adjustment to be made. Rate's function is to reduce or eliminate overshoot or undershoot (excursions above or below set point). It has a time base (measured in minutes) which must be tuned to work with the overall system response time (system cycle time). The initial setting for rate should be at 0.5 minutes after each adjustment

increase the set point moderately. Observe the approach of the actual process temperature to set point. If it overshoots, continue to increase the rate integer in small increments. If the system oscillates, cut the rate value in half. If it overshoots and stabilizes, double the rate value. Then increase the set point temperature moderately until optimum approach to set point is achieved.

Recommended Tuning Reference

There are many reference books on the art of tuning electronic controllers to the systems they control. If you are not an instrument technician qualified to tune thermal systems, we suggest that you obtain and become familiar with the following reference before attempting to tune your system.

"Controller Tuning and Control Loop Performance" "PID Without the Math"

by David W. St. Clair
Available from:
Straight-Line Control Co., Inc.
3 Bridle Brook Lane
Newark, DE 19711-2003

Typical Thermal Control System Chart Recordings

This section contains typical chart recorded temperature responses of a temperature controller output plotted by a chart recorder. A 20 watt silicone rubber heater on a small aluminum load block with a Type J thermocouple input provides the heat source, load and feedback system. We connected the chart drive sensor input in parallel with the controller's sensor so that the recorder would read the same system response.

Ref. 76

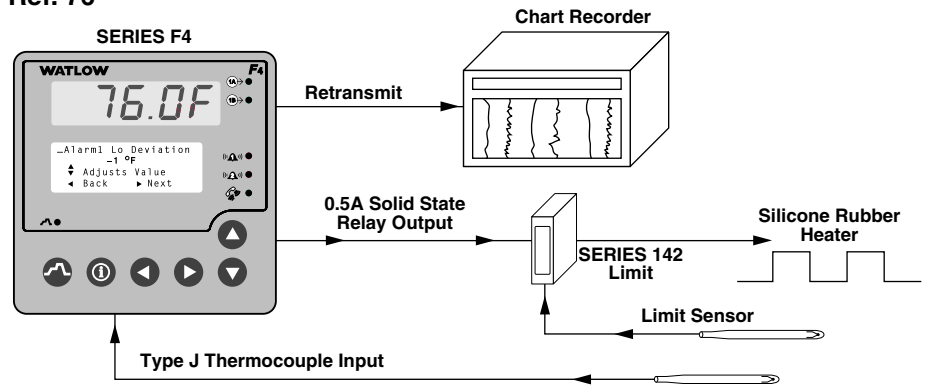

Typical Temperature Controller With SERIES F4 Driving a Chart Recorder

Sample chart recordings on the following page will assist you in:

1. Understanding the application and tuning of Watlow controllers.
2. Demonstrating the usefulness of chart recorders in tuning thermal systems.
3. Providing a means of observing several tuning settings quickly.
4. Demonstrating how a change in one PID parameter can affect system stability and response.

These charts represent one type of system response. Nonetheless, they provide a representative look at a real thermal system.

The charts go from on-off control, through proportional control with no reset or rate, to proportional control with reset and no rate. Phenomena exhibited on the charts are:

- Oscillations of an on-off control, and response to a set point change

- Oscillations reduced by adding a proportional band
- Proportional control with a set point change
- Droop correction with reset
- Set point change in a control with proportional and reset action
- More rapid and less stable response to set point change, caused by increased reset action

Application Guide

Temperature Controllers

Typical Thermal Control System Chart Recordings

Continued

Ref. 77

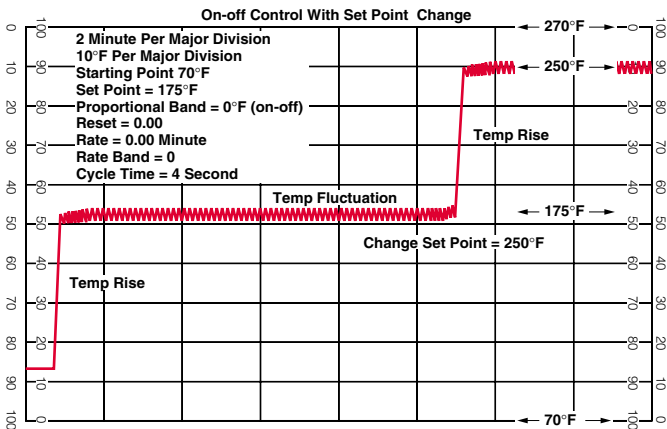

Ref. 78

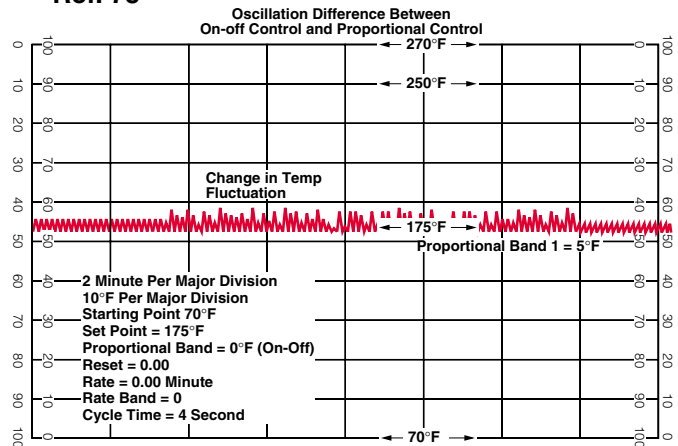

Ref. 79

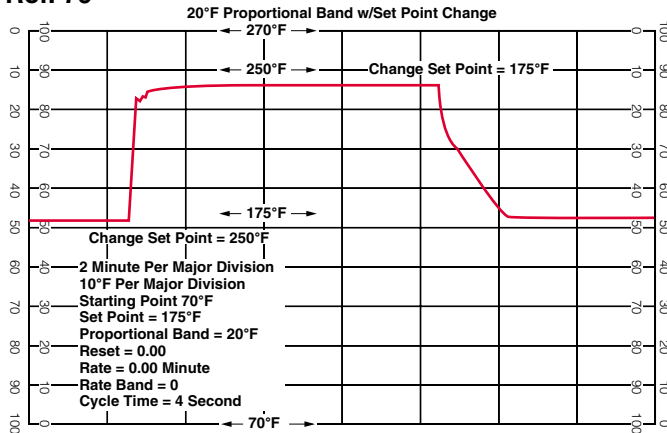

Ref. 80

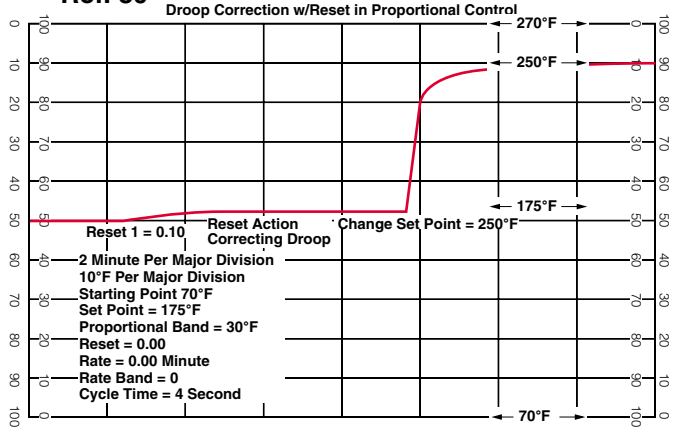

Ref. 81

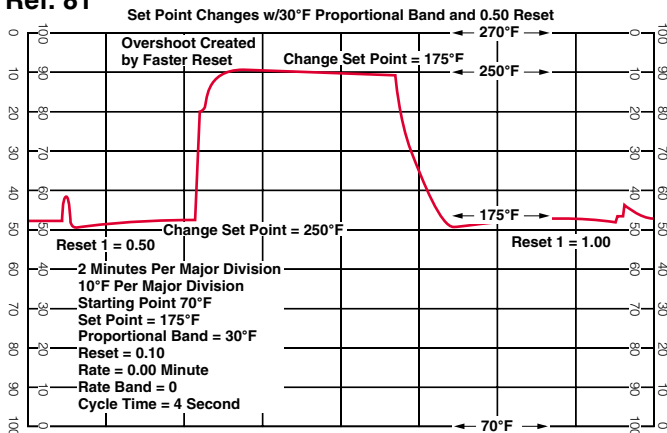

Ref. 82

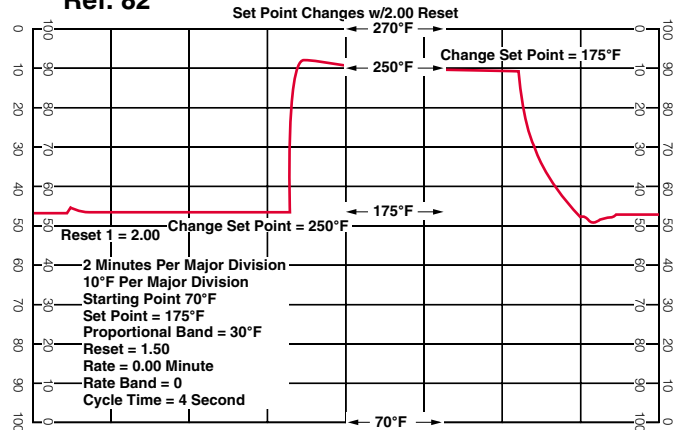

Application Guide

Temperature Controllers

Controller Overview

Watlow offers controllers of two different types, temperature controllers and power controllers. Control panels are pre-assembled temperature and power controller packages mounted in a suitable electrical enclosure.

A temperature controller produces an output action based on the input signal received from a sensor. Controllers used in cooling applications are called direct acting. Controllers used in heating applications are called reverse acting. Depending on the controller, output actions can control a heating or cooling device, or some other aspect of a process (ratio mixing, conveyor speed, etc.).

Temperature controllers are either single-loop or multi-loop. Single-loop temperature controllers are good for basic temperature control. Various levels of sophistication can reduce temperature under-and over-shoot, produce alarm actions and perform data logging functions as well as serial communications.

Multi-loop temperature controllers (also called process controllers) are good for applications where temperature and other process variables need to be controlled in a coordinated fashion.

Temperature controllers are either single-loop or multi-loop. Single-loop controllers have one input, and one or more outputs to control a thermal system. Multi-loop controllers have multiple inputs and outputs, and are capable of controlling several aspects of a process. More control loops permit controlling and coordinating more process system functions.

Single-Loop Auto-Tuning

Used to automatically set PID parameters for optimum thermal system performance. Capable of accepting a variety of sensor inputs, including thermocouple, RTD and process. The controller senses the rate of temperature increase (reverse acting) or decrease (direct acting) and adjusts the output action to minimize set point over- and under-shoot. PID output action requires a solid state power controller to withstand rapid switching cycles. Auto-tuning controllers can have more than one output channel for alarms, retransmit and serial communications. Selected controllers are available in CE compliant versions.

Some controllers feature a percent power default operation or will de-energize the system upon sensor break. Controllers with NEMA 4X front panels are well suited for wet or corrosive environments.

Applications include batch processing ovens and furnaces, environmental chambers and analytical equipment.

Basic

Used for non-critical or unsophisticated thermal systems to provide on-off temperature control for direct or reverse acting applications. The basic controller accepts thermocouple or RTD inputs and offers an optional percent power control mode for systems without temperature sensors. This category also includes cartridge thermostats. These units operate on their sheath's thermal expansion and are available in reverse and directing acting modes. They can be wired interconnected or for pilot duty with a relay. The cartridge thermostat can also serve as a non-latching limit controller. Applications include foodservice and general process control.

Time/Temperature Profiling (Ramping)

Programmable auto-tuning controllers (see auto-tuning above) are able to execute ramp and soak profiles such as temperature changes over time, along with hold, or soak/cycle duration. Selected controllers are available in CE compliant versions. Applications include heat treating, complex process furnaces and environmental chambers.

Limits/Alarms

These controllers are specifically designed to provide safety limit control over process temperature. They are capable of accepting thermocouple, RTD or process inputs with limits set for the high or low temperature. Limit control is latching and part of a redundant control circuit to positively shut a thermal system down in case of an over-limit condition.

Multi-Loop

Two-Loop

These units can receive two inputs and produce two or more outputs for direct and reverse acting control. They accept thermocouple, RTD, process and event inputs. Auto-tuning (see auto-tuning above) automatically sets PID parameters for optimum performance. Outputs include alarms, events, process, serial communications and data logging. Selected controllers are available in CE compliant versions. Applications include foodservice equipment, complex process furnaces and environmental chambers.

Four to 32-Loop

Available in versions that supply four, eight, 16 and 32 control loops, the controllers can accept thermocouple, RTD, process, linear and pulse inputs. A selected eight loop version also accepts carbon potential. Auto-tuning automatically sets PID parameters for

Application Guide

Temperature Controllers

Four to 32-Loop con't

optimum performance. Job recipe storage permits preprogramming to speed batch setup. Outputs include digital, alarms, events, process, serial communications and data logging. Optional PC communications permits remote operation and monitoring.

Custom Controls

Watlow Custom Controls Group provides design, engineering, testing/debugging and production. But more than that, Watlow provides you with a cooperative partnership based on service, ongoing product support and electronic controllers solutions. We have the experience, stability and total thermal system expertise to produce the controller that's right for your application.

Watlow offers the most modern engineering, testing and production

facilities; our focus on electronics means we put significant investment in state-of-the-art technology. Our engineers participate in a continuing education and training program that keeps our team on the cutting edge of innovation. We work with your team to give your company that competitive edge.

Custom Controllers Capabilities

Hardware Design

- Microprocessor, analog and discreet digital
- Surface mount technology
- Through-hole technology
- Qualification lab
 - Electromagnetic compatibility
 - Environmental testing
 - Shock and vibration
- Agency approvals

PC Board Design

- Multi-layer
- Double-sided

Software Design

- High level language for flexibility and fast development
- Software demo design
- Communications
- Application overview screens
- Custom menus and functions
- Custom logic functions
- Custom communication protocols

Resources

- Hardware engineers
- Software engineers
- Technicians
- PC designers
- Mechanical designers
- Account managers
- Customer service agents

Additional Custom Capabilities

- Customization of standard single and multi-loop controllers
- Custom electronic contract assembly and system integration
- Custom control panels with or without turnkey heating systems

Data Communications

In addition to data logging, many digital, microprocessor-based temperature controllers offer serial (data) communications. This feature allows a central computer to monitor and control one or several temperature controllers.

The uses of serial communications are many and varied, depending on your application requirements. Space doesn't permit a detailed explanation of this temperature controller feature.

However, the main benefit of connecting temperature controllers to a central computer is the ability to more fully automate a process.

Depending on the central computer's programming, it can be set to operate in different capacities. The most common is to have the computer act as a single "control panel" for multiple temperature controllers. This relieves production personnel of monitoring

and manually operating many physically isolated controls. Other uses include monitoring and controlling processes for SPC (statistical process control), or gather data to prepare certificates of compliance. This eliminates the task of manual data collection and processing.

Serial communication is the exchange of data in a one-bit-at-a-time, sequential manner on a single data line or channel. It relies on the controller's and computer's ability to use a common protocol to govern their interaction, or communication. Because they are less prone to both operator and noise induced error, protocol-driven communications are more accurate than other forms of computer communications.

Protocols

Watlow uses three protocols, two of which are the simple XON/XOFF Protocol (flow control), and Full

Protocol, based on ANSI X3.28- 1976, Subcategories 2.2 and A3. For more information on Data Communications you can download a copy of the "Data Communications Reference: Electronic Users Manual" for the Watlow web site. Both of these are based on the ASCII character code. ASCII (American Standard Code for Information Interchange) is almost universally used to represent each letter, punctuation mark and number we use.

A third protocol is referred to as Modbus™ RTU. This expands the communications ability of the controller by enabling a computer to read and write directly to register containing the controller's parameters.

For specifics on how serial communications can meet your process temperature control and monitoring needs, please contact your Watlow sales engineer, or the factory.

Modbus™ is a trademark of Schneider Automation Incorporated.

Application Guide

Power Controllers

The discrete output device that acts in response to a deliberate guidance from the temperature controller is the power controller.

There are four common power controllers: electromechanical relays, mercury displacement relays, solid state relays and silicon controlled rectifiers (SCRs). The first two use magnetic devices to actuate power switching. The latter two use solid state electronics to effect the switching function. The selection of a specific power controller type depends on the method of control being used, system power demands, degree of temperature control (accuracy to set point), the heater type and heater life requirements.

Watlow manufactures a wide range of mercury displacement relays, solid state relays and SCR power controllers in ratings to meet almost all power



switching needs. Each is manufactured to the highest standards of reliability and performance. For more information specific to power

controller types, models and ratings, see the "Power Controllers" product section of Watlow's Temperature and Power Controller's catalog, page 121.

Product Overview

Power Controllers

Watlow solid state power controllers complement the rapid switching required by PID temperature controllers and help deliver optimum system performance and service life. Available in 1-phase and 3-phase/2-leg and 3-leg configurations, Watlow power controllers meet most industrial heating applications. Random, zero cross or phase angle fire options match the power controller to the application requirement. DIN-A-MITE SCR power controllers provide a convenient DIN rail mount package in current ratings from 18 to 100 amperes – a good replacement for equal mercury displacement relays. Qpac SCR power controllers rated up to 1,000 amperes for those large process heating applications. POWER SERIES microprocessor based SCR power controllers with ratings from 65 to 250 amperes. The POWER SERIES offers extensive system and heater diagnostics features and agency approvals. SERIES CZR is a CSA, VDE and UL® recognized contactor with ratings from 18 to 50 amperes single phase. Single solid state relays from 10 to 75 amperes. E-SAFE® relay is a 3-pole hybrid solid state/mechanical relay with current ratings of 20 and 40 amperes and is UL®-508 listed and C-UL®. E-SAFE is a good mercury displacement relay replacement in the amperages it serves.

Application Guide

Power Controllers

Product Overview

Continued

Applications

- Semiconductor processing
- Plastics processing
- Heat treating
- Drying ovens
- Foodservice equipment
- Petroleum / chemical
- Lighting equipment
- Glass processing
- Furnace / oven

DIN-A-MITE A

- Ratings to 25 amps
- Single-phase configuration
- Contactor or burst fire firing options

DIN-A-MITE B

- Ratings to 40 amps
- Single- and three-phase configuration
- Contactor or burst fire firing options

DIN-A-MITE C

- Ratings to 80 amps
- Single- and three-phase configurations
- Contactor, burst fire and phase angle firing options

DIN-A-MITE D

- Ratings to 100 amps
- Single-phase configuration
- Contactor or burst fire firing options

SSR

- Ratings from 10 to 75 amps
- Single-phase configuration
- V~(ac) or V=(dc) contactor firing options

QPAC

- Ratings from 30 to 1,000 amps
- Single- and three-phase configurations
- Contactor, burst fire and phase angle firing options

POWER SERIES

- Ratings from 65 to 250 amps
- Single- and three-phase configurations
- Contactor, burst fire and phase angle firing options

SERIES CZR

- Ratings from 18 to 50 amps
- Single-phase configuration
- V~(ac) or V=(dc) contactor firing options

E-SAFE

- Ratings from 20 to 40 amps
- Three-phase configuration
- 24, 120 and 220 input, V~(ac) Contactor

Five Basic Types:

The **electromechanical contactor, or relay** is an electrical and mechanical device with moving parts. When power is applied to the relay solenoid, contact closure is created through movement of the relay's "common" contact.

1. Electromechanical Relay

Because this contactor has moving parts, it is susceptible to vibration or mechanical failure. The closure of the contacts when powered results in contact failure through burning and pitting, which, in fact, is the primary

Ref. 83

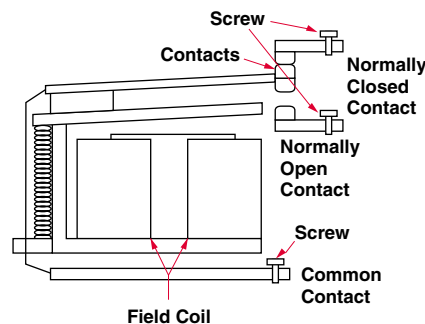

reason for failure of an electromechanical relay. A general guideline for projecting the life of higher quality mechanical relays is as follows:

1. 100,000 cycles at full rated load
2. 500,000 cycles at $\frac{2}{3}$ rated load
3. 1,000,000 cycles at $\frac{1}{3}$ rated load

Electromechanical contactors provide a positive circuit break. This is important in many circuits. This contrasts with solid state devices which almost always have a small amount of leakage current flow.

Electromechanical contactors can be mounted in almost any position and are much easier to install and service than many solid state switches. They are offered with normally open and normally closed contacts, with a very slight cost differential for both contacts.

Application Guide

Power Controllers

Five Basic Types

Continued

2. Mercury Displacement Relay (MDR)

Ref. 84

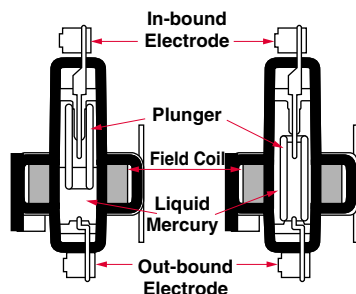

Mercury displacement relays have completely encapsulated contacts that rely on mechanical movement to function. However, the relays are designed so that the moving parts are restricted to a confined area and any contact as a result of this movement is between Teflon® and metal. The contacts do not wear due to the mercury within the capsule. Mercury does not pit and burn like metal. The mercury contacted is actually ever-changing.

Mercury displacement relays provide a positive circuit break, are small in size, are low in cost and provide a barely audible noise when switching.

The mercury displacement relay combines the best features of the electromechanical relay and the solid state switch. The primary advantage of the electromechanical relay is its ability to switch considerable amounts of power at a low cost. One of the primary advantages of the solid state device is long life. The MDR combines these features. While the electromechanical relay costs less (by $\frac{1}{3}$ to $\frac{1}{2}$), the MDR will provide the long life desired. The MDR can typically outlast the electromechanical relay by a factor of 100 to one or more. The MDR is rated to operate at full load for up to 15 million cycles, which provides extended life as with solid state relays.

3. Solid State Relays

Ref. 85

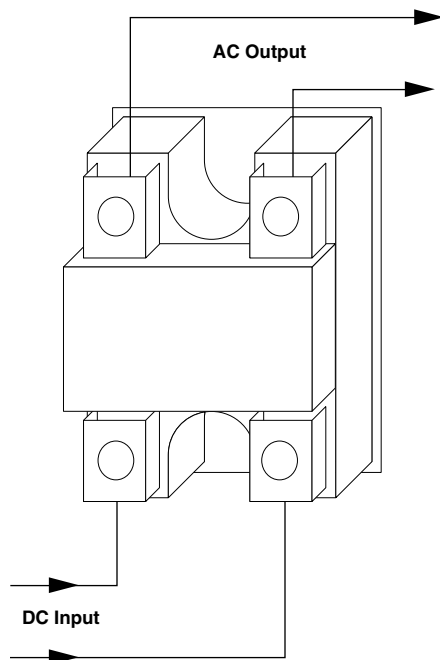

Solid state switching devices have no moving parts and consequently, no mechanical failures. Solid state switches are resistant to shock and vibration. The absence of moving parts also makes them noise-free (they produce no audible sound). The most important factor affecting service life is its ambient operating temperature. Solid state devices are very durable, **if they are operated within tolerable ambient temperatures**. Failure to dissipate the heat generated by any solid state component will quickly destroy it. Location and heatsinking must be adequate.

Watlow solid state relays accept a time proportioned or on-off signal from a controller.

Watlow's solid state relays change state near zero volts, which is burst firing. They are also optically isolated, which means the output circuitry is energized by infrared light striking a photosensitive device. This minimizes electrically generated noise, plus output to input electrical isolation.

Because solid state relays can operate at much faster cycle times than electromechanical relays, they should be employed where extremely tight process control is required.

Disadvantages of solid state relays include the inability to provide a positive circuit break, the initial cost, and their failure mode when misapplied or subjected to overrated conditions. The failure modes include burnout of the switch if the system heater shorts out; reduction in switching capabilities as the ambient temperatures rise; and susceptibility to failure caused by line transients and inductive loads.

These failure modes can be eliminated to a great degree by proper fusing of switches for overload conditions, increasing the heat sinking (the overall size) for high ambients, and filtering for the transients and inductive loads. Each of these will increase the cost of the solid state relay.

Application Guide

Power Controllers

Five Basic Types

Continued

4. E-SAFE Relay®

The **E-SAFE® relay** is a long life hybrid relay that uses a mechanical relay with a triac in parallel with the contacts to turn on and off the load at the zero cross point in the sine wave. Once the triac has turned on the load for one cycle, the mechanical relay is energized to pass the current until the

turn off sequence when the triac again turns on for one cycle and then turns off at zero cross. This eliminates the contacts from arcing and greatly increases the life of the mechanical relay.

Ref. 86

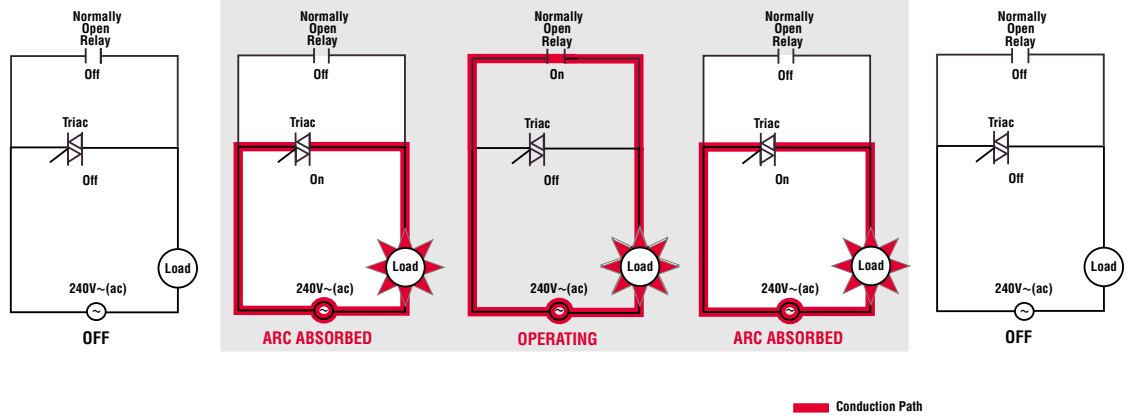

Application Guide

Power Controllers

Five Basic Types

Continued

5. SCR (Silicon Controlled Rectifier)

The Watlow SCR (silicon controlled rectifier) is a solid state switching device that can switch up to a 1200 amp load. A correctly chosen SCR can reduce system cost by improving heater life and process controllability.

SCR Power Control

Ref. 87

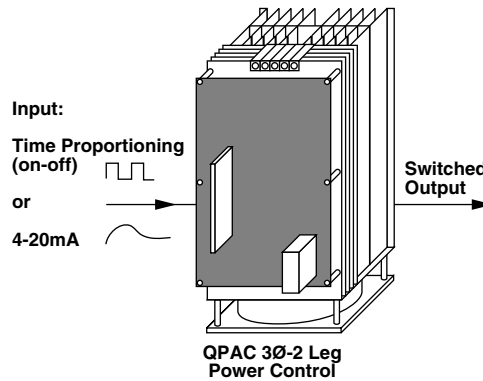

Watlow SCR power controllers can accept two types of input signals; time proportioned (or on-off) and process signals (either 4-20mA or 1-5V_{DC}) from any temperature control. SCRs accepting time proportioned (or on-off) signals are generally called "power contactors." SCRs accepting process signals (4-20mA or 1-5V_{DC}) are generally called "power controllers." They control the power by two methods of firing, phase angle and variable time base burst firing.

The primary advantages of SCR power controllers are their flexible input options, lack of moving parts, long life, improved controllability and tremendous current handling capability.

A Watlow SCR can improve system performance with increased heater life through the rapid switching an SCR provides.

All SCRs, including Watlow's, require a proper heat sink. Heat is the inevitable by-product of solid state power switching.

The Power Switching Device Comparison Chart on [page 114](#), details differences among the controllers listed above. The criteria for judging these devices, as well as some basics for understanding SCRs, will follow in this section.

Reduced Temperature Excursions

Ref. 88

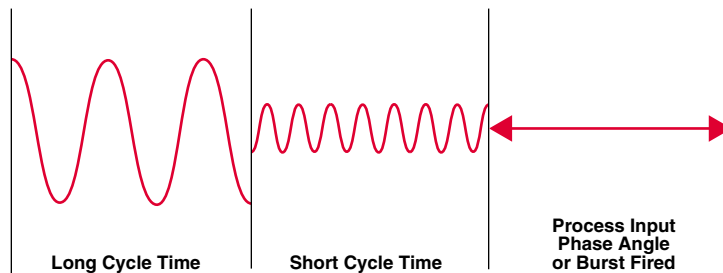

Temperature Controllers

Proper Heat Sinking

Ref. 89

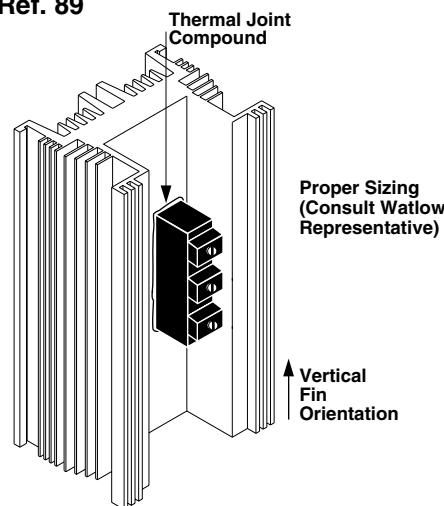

- Vertical fin orientation
- Proper size
- Thermal compound between heat sink and solid state device

Application Guide

Power Controllers

Five Basic Types

Continued

5a. DIN-A-MITE® SCR Power Controller

The DIN-A-MITE® power controller combines SCR control, heat sink, wiring and a touch safe exterior in one complete package. The DIN-A-MITE controller configured with variable time base switches as fast as three ac wave cycles (less than 0.1 seconds). Set point deviation is virtually eliminated, providing the finest control, lowest power consumption and longest heater element life.

Ref. 90

Power Output Types:

| | |
|-------------------|---|
| One pole | Single-phase loads |
| Two pole | Three-phase ungrounded loads only Two pole multizone for two independent single-phase loads |
| Three pole | Three phase grounded Y loads, inside delta Three pole multizone for three independent single-phase loads |

Type of Control:

- Contactor (C input) is on-off; on when the command signal is present, off when the command signal is absent. The temperature controller does the proportioning. It is available with ac or dc command signal.
- Variable time base (V input) is loop powered and requires an analog input (4 to 20 mA only) to set the power. The DIN-A-MITE controller does the proportioning. At 50 percent power the load is on for three cycles and off for three cycles. At 25 percent power it is on three cycles and off nine. Cannot use voltage or pot input.
- Phase angle (P input) control is infinitely variable from full off to full on. It varies the turn-on time inside the sine wave. This provides a

variable voltage and current control. This option includes soft start, line voltage compensation and will work with a mA signal, a linear voltage signal or a pot input. It will also control the primary of a step down transformer. (This is single phase only.)

- The shorted SCR alarm option uses a current transformer to sense load current and a comparator to look at load current and command signal. If there is command signal and load current, everything is OK. If there is load current but no command signal, the alarm will activate. The alarm output is a 0.25 amp triac that can be used to turn on a relay. The alarm will not work on the phase angle option and also will not work on a three pole DIN-A-MITE with an ungrounded load.

Ref. 91

Inside Delta Connection Three-Phase-Three Leg DIN-A-MITE

Notes

1. SCR current is same as one heater.
2. Circuit breaker and CR1 are line current.

Advantage

1. A smaller DIN-A-MITE can be used.

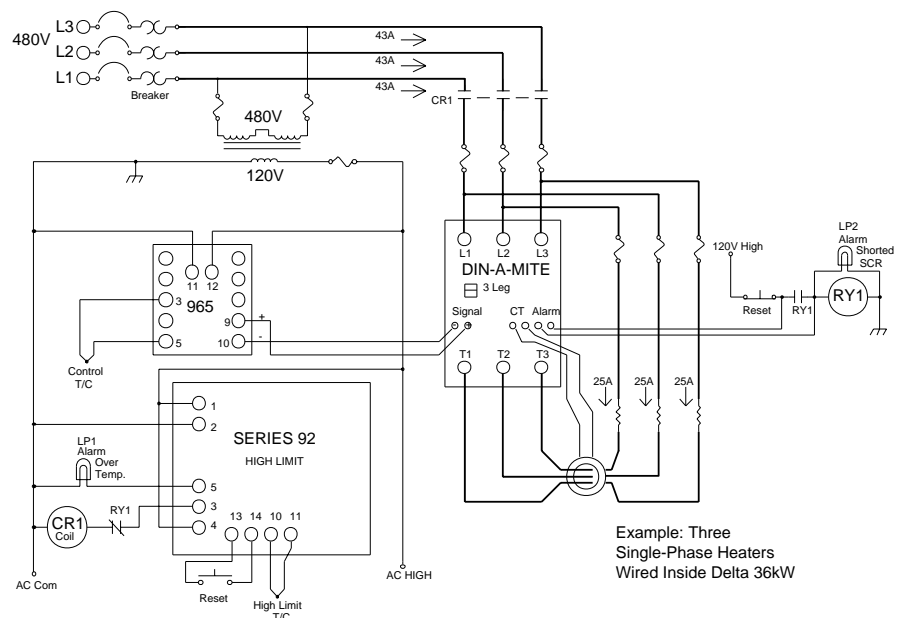

Application Guide

Power Controllers

5b. POWER SERIES

Ref. 92

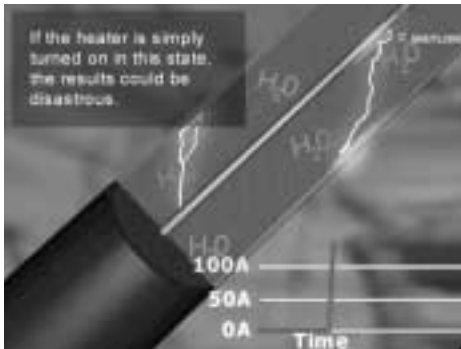

The POWER SERIES is a state-of-the-art microprocessor based silicon controlled rectifier (SCR) power controller intended for controlling industrial heaters. This product is based on one package with several configurations that include single-phase, three-phase and single-phase-multizone capabilities. Each package configuration has a specific current rating depending on the number of phases switched. The switching capabilities include 65 to 250A rms at 50°C from 24 to 600V~(ac) depending on the configuration or model number selected.

It is available in the following configurations:

1. Single-phase for zero cross or phase control applications.
2. Three-phase, two-leg for zero cross applications.
3. Three-phase, three-leg for zero cross or phase control.
4. Single-phase, multi-zone for two or three single zones that can be either zero cross or phase control.

Options include heater diagnostics, heater bake out, communications and retransmit of current or KVA.

Heater Bakeout

If a system is shut down for long periods, some heaters can absorb moisture. With a standard power controller, turning the full power “on” when moisture is present, can cause the fuses or the heater to blow.

However, with the POWER SERIES you can now “bake out” the moisture in a wet heater before applying full power and destroying the heater. During heater “bake out” the POWER SERIES slowly increases voltage to the heater while monitoring the output current. If the heater achieves full output before the bakeout time expires, then the heater is dry and can be put into service. At all times, the output will not exceed the temperature controller set point.

If output current reaches a user-specified trip point during the bakeout (as it would if arcing occurred in the heater), then the POWER SERIES shuts off the output and activates an over-current trip error. The operator should then lengthen the bakeout time and restart or just restart, depending on how long the initial bakeout ran. To start heater bakeout you must cycle the controller power. After a successful heater bakeout, the POWER SERIES automatically switches to the operator pre-selected control mode (phase angle or zero cross).

Note: Heater bakeout is intended for magnesium oxide filled nichrome elements. A nichrome element heater can have a tolerance up to ±10 percent. This tolerance could add to the maximum heater current during normal operation. For example, a 50-amp heater could draw 55 amps and still be a good and dry heater.

Heater bakeout may be selected in single phase (phase to neutral) and three-phase, six SCR systems with any preselected control mode. You must always have the heater diagnostics option installed on your POWER SERIES.

Application Guide

Power Controllers

Theory of SCR Power Controllers

AC voltage changes polarity according to the frequency of the current. In North America this is usually 60 times a second. In Europe and many other parts of world, this is 50 times a second. Polarity changes at zero voltage potential. Circuits which detect this zero point are called "zero cross detectors."

Alternating Current

Ref. 93

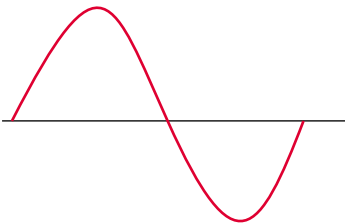

Diode

Ref. 94

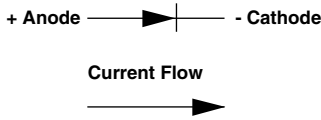

A diode allows current to flow in one direction. It's on or current is flowing, when the anode is positive with respect to the cathode.

SCR

Ref. 95

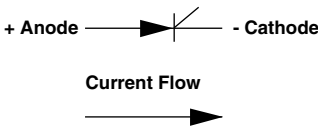

The SCR, like a diode, can only pass current in one direction. The voltage polarity (anode-to-cathode) must be positive when applying a signal to the gate. Once on, it latches and will only turn off when the cathode becomes more positive than the anode. This happens after passing through zero into the opposite polarity on the alternating current (ac) sine wave.

Back-to-Back SCRs

Ref. 96

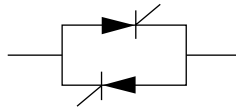

Energizing the gate will turn the SCR on for one half ac cycle. Going through zero will turn it off; correspondingly, the second SCR (facing the opposite direction) must be turned on.

Hybrid (SCR & Diode)

Ref. 97

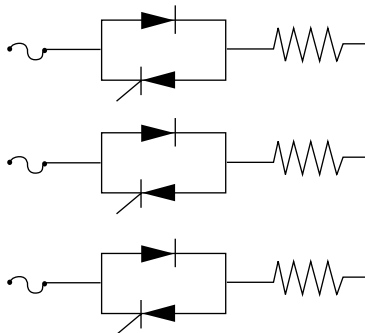

Three-phase applications require two or three pair of back-to-back SCRs, or may utilize SCRs and diodes. For some three-phase applications, there is an economy, as well as simplicity, in using three pair of hybrid thyristors. The diodes will conduct only if there is a return path. This return path exists when SCRs are gated on.

Forward Voltage Drop

Ref. 98

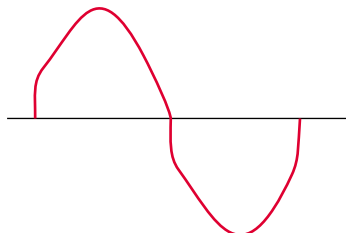

An SCR requires a small amount of voltage to turn on. Without a load connected, it will never turn on. Each time the SCR is turned fully on, there is a 1.2 volt forward drop on the ac voltage sine wave. This generates heat and produces some electrical noise.

Application Guide

Power Controllers

Methods Of Firing SCRs

1. Zero Cross

Zero cross (also known as burst firing) provides even output power with the lowest levels of noise generation (RFI). Zero cross is the preferred method for controlling a resistive load.

The power controller determines when the ac sine wave crosses the 0-volts point, then switches the load, minimizing RFI.

A. Solid State Contactor

Temperature controllers with a “time proportioning” output proportion heat to the process with an on and off command signal to the power controller. Proportioning is accomplished by turning the heat off for a longer time period as the actual temperature approaches set point. This is not to be confused with an on-off temperature control, where there is no proportioning.

SCR controllers designed to respond to this on or off signal are solid state contactors. They are capable of operating from a cycle time as short as one ac cycle. This rapid response to a fast proportioning signal produces excellent process control.

B. Burst Firing or Zero Cross

AC power alternates plus and minus 60 or 50 times per second (depending on power generation standards), thus 60/50 cycle. An SCR can accurately control each cycle. Burst firing provides a proportional output to the heater by turning on for a number of cycles and then remaining off for a number of cycles. The proportion on and off is according to the temperature controller’s command signal. A zero to 5V=(dc) signal with the output at two volts would have the SCR on 40 percent of the time. There are two types of burst-firing controllers:

- **Fixed Time Base**

Burst-firing (zero cross) controllers are available with either a one second or four second time base. In either case, the SCR is turned on for a time proportional to the command signal. In the example just mentioned (assuming 60 cycle ac current), the 40 percent would be 24 cycles on and 36 cycles off with a one second time base.

Fixed Time Base Ref. 99

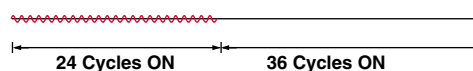

- **Variable Time Base**

Burst-firing (zero cross) controllers are also available with a variable time base. The on and off time is proportional to the command signal, but the time base changes according to the demand. At 50 percent it’s a two cycle time base, one cycle on and one cycle off. The example of 40 percent is two cycles on and three cycles off.

50 Percent Variable Time Base, 1 Cycle On, 1 Cycle Off Ref. 100

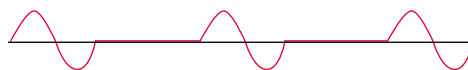

40 Percent Variable Time Base, 2 Cycles On, 3 Cycles Off Ref. 101



Burst firing is also called “zero cross firing” or “cycle proportioning.”

2. Phase Angle Firing

The SCR, once turned on, latches on and only turns off when the polarity changes. If the turn on point is not zero, but is delayed inside the sine wave, then the amount of power allowed to pass through the SCR can be controlled. This is called “phase angle firing.”

Phase Angle Firing Ref. 102

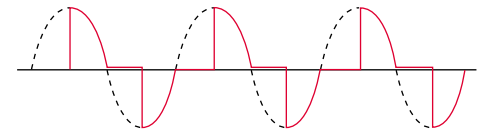

Soft Start is accomplished by delaying the turn on, and slowly increasing the on time in subsequent cycles with less delay. This allows heaters that change resistance with temperature to turn on slowly. This typically occurs over a 10 second period.

Soft Start Ref. 103

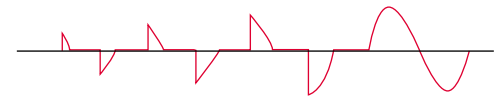

Current Limiting utilizes the same delay, and also has a transformer to sense current. A limit to the acceptable amount of current is established and the logic in the controller will not allow current above this predetermined value. However, if a short in the heater occurs during this on time, the resulting high current cannot be restricted from passing through the SCR. The only protection possible for the SCR is an I²t fuse that will blow within the ac cycle.

Current Limiting Ref. 104

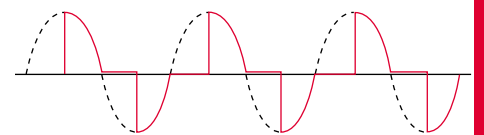

3. Combination

Utilizing the advantages of phase angle firing to turn heater loads on and switching to burst firing to maintain power appears to offer the best of both worlds. This has been tried where burst firing cannot be used at turn on. Unfortunately, the bursts of power have also been found to shorten the life of silicon carbide elements or transformers that the SCR is controlling.

Application Guide

Power Controllers

Methods Of Firing SCRs

Continued

SCR Firing Method Selection

Ref. 105

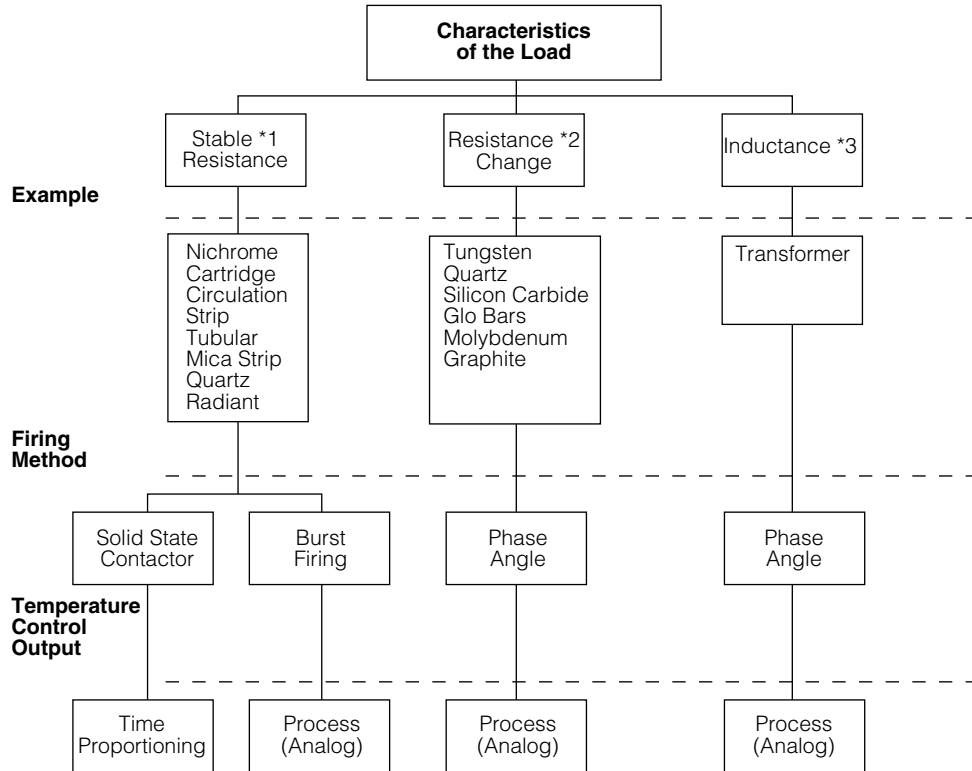

Notes:

*1. Nichrome heater elements change resistance less than two times in their operating temperature range.

*2. Heaters that change resistance include:

- Tungsten changes over 16 times from cold to hot
- Silicon carbide changes with temperature and age
- Molybdenum and graphite change resistance with the temperature and are often used on the secondary of a transformer

*3. Transformers can become dc saturated if two pulses of the same polarity are applied in sequence which can cause overheating and high currents that will damage the SCR. Burst firing should not be applied.

Application Guide

Power Controllers

Methods Of Firing SCRs

Continued

Single- and Three-Phase Controllers

1. Single-Phase Controllers Ref. 106

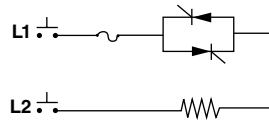

All single phase SCR controllers use one pair of “back-to-back” SCRs. This combination can be used for solid state contactors and burst firing or phase angle controllers.

2A. Three-Phase Controllers Six SCRs Ref. 107

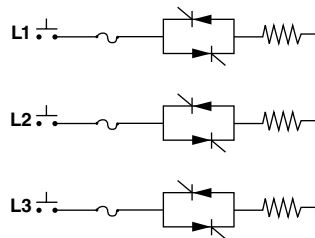

This is for use with phase angle controllers **only**. Because no two phases go through zero at the same time, it cannot be used with burst firing. There is no return path for the current at zero potential. With phase angle, this is the preferred control when the load is unbalanced, or for less common delta-to-delta transformers. Potential shock hazard (line to ground) is $\text{line} \div \sqrt{3}$.

2B. Three Pair SCR/Diodes Hybrid Ref. 108

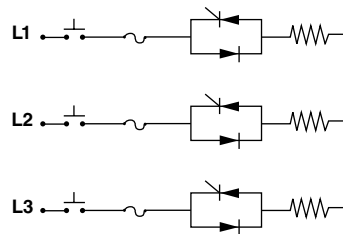

This is recommended for phase angle **only**. Because of the uncontrolled diode (dc), potential shock hazard is $\text{line} \times \sqrt{2}$. It can be used for burst firing but the two leg control is recommended. The advantage of a hybrid over a “back-to-back” is less cost and fewer components.

2C. Two-Leg Controller Two Pair SCRs Ref. 109

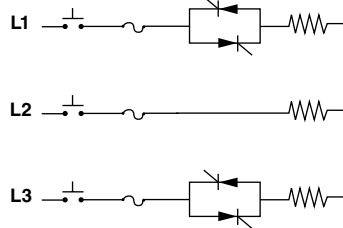

This is recommended for burst firing and cannot be used with phase angle. Potential shock hazard is $\text{line} \div \sqrt{3}$. It has $\frac{1}{3}$ fewer parts, which means it is less expensive, requires less maintenance, and generates less heat.

2D. Three-Leg, Four-Wire Controller Grounded Wye Only Ref. 110

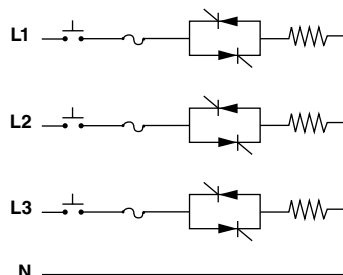

This is more common in comfort heating applications where it is desirable to have only one heater on each leg that is grounded and burst firing is desired. For use only with burst firing and grounded wye.

Temperature Controllers

Application Guide

Power Controllers Enclosure Guidelines



Power controllers must be mounted in a suitable electrical enclosure. It must have adequate wire bending space and cooling. The maximum ambient temperature in the enclosure must not exceed 50°C (122°F) for name plate rating.

To maintain the proper cooling, the enclosure must be large enough to dissipate the heat generated by the power controller, or there must be some form of active cooling.

1. Air circulation — fans bring air into the bottom of the enclosure and louver plates to allow the air to exit the top of the enclosure. Filters are not recommended as they can become plugged and block air flow. To maintain 80 percent of the CFM of a fan, the outlet must be four times the area of the fan inlet. Ensure that each power controller is within an unobstructed airstream.
2. Vortex coolers operate on compressed air and provide good cooling on a sealed enclosure, but are noisy and consume a lot of air.
3. Cabinet air conditioners work well on sealed enclosures.
4. Heat pipe coolers work well on sealed enclosures, but do not provide as much cooling as vortex coolers or air conditioners.

To determine how much cooling is required:

1. Determine the amperage load on the power controller. Multiply the amperage by 1.2 and then by the number of phases controlled. This is the output power dissipated by the SCRs in watts. Add the watts dissipated by the controller's power supply (21W) and multiply the total power in watts by 3.41 to get BTUs per hour. Vortex coolers, heat pipe coolers, and air conditioner cooling are rated in BTUs removed.
2. Add up the watts generated by other electronics in the enclosure and multiply by 3.41 to get BTUs per hour.
3. Add up the total BTUs inside the enclosure and pick a cooling device that will remove that amount of BTUs.
4. For fan cooled enclosures, enclosure and fan manufacturers usually have free software programs and application notes to help size the fans for enclosures. If necessary, contact the Application Engineers at Watlow Winona for assistance.

Application Guide

Power Controllers Heater Life and Selection of Power Handling Device

Heater Construction

Nichrome wire of computer-calculated gauge, length and spacing is wound on a supporting core. The resistance is precisely centered in the unit-equidistant to the sheath of all points. If the heater temperature cycles

between two values in a means to maintain the process temperature, this repeated excursion causes expansion and contraction of the resistance wire. This stress on the element will reduce heater life. The higher the excursion, the shorter the life.

Effect of Time Base on Temperature Excursion

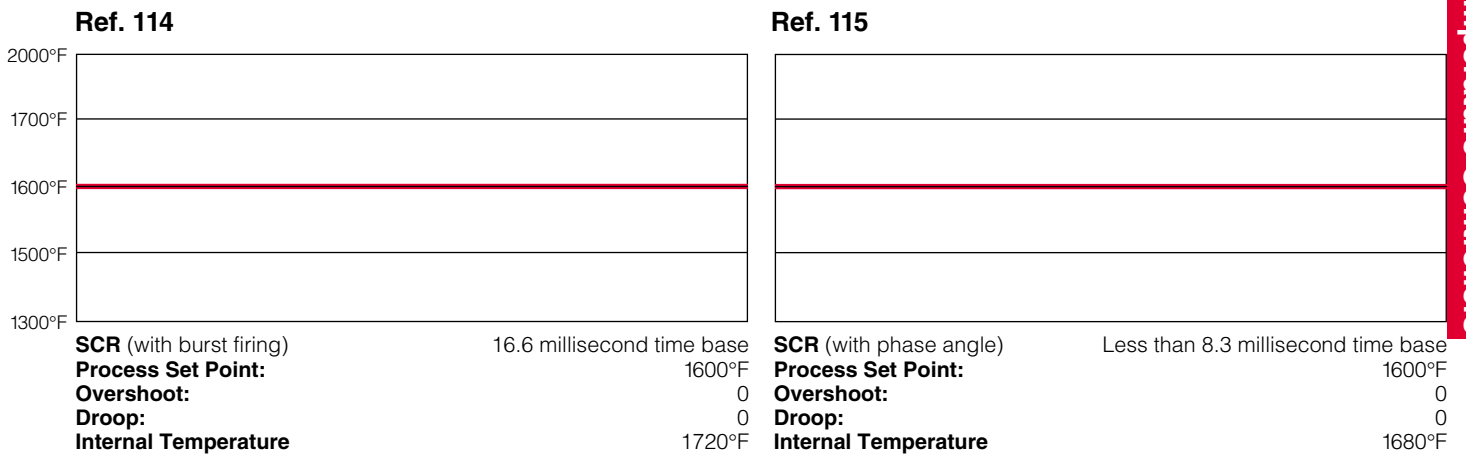
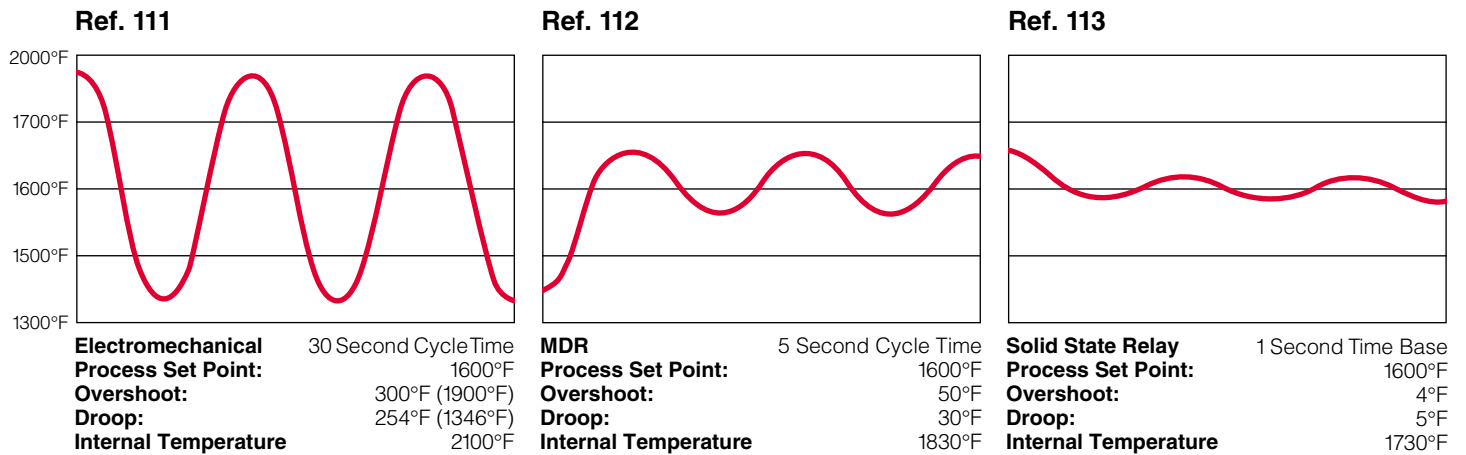

Temperature Controllers

Application Guide

Power Controllers SCR Protective Devices

1. Semiconductor Fuses

Semiconductor fuses are a specialty fuse that is intended for SCR protection only. They are very fast clearing and will open a short circuit in less than two milliseconds. The clearing time and clearing current are designated by I^2t . Current squared times time. This rating must be at or below the I^2t rating of the SCR to insure protection. Semiconductor

fuses need to be in all controlled legs. They are only intended to protect the SCR's and are not legal for cable or load (branch circuit) protection.

2. Current Limiting

A means of sensing current through a current transformer. Some heater elements change resistance during their operation, (i.e., silicon carbide). In order to control at a slow ramp, it is often advantageous to limit the current.

3. High Limit Control

The most common failure mode of an SCR is in the shorted state. If this

happens, the temperature controller can no longer control the SCR and a runaway condition exists. An independent high limit controller must be used that will sense unsafe temperature and disengage the power.

4. Heat Sink Thermostat

Removes signal from an SCR in case of fan failure, filter blockage, or excess heat in the enclosure. SCRs that incorporate a fan for forced cooling can reach unsafe temperatures if the fan fails. All Watlow SCRs with fan cooling incorporate a heat sink thermostat.

Power Controller Comparisons

The following chart is an abbreviated comparison of power controllers along with their suitability for use.

Power Switching Device Comparison Chart—Ref. 116

| Device | Initial Cost | 3 Year Cost* | Controller Life | Heater Life | EMI Generation | Control-ability | Response Rate | Options | Comments |
|--|---------------------|--------------|---------------------------|-------------|---------------------------|-----------------|----------------|---------------|--|
| Electro-mechanical Relay and Contactor | Low for low current | Highest | Limited (elec. and mech.) | Shortest | Yes, coil and contacts | Poor | Slowest | None | To extend contactor life the cycle time is normally extended to 30 seconds or more. This shortens heater life. |
| Mercury Displacement Relay | Low | Medium | High | Good | Yes, coil and contact | Medium to Good | Medium to Fast | None | Silent Operation. Mercury may not be desirable. Minimum cycle time is two seconds. Position sensitive. |
| Solid State Relay | Medium | Medium | Extended | Extended | Minimal with burst firing | Good | Fast | None | Excellent control with one second cycle time. Requires heat sink. May require snubber. |
| SCR Solid State Contactor | Medium | Low | Extended | Extended | Minimal | Good | Fast | None | Excellent control with one second cycle time. |
| SCR Burst Firing | High | Low | Extended Longest | Longest | Minimal | Very Excellent | Very Fast | None | one second time base or variable time base unit. |
| SCR Phase Angle | High | Lowest | Extended | Longest | High | Excellent | Fastest | Current Limit | Required for tungsten elements, transformers, or for current limiting. |
| Saturable Core Reactor | Highest | Low | Extended | Longest | Minimal | Very Good | Fast | Current Limit | Cannot be turned full ON or OFF, inefficient. |

*Includes heater replacement and lost production.

Application Guide

Wiring Practices

This section of the Application Guide is devoted to thermal system wiring practices. In this section are general guidelines for successful integration of the different thermal system components—heaters, temperature sensors, temperature controllers and power controllers. This section **is not** a step-by-step, how-to manual. It is your responsibility to be sure your wiring is safe and meets the requirements of applicable agency standards along with national and local electrical codes. If you're unable to determine which method of wiring will best suit your needs, call your nearest Watlow Sales Representative. Their experience with all types of thermal systems makes them an invaluable source for advice. Sales offices are listed on the back cover of this catalog.

System wiring is divided into two main areas—signal wiring and power wiring. Signal wiring deals with input signals (generated by the temperature sensor) and output signals (generated by the temperature controller). Power wiring deals with supply power to the temperature and power controllers and the current that's ultimately delivered to the heating element.

Signal wiring is less straight forward than power wiring. Not only does it have to conform to circuit designs, but must also be installed in such a way as to minimize the negative effects of electrical noise present in any thermal system.

This section will start with wiring sensors to controllers and then wiring power controllers to temperature controllers. It also offers limit control wiring examples which provide a comprehensive system overview.

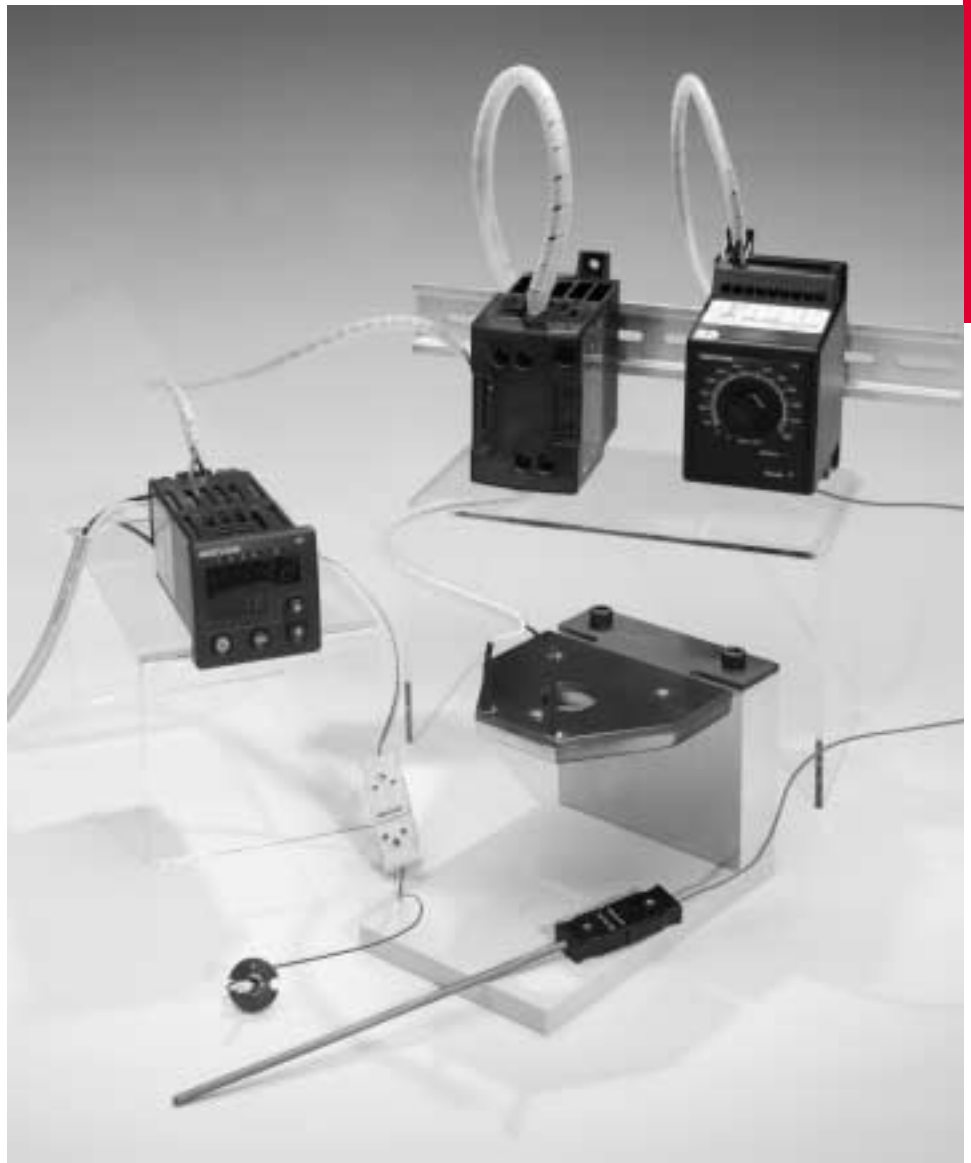

Wiring Practices for a Successful Control System

Not long ago the majority of industrial thermal systems were controlled by electrical/mechanical devices that were fairly immune to the negative effects of electrical noise. The shortest path for the wire was the best and only path. Noise resistant wiring

practices just weren't a concern. With the advent of today's electronic controllers, awareness of techniques to minimize the disrupting effects of electrical "noise" is critical.

Application Guide

Wiring Practices

Electrical Noise

What is Electrical Noise?

It is electrical signals which produce undesirable effects in the electronic circuits of the control system. The term "electrical noise" originated with AM radios when the extraneous "noise" heard in the speaker was

caused by lightning or other sources of electrical arcing. Electrical noise from all sources and its effects on controllers are very difficult to define, let alone give exact rules on how to prevent. Noise sensitivity is a function of more recent electronic controller designs. However, the majority of noise problems stem from crude wiring practices and techniques which

allow "coupling" or the transfer of electrical noise into the control circuit. An outstanding resource for information about wiring guidelines (source for this summary) is the **IEEE Standard No. 518-1982** and is available from IEEE, Inc., 345 East 47th Street, New York, NY 10017; phone number: 800-678-4333. Internet: www.ieee.org

When is Electrical Noise a Problem?

Symptoms resulting from an electrically noisy environment are difficult to predict. One common symptom is an erratic system, with no evidence of a

problem appearing consistently. Even worse, the system may exhibit several different symptoms.

Some other commonplace symptoms of noise-related problems are fluctuating digital indicators, blanked digital

indicators, control instability about set point and outputs turning on or off unexpectedly. Another "red flag" of electrical noise raises when high or low limits trip with no limit fault condition.

Why is Electrical Noise Sensitivity a Problem?

How accurately a controller can differentiate between desired system signals and electrical noise is a good indicator of its sensitivity to noise. In general, high power controllers such

as mechanical relays or mercury displacement relays have low noise sensitivity, while low power controllers that use electronic logic, especially those using integrated circuits, are more sensitive to noise. The development of all-electronic solid state con-

trollers has improved the accuracy of control and expanded immensely their capabilities, but they are more complex and operate at very low power levels. Electrical noise is more likely to affect them because of their lower operating power levels.

Where Does Electrical Noise Come From?

Our industrial world is full of equipment capable of generating many types of electrical noise. A typical noise source is any piece of equipment that can cause or produce very rapid or large amplitude changes in voltage or current when turned on and off.

Noise Sources:

- Switches and relay contacts operating inductive loads such as motors, coils, solenoids and relays, etc.
- Thyristors or other semiconductor devices which are not burst fired (randomly-fired or phase angle-fired devices)
- All welding machinery
- Heavy current carrying conductors
- Fluorescent and neon lights
- Thermal voltages between dissimilar metals that influence the low voltage thermocouple input signal

- Chemical voltage produced by electrolyte action between poorly connected leads and interconnect cables
- Thermal noise from increased ambient temperatures around the circuit electronics
- Noise could be introduced if the control circuit includes the option of a mechanical relay output and is used to switch high load currents over two or three amps. This presents a significant source for noise, including inductive noise from the coil and contact arcing, depending on how much power is brought inside the controller

Application Guide

Wiring Practices

Electrical Noise

Continued

How Does Electrical Noise Get In?

The control circuitry must be considered in terms of the total system in an electrically noisy environment. The sensor input and power output lines as well as the power source line, all have the potential to couple or link the control circuit to a noise source.

Depending on the type of electrical noise and its intensity, noise can be coupled to other equipment by one of the following four methods:

1. Common Impedance Coupling

Common impedance coupling occurs when two circuits share a common conductor or impedances (even common power sources). A frequently used common impedance coupling is the practice of using one long common neutral or ground wire. An example would be five relay contacts operating five separate solenoids where the switching runs dependently. The return lines from all the solenoids are connected together and run back to the power source with one conductor.

This example of impedance coupling has a tendency to induce noise in circuits that do not have noise, or to amplify the noise from one or more of the

circuits sharing the common line. The best way to prevent this type of coupling is to eliminate the common line and use independent leads for each return circuit.

Another noise problem associated with the common impedance coupling is a ground loop. Ground loops occur when multiple paths exist for ground currents. Not only should the solenoid return lines be run as independent leads to the same electrical potential point, but they should also be terminated at the same physical point. In the same manner, safety ground lines should be returned to the same electrical and physical point. Safety ground (chassis ground) should never carry return currents.

2. Magnetic Inductive Coupling

Magnetic (inductive) coupling generally appears where there are wires running parallel or in close vicinity to each other. This happens when the wires from several different circuits are bundled together in order to make the system wiring appear neat. However, without proper wire separation and shielding, magnetic coupling will introduce severe noise problems into sensitive (low voltage

level) circuits. The best way to eliminate magnetic (inductive) coupling is to run leads from separate circuits in separate bundles, taking special care to keep ac* (high voltage level) wires separated from dc (low voltage level) wires. If it is at all possible, twisted pair leads and shielding cables (with termination of shield at the controller end only) should be used to reduce magnetic coupling of noise.

3. Electrostatic (Capacitive) Coupling

Electrostatic (capacitive) coupling appears where wires are running parallel with each other, similar to magnetic coupling. That is where the similarities end. Electrostatic, or capacitive, coupling is a function of the distance the wires run parallel to

each other, the distance between the wires and wire diameter. The most effective way of reducing electrostatic (capacitive) coupling is to properly shield the wire runs. Again, separation of wires carrying ac* (high voltage level) and those carrying dc (low voltage level) signals will effectively reduce the noise in sensitive circuits.

4. Electromagnetic (Radiation) Coupling

Electromagnetic (radiation) coupling occurs when the control circuit is very close to a high energy source that is capable of magnetic or electrostatic induction of a voltage. Common

sources of such radiation are TV or radio broadcasting towers. This type of interference is not experienced often because the circuit must be very close to the source. It is also difficult to eliminate if present, because shielding must be 100 percent complete.

***Note:** Special attention should be given to the ac power line because it is a source of unusual types of noise-related problems in control circuits. Phenomena such as unbalanced power lines, brownouts, power surges, lightning and other "dirty" input power can cause the ac power supply line to fluctuate and momentarily drop below the operating specifications for the ac input to the control circuitry. When the type of noise on the ac supply line can be identified as purely electrical noise and it does not cause the line voltage level to drop, line filtering devices can be purchased to take care of the problems. However, if power surges, brownouts, inadequate wire size, etc., are causing the ac line voltage to drop below the levels recommended by the control circuit manufacturer, the only solution is to correct the wiring size or the voltage distribution.

Application Guide

Wiring Practices

Helpful Wiring Guidelines

Overview

A quick review shows that electrical noise can enter the control circuit through four different paths:

1. Input signal lines (most sensitive)
2. Output signal lines
3. Power input lines
4. Radiation (least likely to be a problem)

Potential Noise Entry Paths

Ref. 117

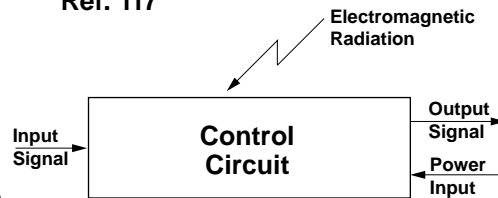

The sensitivity or susceptibility to noise coupling will be different among the four paths and may even vary on the same path, depending on the type of electrical noise and its intensity.

Following simple wiring techniques will greatly decrease the control system's sensitivity to noise.

Physical Separation and Wire Routing

- Physical separation and wire routing must be given careful consideration in planning the layout of the system. For example, ac power supply lines should be bundled together and kept physically separate from input signal lines (very low power level). Keep all switched output signal lines (high voltage level) separate from current control loop signals (low voltage level). If lines must cross, do so at right angles.

Power and Signal Line Separation Example Ref. 118

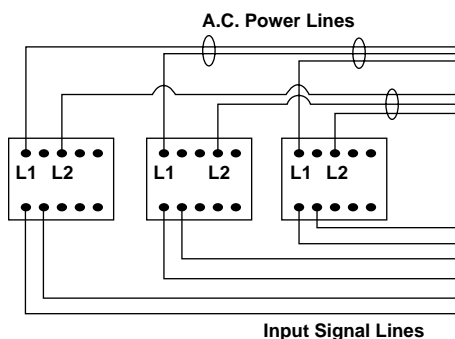

- Another important practice is to look at the system layout and identify electrical noise sources such as solenoids, relay contacts, motors, etc., and where they are physically located. Then use as much caution as possible to route the wire bundles and cables away from these noise sources. The control circuits, of course, should also be physically separated from these sources.
- Whenever possible, low level signal lines should be run unbroken from signal source to the control circuit.
- Shielded cables should be used for all low power signal lines to protect from magnetic and electrostatic coupling of noise. Some simple pointers are as follows:
 - A. Connect the shield to the control circuit common end only. Never leave the shield unconnected at both ends. Never connect both ends of the shield to a common.
 - B. If the shield is broken at a terminal and the line continues, the shield must be reconnected to maintain shield continuity.
 - C. If the shield is used as a signal return (conductor) no electrostatic shielding can be assumed. If this must be done, use a triaxial cable (electrostatically shielded coaxial cable).
 - D. Twisted wire should be used any time control circuit signals must travel over two feet, or when they are bundled in parallel with other wires.
 - E. Acceptable twisted wire should have at least 12 to 16 twists per foot.

Twisted Pair Wire Ref. 120



Shielded Twisted Pair Wire Ref. 119

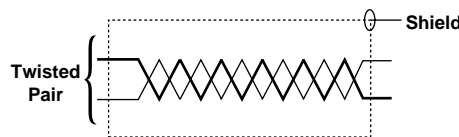

Application Guide

Wiring Practices

Helpful Wiring Guidelines

Continued

Wire Gauge

The size or gauge of wire should be selected by calculating the maximum circuit current and choosing the gauge fulfilling that requirement. Using sizes a great deal larger than required will generally increase the likelihood of electrostatic (capacitance) coupling of noise.

Ground Loops

In an optimized system, ground loops would be eliminated in the entire control system. There are obvious loops which can be spotted by studying the “as-built” wiring diagram. There are also the not-so-obvious ground loops that result from the technique of connecting internal circuits common in the manufacturer’s equipment. An example would be if a control circuit is designed to work

with a grounded sensor input. By obtaining an internal schematic for the control equipment, identifying how common connections are done, and transferring that information to the “as-built” wiring diagram, one can easily determine if ground loops are created.

Ground Each Chassis

Ground the chassis of each piece of equipment in the system. Connect each individual chassis to the overall equipment chassis immediately adjacent to that piece and tie all major chassis ground terminals together with one lead (usually green wire) to ground at one single point.

Chassis Grounds vs. Commons

Do not confuse chassis grounds (safety ground) with control circuit commons or with ac supply lines L2 (return or neutral line). Each return system wiring must be kept separate. Make sure the chassis ground (safety) is never used as a conductor to return circuit current.

Earth Ground

Ensure optimum controller performance by having a good earth ground. Some controllers have specific grounding requirements. Refer to the specific controller manuals for terminal connection instructions.

No Daisy Chains

For best noise immunity, avoid daisy chaining ac power (or return) lines or output signal (or return) lines to multiple control circuits. Use direct, individual pairs of lines from the power source to each device requiring ac power. Avoid paralleling L1 (power lead) and L2 (return lead) to load power solenoids, contactors and control circuits. If L1 (power lead) is used to switch a load, the L2 line (return lead) will have the same switched voltage potential and could couple unwanted noise into a control circuit.

Get It at the Source

Other techniques to prevent problems include eliminating the noise at, or as close to the source as possible. These include the following:

- A Quencharc® may be placed across the terminals of devices such as relays, relay contacts, solenoids, motors, etc., to filter out noise generated by such devices. A Quencharc® is a simple RC suppression device using a 0.1µf 600V~(ac), non-polar capacitor in series with a 100 ohm, ½ watt resistor. This device can be used on ac or dc circuits to effectively dampen noise at its source. Any dc relay solenoids, etc., should have a

diode with the proper voltage rating for the circuit wired in reverse across the coil to suppress back emf.

- A “MOV” (Metal Oxide Varistor) can be installed across the ac line to limit voltage “spikes” that occur on the ac supply lines as a result of lightning strikes, switching large motors, etc. The MOV is available in several varieties for 115 or 220V~(ac) lines. The MOV dissipates the voltage “spikes” to ground. However, MOVs have a limited life, because repeated action deteriorates the device.
- An Islatrol®, and other similar power line filters are designed to carry the power for the control

circuit and at the same time buffer the control circuit from ac line noise. Devices like an Islatrol® use media (electromagnetic filtering), other than electric circuits to filter out electrical noise. Care must be taken in matching the power capabilities of the filter with the power demands of the circuit.

- The ultimate protection is an “un-interruptable power supply” (UPS). This device senses the ac power line, and when it fluctuates, a battery powered 60Hz inverted circuit takes over supplying power within one-half to one cycle of the ac line.

Quencharc® is a registered trademark of ITW Pakton.

Islatrol® is a registered trademark of Control Concepts Corporation.

Application Guide

Wiring Practices

Input Power Wiring

Microprocessors require a clean environment to operate to their full potential. A clean environment means on one level an environment that is free of excessive dust, moisture and other airborne pollutants. But primarily it means a clean source of input power from which to base all its operations.

Clean power is simply a steady, noise-free line voltage source that meets the rating specifications of the equipment using it. Without clean power to the integrated circuitry, any microprocessor chip is doomed to malfunction.

The recommendations provided here for you are ways to achieve an acceptable level of clean input power protection. In almost all cases these guidelines will remove the potential for input power problems. If you've applied these measures and still do not get results, please feel free to call us at the factory.

For Clean Input Power:

Do—

- Do Keep line filters as close to the controller as possible to minimize the area of interference (noise pick up).
- Do Use twisted pair wire and possibly shielded wire from line filters to the controller to keep the line "clean."
- Do Keep low power controller wires physically separated as far as possible from line voltage wires. Also, keep all controller wiring separate from other nearby wiring. Physical separation is extremely effective for avoiding noise. A 300 mm (12 in.) minimum separation is usually effective.
- Do Use a common mode, differential mode or a combination of the two filters wherever power may have electrical noise.
- Do Cross other wiring at 90 degrees whenever crossing lines is unavoidable.
- Do Have a computer ground line separate from all other ground lines. The computer ground line should ideally terminate at the ground rod where the electrical service is grounded.

Don't—

- Don't Connect computer ground to safety ground or any other ground points in the electrical system—except at the ground rod.
- Don't Mount relays or switching devices close to a microprocessor controller.
- Don't Run wires carrying line voltage with signal wires (sensor communications or other low power lines) going to the control.
- Don't Use conduit for computer ground.
- Don't Connect ground to a metal control case if the control is mounted in grounded enclosure to prevent ground loops.
- Don't Fasten line filters with metal cases to more than one ground. This prevents ground loops and maintains filter effectiveness.

How to Check for Ground Loops

To check for ground loops, disconnect the ground wire at the ground termination. Use a volt/ohm meter to measure the resistance from the wire to the point where it was connected. The ohmmeter should read a high ohm value. If you have a low ohm value across this gap, there is at least one ground loop present in your system.

If you find continuity, begin looking for the ground loops. Disconnect grounds in the system one at a time, checking for continuity after each disconnection. When the meter reads continuity "open," you've eliminated the ground loop(s). As you reconnect grounds, keep making the continuity test. It is possible to reconnect a ground loop.

Application Guide

Wiring Practices

Input Power Wiring

Continued

Line Filtering Configurations for Controllers

These three diagrams show filter configurations for removing input power noise.

Combination Differential/Common Mode Filter Diagram
Ref. 121

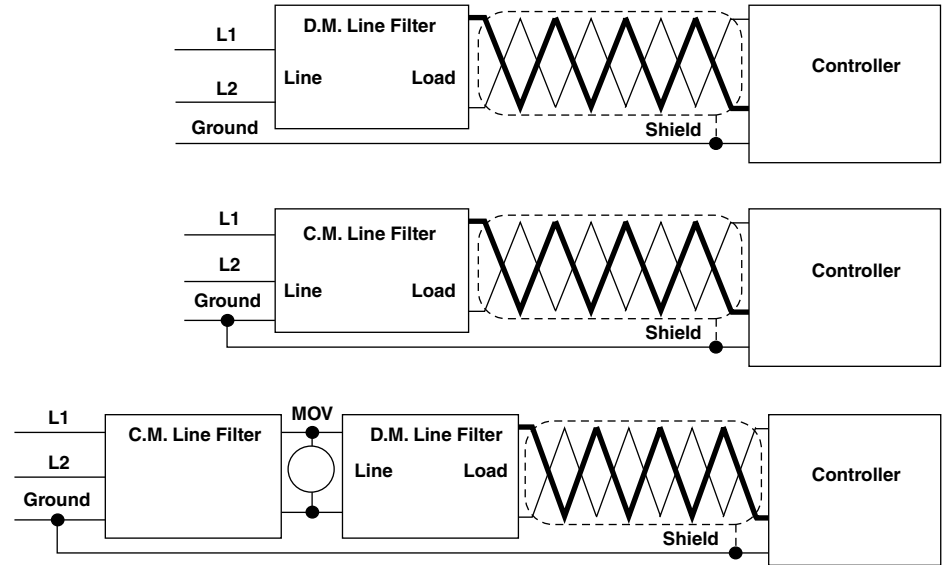

Note: Keep filters 300 mm (12 in.) or less from the control. Minimize the line distance where noise can be re-introduced to the control.

Note: Don't Fasten line filters with metal cases to more than one ground. This prevents ground loops and maintains filter effectiveness.

For very dirty or critical applications—use microcomputer-regulated power supply or uninterruptible power supply.

Noise Suppression Devices Available

Noise suppression devices are available from Watlow and local Watlow distributors.

Ref. 122

| Item | Electrical Ratings | Part Number |
|------------|-------------------------|----------------|
| Quencharc® | 0.1µ f, 600V~(ac), 100Ω | 0804-0147-0000 |

Internet sites:

- www.cor.com
- www.aerovox.com
- www.filternetworks.com
- www.control-concepts.com

Application Guide

Wiring Practices

Output Wiring

While there is always an ideal way to wire each output type, we can't cover every situation. However, we can provide the most important points. Not just so the wiring looks neat, but so it's electrically "clean" as well. Incorrect wiring may cause damage to system components or threaten system reliability. Such problems take time and cost money.

Wiring Temperature Controllers to Power Controllers

These diagrams cover connecting temperature controller output signals to power controls.

Note: Some controllers offer built-in RC noise suppression. Check the product ordering information.

How to Wire the Mechanical Relay Control Output

Electromechanical Relay Output Wiring Example

Ref. 123

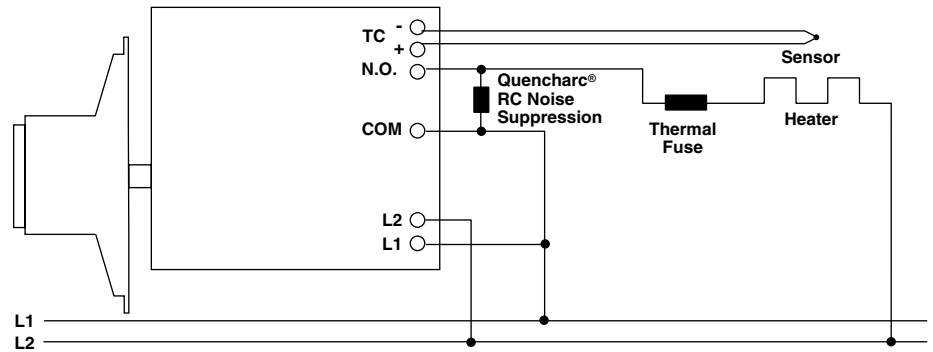

How the Mechanical Relay Output Works

The normally open (N.O.) and common (COM) contacts of the mechanical relay operate as switch contacts. When a temperature controller calls for heat, the contacts will close and there will be continuity.

Mechanical Relay Output Tips and Special Considerations

1. The specified current rating for mechanical relays is usually at 120/240V~(ac) and can be rated differently at other voltages.
2. In UL® applications, the relay output may be derated with ambient temperature.

How to Wire the Solid State Relay Control Output

Solid State Output Wiring Example

Ref. 124

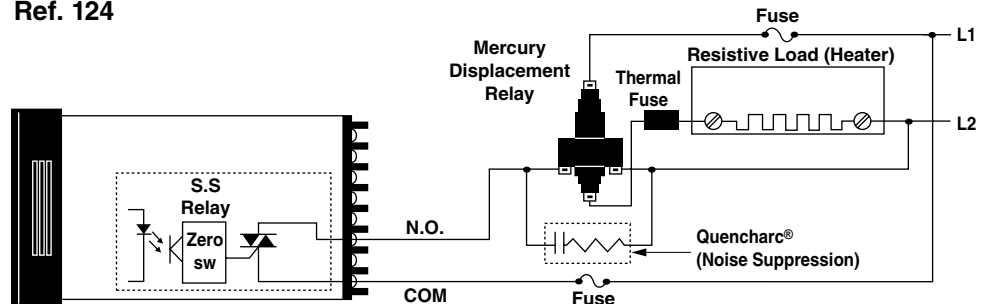

How the Solid State Relay Output Works

The COM and N.O. terminals of the solid state relay output operate like a switch. When a temperature controller is calling for heat, there will be ac power conducted between the terminals.

Solid State Relay Output Tips and Special Considerations

1. Make sure the load device meets the "minimum load current" specifica-

tion but does not exceed the maximum current rating for the solid state output device.

2. Watlow solid state relays will switch only ac voltages.
3. Always provide overtemperature limit protection to circumvent the shorted solid state relay output failure mode.

UL® is a registered trademark of Underwriter's Laboratories, Inc.

Application Guide

Wiring Practices

Output Wiring

Continued

How the Solid State Switched DC Works

When a heating control calls for temperature rise, the switched dc output (a transistor) turns on, developing a positive voltage across the output terminals, which turns on the solid state contactor and then the load.

How to Wire the Solid State Switch Control Output

Solid State Switched DC Wiring Examples Ref. 125

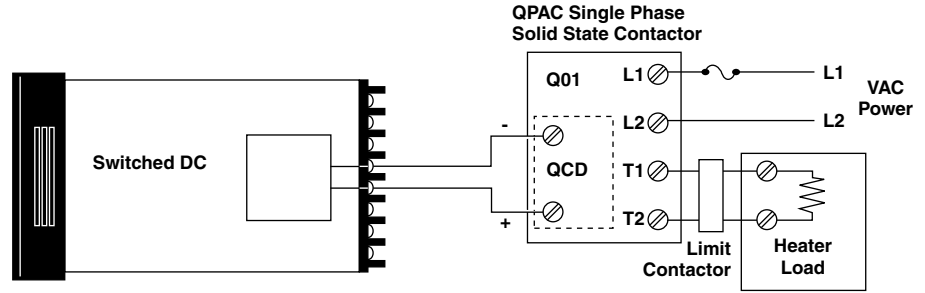

Solid State Switched DC Tips and Special Considerations

1. Be sure to route output wiring from the temperature controller to the load power switching device in as short a run as possible while avoiding any wires carrying line voltage.

2. Be sure the input specifications for the solid state relay are compatible with the specification of the Watlow solid state switch output.

How the Process Output Works

When the controller calls for an increase in the actual process value (heat, flow or pressure, etc.), and when that actual value is outside the controller's proportional band, the process output turns full on. With a 0-5V=(dc) process output, full on measures 5 volts; with 4-20mA, full on measures 20mA.

As the actual process value moves toward set point and enters the proportional band, the output signal decreases proportionately. Ideally, the system will proceed to set point without overshoot. As the system stabilizes at set point, the process output signal becomes constant at a value between 0-5V=(dc) or 4-20mA. System thermal characteristics and control PID settings combine to determine the final, stable value of the process output signal.

How to Wire the Process Output

Process Output Wiring Examples Ref. 126

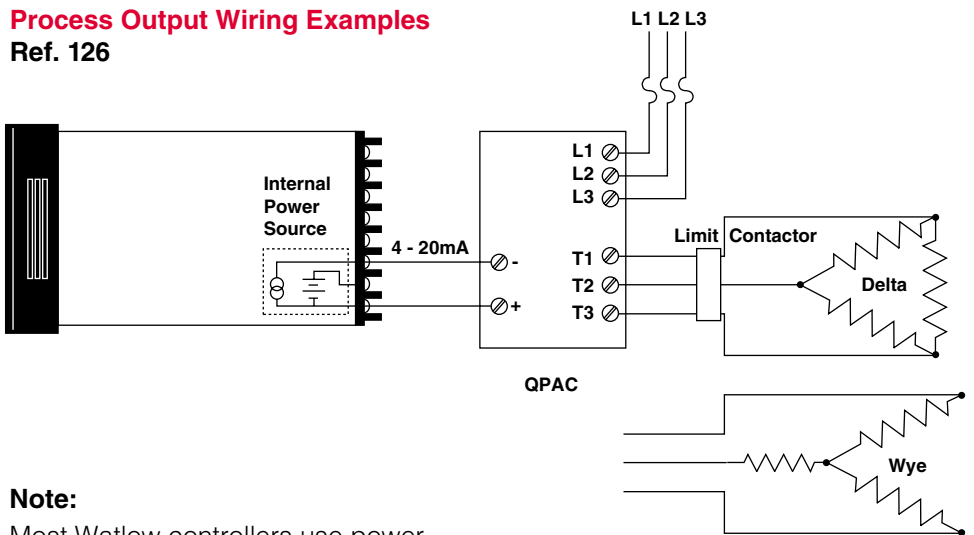

Note:

Most Watlow controllers use power from their internal supply to power process outputs.

Application Guide

Wiring Practices

SCR Wiring—Tips and Special Considerations

Warning

Whenever installing or working on an SCR, always disconnect the power. Carefully read the accompanying instructions for information specific to the particular SCR being installed/serviced. Failure to do so could cause serious injury or death.

The following are general installation/service tips and considerations to make your SCR use easier, better and longer lasting.

Fusing

Two types of fuses are required to properly protect SCRs. Branch circuit fuses and semiconductor fuses should be used together in the circuit to ensure short circuit and overload protection.

Semiconductor fuses are very fast and will blow in less than one millisecond on very high fault currents, i.e. short circuits. They are made up of parallel silver links packed in a low temperature silica sand. When they blow, the silver links produce heat and melt the sand which forms a glass seal to stop the arc produced from the blown links. Semiconductor fuses are rated by the I^2T value which is determined by current squared times time (I^2T). If the I^2T rating of the fuse is at or below the rating of the SCR, it will protect the SCR from a short circuit in the load or wiring. Semiconductor fuses do not have a defined overload rating, therefore, they are not legal or safe to use for branch circuit protection. A semiconductor fuse will pass 400 to 500 percent of its base current rating for an hour or more.

Branch circuit fuses or circuit breakers are different from semiconductor fuses in that they are sized by their overload rating. These fuses are required to protect the wiring and the load from partial overload conditions. A branch circuit fuse should clear in one minute at 125 percent of its base rating.

Branch circuit fuses should be sized such that they pass only 80 percent of its base. The way to insure this is to pick a fuse rating that is 125 percent of the connected load, or the next available fuse size up to a maximum of 160 percent of connected load.

The semiconductor fuse base rating can be determined as shown above or it can be rated to the power controller provided that the I^2T rating of the SCR is not exceeded.

Mounting Location

Selecting a mounting location for an SCR is important. They're larger than mechanical relays and MDRs of comparable ratings. More importantly, SCRs must be mounted in such a way to insure adequate ventilation. Excessive ambient heat will dramatically shorten an SCR's life.

Enclosures

It's a good idea to mount SCRs in protective enclosures meeting NEMA ratings to prevent the possibility of electrical shock and the accumulation of contaminants. Enclosure must be vented to allow for cooling with vents located above the top of the heatsinks.

Vibration

Any location experiencing excessive vibration should be mounted using industry standard shock mounting techniques. Excessive vibration can also affect wire connections. Make sure the connectors used can withstand the vibration and remain tight.

Wiring Considerations

Wire should be sized to meet NEC and local electrical codes. Ambient operating conditions should be taken into account.

Cable Routing and Connection

Route all large power cables to the SCR in such a manor to allow access for inspection, I^2t fuse replacement and other maintenance not requiring removal of the SCR. Wire connectors should be conveniently located to allow use of a wrench for tightening.

Heat generated by the flow of electricity will heat and expand the wire and the connector. This could cause resistance to increase, generating even more heat. To minimize the effects of heat, use spring, or "Belleville" washers on all electrical junctions to insure a tight connection. Additionally, all connections should have an electrical compound applied to improve both thermal and electrical conductivity.

Application Guide

Wiring Practices

SCR Wiring—Tips and Special Considerations (con't)

After the first 48 hours of use, re-tighten all wire connections to specifications. Additionally, an installation design which directs air from cooling fans to pass over wire connectors will help cool the connections and improve reliability.

Power Disconnect and SCR Protection

Disconnect means should be provided through circuit breaker, fused disconnect or fuses. These should be installed ahead of the SCR. The I²t fuses used in the SCR are designed to prevent surge or transient currents from damaging the semi-conductors in the SCR. They are oversized to prevent nuisance fuse blowing and, for this reason, cannot be used or relied upon for steady state overload protection.

Noise Considerations

Industrial environments and phase angle fired SCRs can produce electrical noise that could create signal error in the sensor wiring or temperature control. If unacceptable levels of electric noise are present, use MOV, resistor-capacitor networks and other noise suppression devices.

Heater Type vs. Firing Method

Many loads that change resistance over time and temperature require phase angle firing. Most other loads can use burst firing. Consult with the heating element manufacturer for most appropriate firing method recommendation.

Temperature Control Compatibility

Not all temperature controllers will work with all SCRs and vice versa. Be sure the type of temperature controller is suitable for use with your selected SCR. Consult the manufacturer for details on compatibility.

Control Panels

Available in a variety of configurations and levels of sophistication, control panels, and their smaller versions control boxes, contain all temperature and power controlling devices necessary for a thermal system. This includes a separate temperature limit control circuit. All that is required for operation is mounting, power supply and load connections, and connecting the temperature and limit sensors to their respective controllers. Enclosures can be specified to meet application environments.

Control Panel Guide

Control panels combine temperature, limit and power controllers in a self-contained enclosure, ready for mounting and hook-up. Control panels are generally for large thermal systems. Capacities range up to 1600 amps or more. Temperature, limit and power controllers are carefully matched to application requirements while enclosures feature NEMA ratings to match application environment. Control panels require four to five week lead times for shipment. Control panels can be made to comply with agency approvals and can have agency certification when required. Applications include large industrial furnaces, petrochemical plants and heat treating furnaces.

Control Boxes

With capacities up to 50 amps, control boxes provide temperature, limit and power controller packages in a NEMA rated enclosure. Availability is fast with a five to 10 working day lead time for shipment on most models. Popular temperature, limit and power controller options make control boxes a hassle free “control system” alternative to specing, buying and assembling the individual components.

Application Guide

Reference Data

This section of the Application Guide contains information helpful in understanding the thermodynamics of heating systems.

The first half of this section contains technical references, conversion tables, formulas and other data used in solving heating problems. The second half contains examples of applications to illustrate how to draw all the information in this Application Guide together for solving heating problems.

Space limits don't permit this information to be all encompassing. If you're unable to find the information you need, we suggest you consult additional Watlow reference materials and engineering textbooks specific to the areas you're working on. These are listed at the end of this section. If your need is more immediate, please call your nearest Watlow Representative. Sales offices are listed on the back cover of this guide.

Celsius to Fahrenheit/Fahrenheit to Celsius—Ref. 127

| to °C | °F/°C | to °F | to °C | °F/°C | to °F | to °C | °F/°C | to °F | to °C | °F/°C | to °F |
|--------|-------|--------|-------|-------|-------|-------|-------|--------|-------|-------|--------|
| -184.4 | -300 | NA | 65.6 | 150 | 302.0 | 315.6 | 600 | 1112.0 | 565.6 | 1050 | 1922.0 |
| -178.9 | -290 | NA | 71.1 | 160 | 320.0 | 321.1 | 610 | 1130.0 | 571.1 | 1060 | 1940.0 |
| -173.3 | -280 | NA | 76.7 | 170 | 338.0 | 326.7 | 620 | 1148.0 | 576.7 | 1070 | 1958.0 |
| -167.8 | -270 | -454.0 | 82.2 | 180 | 356.0 | 332.2 | 630 | 1166.0 | 582.2 | 1080 | 1976.0 |
| -162.2 | -260 | -436.0 | 87.8 | 190 | 374.0 | 337.8 | 640 | 1184.0 | 587.8 | 1090 | 1994.0 |
| -156.7 | -250 | -418.0 | 93.3 | 200 | 392.0 | 343.3 | 650 | 1202.0 | 593.3 | 1100 | 2012.0 |
| -151.1 | -240 | -400.0 | 98.9 | 210 | 410.0 | 348.9 | 660 | 1220.0 | 598.9 | 1110 | 2030.0 |
| -145.6 | -230 | -382.0 | 104.4 | 220 | 428.0 | 354.4 | 670 | 1238.0 | 604.4 | 1120 | 2048.0 |
| -140.0 | -220 | -364.0 | 110.0 | 230 | 446.0 | 360.0 | 680 | 1256.0 | 610.0 | 1130 | 2066.0 |
| -134.4 | -210 | -346.0 | 115.6 | 240 | 464.0 | 365.6 | 690 | 1274.0 | 615.6 | 1140 | 2084.0 |
| -128.9 | -200 | -328.0 | 121.1 | 250 | 482.0 | 371.1 | 700 | 1292.0 | 621.1 | 1150 | 2102.0 |
| -123.3 | -190 | -310.0 | 126.7 | 260 | 500.0 | 376.7 | 710 | 1310.0 | 626.7 | 1160 | 2120.0 |
| -117.8 | -180 | -292.0 | 132.2 | 270 | 518.0 | 382.2 | 720 | 1328.0 | 632.2 | 1170 | 2138.0 |
| -112.2 | -170 | -274.0 | 137.8 | 280 | 536.0 | 387.8 | 730 | 1346.0 | 637.8 | 1180 | 2156.0 |
| -106.7 | -160 | -256.0 | 143.3 | 290 | 554.0 | 393.3 | 740 | 1364.0 | 643.3 | 1190 | 2174.0 |
| -101.1 | -150 | -238.0 | 148.9 | 300 | 572.0 | 398.9 | 750 | 1382.0 | 648.9 | 1200 | 2192.0 |
| -95.6 | -140 | -220.0 | 154.4 | 310 | 590.0 | 404.4 | 760 | 1400.0 | 654.4 | 1210 | 2210.0 |
| -90.0 | -130 | -202.0 | 160.0 | 320 | 608.0 | 410.0 | 770 | 1418.0 | 660.0 | 1220 | 2228.0 |
| -84.4 | -120 | -184.0 | 165.6 | 330 | 626.0 | 415.6 | 780 | 1436.0 | 665.6 | 1230 | 2246.0 |
| -78.9 | -110 | -166.0 | 171.1 | 340 | 644.0 | 421.1 | 790 | 1454.0 | 671.1 | 1240 | 2264.0 |
| -73.3 | -100 | -148.0 | 176.7 | 350 | 662.0 | 426.7 | 800 | 1472.0 | 676.7 | 1250 | 2282.0 |
| -67.8 | -90 | -130.0 | 182.2 | 360 | 680.0 | 432.2 | 810 | 1490.0 | 682.2 | 1260 | 2300.0 |
| -62.2 | -80 | -112.0 | 187.8 | 370 | 698.0 | 437.8 | 820 | 1508.0 | 687.8 | 1270 | 2318.0 |
| -56.7 | -70 | -94.0 | 193.3 | 380 | 716.0 | 443.3 | 830 | 1526.0 | 693.3 | 1280 | 2336.0 |
| -51.1 | -60 | -76.0 | 198.9 | 390 | 734.0 | 448.9 | 840 | 1544.0 | 698.9 | 1290 | 2354.0 |
| -45.6 | -50 | -58.0 | 204.4 | 400 | 752.0 | 454.4 | 850 | 1562.0 | 704.4 | 1300 | 2372.0 |
| -40.0 | -40 | -40.0 | 210.0 | 410 | 770.0 | 460.0 | 860 | 1580.0 | 710.0 | 1310 | 2390.0 |
| -34.4 | -30 | -22.0 | 215.6 | 420 | 788.0 | 465.6 | 870 | 1598.0 | 715.6 | 1320 | 2408.0 |
| -28.9 | -20 | -4.0 | 221.1 | 430 | 806.0 | 471.1 | 880 | 1616.0 | 721.1 | 1330 | 2426.0 |
| -23.3 | -10 | 14.0 | 226.7 | 440 | 824.0 | 476.7 | 890 | 1634.0 | 726.7 | 1340 | 2444.0 |
| -17.8 | 0 | 32.0 | 232.2 | 450 | 842.0 | 482.2 | 900 | 1652.0 | 732.2 | 1350 | 2462.0 |
| -12.2 | 10 | 50.0 | 237.8 | 460 | 860.0 | 487.8 | 910 | 1670.0 | 737.8 | 1360 | 2480.0 |
| -6.7 | 20 | 68.0 | 243.3 | 470 | 878.0 | 493.3 | 920 | 1688.0 | 743.3 | 1370 | 2498.0 |
| -1.1 | 30 | 86.0 | 248.9 | 480 | 896.0 | 498.9 | 930 | 1706.0 | 748.9 | 1380 | 2516.0 |
| 4.4 | 40 | 104.0 | 254.4 | 490 | 914.0 | 504.4 | 940 | 1724.0 | 754.4 | 1390 | 2534.0 |

CONTINUED

Application Guide

Reference Data

| to °C | °F/°C | to °F | to °C | °F/°C | to °F | to °C | °F/°C | to °F | to °C | °F/°C | to °F |
|-------|-------|--------|--------|-------|--------|--------|-------|--------|--------|-------|--------|
| 10.0 | 50 | 122.0 | 260.0 | 500 | 932.0 | 510.0 | 950 | 1742.0 | 760.0 | 1400 | 2552.0 |
| 15.6 | 60 | 140.0 | 265.6 | 510 | 950.0 | 515.6 | 960 | 1760.0 | 765.6 | 1410 | 2570.0 |
| 21.1 | 70 | 158.0 | 271.1 | 520 | 968.0 | 521.1 | 970 | 1778.0 | 771.1 | 1420 | 2588.0 |
| 26.7 | 80 | 176.0 | 276.7 | 530 | 986.0 | 526.7 | 980 | 1796.0 | 776.7 | 1430 | 2606.0 |
| 32.2 | 90 | 194.0 | 282.2 | 540 | 1004.0 | 532.2 | 990 | 1814.0 | 782.2 | 1440 | 2624.0 |
| 37.8 | 100 | 212.0 | 287.8 | 550 | 1022.0 | 537.8 | 1000 | 1832.0 | 787.8 | 1450 | 2642.0 |
| 43.3 | 110 | 230.0 | 293.3 | 560 | 1040.0 | 543.3 | 1010 | 1850.0 | 793.3 | 1460 | 2660.0 |
| 48.9 | 120 | 248.0 | 298.9 | 570 | 1058.0 | 548.9 | 1020 | 1868.0 | 798.9 | 1470 | 2678.0 |
| 54.4 | 130 | 266.0 | 304.4 | 580 | 1076.0 | 554.4 | 1030 | 1886.0 | 804.4 | 1480 | 2696.0 |
| 60.0 | 140 | 284.0 | 310.0 | 590 | 1094.0 | 560.0 | 1040 | 1904.0 | 810.0 | 1490 | 2714.0 |
| 815.6 | 1500 | 2732.0 | 954.4 | 1750 | 3182.0 | 1093.3 | 2000 | 3632.0 | 1232.2 | 2250 | 4082.0 |
| 821.1 | 1510 | 2750.0 | 960.0 | 1760 | 3200.0 | 1098.9 | 2010 | 3650.0 | 1237.8 | 2260 | 4100.0 |
| 826.7 | 1520 | 2768.0 | 965.6 | 1770 | 3218.0 | 1104.4 | 2020 | 3668.0 | 1243.3 | 2270 | 4118.0 |
| 832.2 | 1530 | 2786.0 | 971.1 | 1780 | 3236.0 | 1110.0 | 2030 | 3686.0 | 1248.9 | 2280 | 4136.0 |
| 837.8 | 1540 | 2804.0 | 976.7 | 1790 | 3254.0 | 1115.6 | 2040 | 3704.0 | 1254.4 | 2290 | 4154.0 |
| 843.3 | 1550 | 2822.0 | 982.2 | 1800 | 3272.0 | 1121.1 | 2050 | 3722.0 | 1260.0 | 2300 | 4172.0 |
| 848.9 | 1560 | 2840.0 | 987.8 | 1810 | 3290.0 | 1126.7 | 2060 | 3740.0 | 1265.6 | 2310 | 4190.0 |
| 854.4 | 1570 | 2858.0 | 993.3 | 1820 | 3308.0 | 1132.2 | 2070 | 3758.0 | 1271.1 | 2320 | 4208.0 |
| 860.0 | 1580 | 2876.0 | 998.9 | 1830 | 3326.0 | 1137.8 | 2080 | 3776.0 | 1276.7 | 2330 | 4226.0 |
| 865.6 | 1590 | 2894.0 | 1004.4 | 1840 | 3344.0 | 1143.3 | 2090 | 3794.0 | 1282.2 | 2340 | 4244.0 |
| 871.1 | 1600 | 2912.0 | 1010.0 | 1850 | 3362.0 | 1148.9 | 2100 | 3812.0 | 1287.8 | 2350 | 4262.0 |
| 876.7 | 1610 | 2930.0 | 1015.6 | 1860 | 3380.0 | 1154.4 | 2110 | 3830.0 | 1293.3 | 2360 | 4280.0 |
| 882.2 | 1620 | 2948.0 | 1021.1 | 1870 | 3398.0 | 1160.0 | 2120 | 3848.0 | 1298.9 | 2370 | 4298.0 |
| 887.8 | 1630 | 2966.0 | 1026.7 | 1880 | 3416.0 | 1165.6 | 2130 | 3866.0 | 1304.4 | 2380 | 4616.0 |
| 893.3 | 1640 | 2984.0 | 1032.2 | 1890 | 3434.0 | 1171.1 | 2140 | 3884.0 | 1310.0 | 2390 | 4334.0 |
| 898.9 | 1650 | 3002.0 | 1037.8 | 1900 | 3452.0 | 1176.7 | 2150 | 3902.0 | 1315.6 | 2400 | 4352.0 |
| 904.4 | 1660 | 3020.0 | 1043.3 | 1910 | 3470.0 | 1182.2 | 2160 | 3920.0 | 1321.1 | 2410 | 4370.0 |
| 910.0 | 1670 | 3038.0 | 1048.9 | 1920 | 3488.0 | 1187.8 | 2170 | 3938.0 | 1326.7 | 2420 | 4388.0 |
| 915.6 | 1680 | 3056.0 | 1054.4 | 1930 | 3506.0 | 1193.3 | 2180 | 3956.0 | 1332.2 | 2430 | 4406.0 |
| 921.1 | 1690 | 3074.0 | 1060.0 | 1940 | 3524.0 | 1198.9 | 2190 | 3974.0 | 1337.8 | 2440 | 4424.0 |
| 926.7 | 1700 | 3092.0 | 1065.6 | 1950 | 3542.0 | 1204.4 | 2200 | 3992.0 | 1343.3 | 2450 | 4442.0 |
| 932.2 | 1710 | 3110.0 | 1071.1 | 1960 | 3560.0 | 1210.0 | 2210 | 4010.0 | 1348.9 | 2460 | 4460.0 |
| 937.8 | 1720 | 3128.0 | 1076.7 | 1970 | 3578.0 | 1215.6 | 2220 | 4028.0 | 1354.5 | 2470 | 4478.0 |
| 943.3 | 1730 | 3146.0 | 1082.2 | 1980 | 3596.0 | 1221.1 | 2230 | 4046.0 | 1360.0 | 2480 | 4496.0 |
| 948.9 | 1740 | 3164.0 | 1087.8 | 1990 | 3614.0 | 1226.7 | 2240 | 4064.0 | 1365.6 | 2490 | 4515.0 |

Application Guide

Reference Data

Ref. 128

| Temperature Scale | Convert to by... |
|-------------------|--------------------------------------|
| Fahrenheit | °F = 1.8°C + 32° |
| Celsius | °C = 5/9 (°F - 32°) |
| Rankine | °R = 1.8K + 0.6° °R = °F + 460° |
| Kelvin | K = 5/9 (°R - 0.6°) K = °C + 273° |

Note: The Kelvin scale uses no "°" symbol.

Ratings of Listed Heater Voltages Operated on Other Voltages—Ref. 129

| kW Rating of Heater | 120 Volts | | 240 Volts | | | 480 Volts | |
|---------------------------|---------------------------------------|--------------|--------------|--------------|--------------|--------------|--------------|
| | Output kW of Heater When Operated On: | | | | | | |
| | 110 Volts | 115 Volts | 208 Volts | 220 Volts | 230 Volts | 440 Volts | 460 Volts |
| 1.0 | 0.84 | 0.92 | 0.75 | 0.84 | 0.92 | 0.84 | 0.92 |
| 2.0 | 1.69 | 1.84 | 1.50 | 1.69 | 1.84 | 1.69 | 1.84 |
| 3.0 | 2.53 | 2.76 | 2.25 | 2.53 | 2.76 | 2.53 | 2.76 |
| 4.0 | 3.36 | 3.67 | 3.00 | 3.36 | 3.68 | 3.36 | 3.68 |
| 4.5 | 3.78 | 4.13 | 3.38 | 3.78 | 4.14 | 3.78 | 4.14 |
| 5.0 | 4.20 | 4.59 | 3.5 | 4.2 | 4.6 | 4.2 | 4.6 |
| 7.5 | 6.30 | 6.89 | 5.6 | 6.3 | 6.9 | 6.3 | 6.9 |
| 10.0 | | | 7.5 | 8.4 | 9.2 | 8.4 | 9.2 |
| 12.5 | | | 9.4 | 10.5 | 11.5 | 10.5 | 11.5 |
| 15.0 | | | 11.3 | 12.6 | 13.8 | 12.6 | 13.8 |
| 20.0 | | | 15.0 | 16.9 | 18.4 | 16.9 | 18.4 |
| 25.0 | | | 18.8 | 21.0 | 23.0 | 21.0 | 23.0 |
| 50.0 | | | 37.6 | 42.0 | 46.0 | 42.0 | 46.0 |
| 75.0 | | | 56.3 | 63.0 | 69.0 | 63.0 | 69.0 |
| 100.0 | | | 75.1 | 84.0 | 92.0 | 84.0 | 92.0 |

Equation:

$$W_{\text{NEW}} = W_{\text{RATED}} \left(\frac{V_{\text{NEW}}}{V_{\text{RATED}}} \right)^2$$

Application Guide

Reference Data

Conversion Factors—Ref. 130

| To Convert To... | | Multiply... | By... |
|---|-------------------------------------|------------------------|----------------------------------|
| Atmospheres | (atm) | Bar | 0.9869 |
| Atmospheres | (atm) | Inches Mercury | (in Hg) 0.03342 |
| Atmospheres | (atm) | Pounds/square inch | (psi) 0.06805 |
| Atmospheres | (atm) | Torr | 0.001316 |
| Bar | | Atmospheres | (atm) 1.0133 |
| Bar | | Pounds/square inch | (psi) 0.06895 |
| British Thermal Units | (Btu) | Joules | (J) 0.000948 |
| British Thermal Units | (Btu) | Kilowatt-hours | (kWh) 3412 |
| British Thermal Units | (Btu) | Watt-hours | (Wh) 3.412 |
| British Thermal Units/hour | (Btu/h) | Kilocalories/hour | (kcal/h) 3.969 |
| British Thermal Units/hour | (Btu/h) | Watts | (W) 3.412 |
| British Thermal Units—inches hour-square foot—°F | (Btu—in) (h-ft ² —°F) | Watts/meter—°C | (W/m—°C) 6.933 |
| British Thermal Units/pound | (Btu/lb) | Kilojoules/kilogram | (kJ/kg) 0.4299 |
| British Thermal Units/pound—°F | (Btu/lb—°F) | Kilojoules/kilogram—°C | (kJ/kg—°C) 0.2388 |
| Calories | (cal) | Joules | (J) 0.2388 |
| Centimeters | (cm) | Feet | (ft) 30.48 |
| Centimeters | (cm) | Inches | (in) 2.54 |
| Centimeters/second | (cm/s) | Feet/minute | (fpm) 0.508 |
| Cubic centimeters | (cm ³ or cc) | Cubic feet | (ft ³) 28,320 |
| Cubic centimeters | (cm ³ or cc) | Cubic inches | (in ³) 16.39 |
| Cubic centimeters | (cm ³ or cc) | Milliliters | (ml) 1.0 |
| Cubic feet | (ft ³) | Cubic meters | (m ³) 35.32 |
| Cubic feet | (ft ³) | Gallons, U.S. | (gal) 0.1337 |
| Cubic feet | (ft ³) | Liters | (l) 0.03532 |
| Cubic feet/minute | (cfm) | Cubic meters/hour | (m ³ /h) 0.5885 |
| Cubic feet/minute | (cfm) | Cubic meters/second | (m ³ /s) 2119 |
| Cubic feet/minute | (cfm) | Liters/second | (l/s) 2.119 |
| Cubic inches | (in ³) | Cubic centimeters | (cm ³ or cc) 0.061 |
| Cubic meters | (m ³) | Gallons, U.S. | (gal) 0.003785 |
| Cubic meters | (m ³) | Liters | (l) 0.001 |
| Cubic meters | (m ³) | Cubic feet | (ft ³) 0.02832 |
| Cubic meters/hour | (m ³ /h) | Cubic feet/minute | (cfm) 1.699 |
| Cubic meters/hour | (m ³ /h) | Gallons/minute | (gpm) 0.2271 |
| Cubic meters/second | (m ³ /s) | Cubic feet/minute | (cfm) 0.000472 |
| Feet | (ft) | Centimeters | (cm) 0.03281 |
| Feet | (ft) | Meters | (m) 3.281 |
| Feet/minute | (fpm) | Centimeters/second | (cm/s) 1.969 |
| Feet/minute | (fpm) | Meters/second | (m/s) 196.9 |
| Gallons, Imperial | | Gallons, U.S. | (gal) 0.8327 |

CONTINUED 

Application Guide

Reference Data

Conversion Factors

| To Convert To... | | Multiply... | | By... |
|-----------------------------|-----------------------|--------------------------------|-----------------------|-----------|
| Gallons, U.S. | (gal) | Cubic feet | (ft ³) | 7.481 |
| Gallons, U.S. | (gal) | Cubic meters | (m ³) | 264.2 |
| Gallons, U.S. | (gal) | Gallons, Imperial | | 1.201 |
| Gallons, U.S. | (gal) | Liters | (l) | 0.2642 |
| Gallons/minute | (gpm) | Cubic meters/hour | (m ³ /h) | 4.403 |
| Gallons/minute | (gpm) | Liters/second | (l/s) | 15.85 |
| Grams | (g) | Ounces | (oz) | 28.35 |
| Grams | (g) | Pounds | (lb) | 453.6 |
| Grams/cubic centimeter | (g/cm ³) | Kilograms/cubic meter | (kg/m ³) | 0.001 |
| Grams/cubic centimeter | (g/cm ³) | Pounds/cubic foot | (lb/ft ³) | 0.01602 |
| Grams/cubic centimeter | (g/cm ³) | Pounds/cubic inch | (lb/in ³) | 27.68 |
| Inches | (in) | Centimeters | (cm) | 0.3937 |
| Inches | (in) | Millimeters | (mm) | 0.03937 |
| Inches Mercury | (in Hg) | Atmospheres | (atm) | 29.92 |
| Inches Mercury | (in Hg) | Torr | | 25.4 |
| Joules | (J) | British Thermal Units | (Btu) | 1055 |
| Joules | (J) | Calories | (cal) | 4.187 |
| Joules | (J) | Watt-hours | (Wh) | 3600 |
| Joules/second | (J/s) | British Thermal Units/hour | (Btu/h) | 0.2931 |
| Joules/second | (J/s) | Watts | (W) | 1 |
| Kilocalories/hour | (kcal/h) | Btu/hour | (Btu/h) | 0.252 |
| Kilograms | (kg) | Pounds | (lb) | 0.4536 |
| Kilograms/cubic meter | (kg/m ³) | Grams/cubic centimeter | (g/cm ³) | 1000 |
| Kilograms/cubic meter | (kg/m ³) | Pounds/cubic foot | (lb/ft ³) | 16.02 |
| Kilograms/square centimeter | (kg/cm ²) | Pounds/square inch | (psi) | 0.07031 |
| Kilojoules | (kJ) | Watt-hours | (Wh) | 3.6 |
| Kilojoules/kilogram | (kJ/kg) | British Thermal Units/pound | (Btu/lb) | 2.326 |
| Kilojoules/kilogram—°C | (kJ/kg—°C) | British Thermal Units/pound—°F | (Btu/lb—°F) | 4.187 |
| Kilometers/hour | (km/h) | Miles/hour | (mph) | 1.609 |
| Kilopascals | (kPa) | Pounds/square inch | (psi) | 6.895 |
| Kilowatts | (kW) | British Thermal Units/hour | (Btu/h) | 0.0002931 |
| Kilowatts | (kW) | Watts | (W) | 0.001 |
| Kilowatt-hours | (kWh) | British Thermal Units | (Btu) | 0.0002931 |
| Kilowatt-hours | (kWh) | Watt-hours | (Wh) | 0.001 |
| Liters | (l) | Cubic Feet | (ft ³) | 28.32 |
| Liters | (l) | Cubic Meters | (m ³) | 1000 |
| Liters | (l) | Gallons, U.S. | (gal) | 3.785 |
| Liters/second | (l/s) | Cubic feet/minute | (cfm) | 0.4719 |
| Liters/second | (l/s) | Gallons/minute | (gpm) | 0.06309 |

CONTINUED

Reference Data

Application Guide

Reference Data

Conversion Factors

| To Convert To... | | Multiply... | | By... |
|-------------------------|-----------------------|---|---|-----------|
| Meters | (m) | Feet | (ft) | 0.3048 |
| Meters/second | (m/s) | Feet/minute | (fpm) | 0.00508 |
| Miles/hour | (mph) | Kilometers/hour | (km/h) | 0.6215 |
| Millimeters | (mm) | Inches | (in) | 25.4 |
| Newtons/square meter | (N/m ²) | Pounds/square inch | (psi) | 6,895 |
| Ounces | (oz) | Grams | (g) | 0.035274 |
| Pounds | (lb) | Grams | (g) | 0.002205 |
| Pounds | (lb) | Kilograms | (kg) | 2.205 |
| Pounds/cubic foot | (lb/ft ³) | Grams/cubic centimeter | (g/cm ³) | 62.43 |
| Pounds/cubic foot | (lb/ft ³) | Kilograms/cubic meter | (kg/m ³) | 0.06243 |
| Pounds/cubic inch | (lb/in ³) | Grams/cubic centimeter | (g/cm ³) | 0.03613 |
| Pounds/square inch | (psi) | Bar | | 14.504 |
| Pounds/square inch | (psi) | Kilograms/square centimeter | (kg/cm ²) | 14.22 |
| Pounds/square inch | (psi) | Kilopascals | (kPa) | 0.145 |
| Pounds/square inch | (psi) | Newtons/square meter | (N/m ²) | 0.000145 |
| Square centimeters | (cm ²) | Square feet | (ft ²) | 929 |
| Square centimeters | (cm ²) | Square inches | (in ²) | 6.452 |
| Square feet | (ft ²) | Square centimeters | (cm ²) | 0.001076 |
| Square feet | (ft ²) | Square meters | (m ²) | 10.76 |
| Square inches | (in ²) | Square centimeters | (cm ²) | 0.155 |
| Square meters | (m ²) | Square feet | (ft ²) | 0.0929 |
| Torr | | Inches Mercury | (in. Hg) | 0.03937 |
| Torr | | Pounds/square inch | (psi) | 51.71 |
| Watts | (W) | British Thermal Units/hour | (Btu/h) | 0.2931 |
| Watts | (W) | Joules/second | (J/s) | 1 |
| Watt-hours | (Wh) | British Thermal Units | (Btu) | 0.2931 |
| Watt-hours | (Wh) | Joules | (J) | 0.0002778 |
| Watt-hours | (Wh) | Kilojoules | (kJ) | 0.2778 |
| Watts/meter—°C | (W/m—°C) | British Thermal Units— inches hour-square foot—°F | (Btu— in) (h-ft ² —°F) | 0.1442 |
| Watts/square centimeter | (W/cm ²) | Watts/square inch | (W/in ²) | 0.155 |
| Watts/square inch | (W/in ²) | Watts/square centimeter | (W/cm ²) | 6.452 |

Application Guide

Reference Data

Commonly Used Geometric Areas And Volumes

Areas and Dimensions of Plane Figures

Ref. 131

The following illustrations show the areas of plane figures, the surfaces of solids, and the volumes of solids.

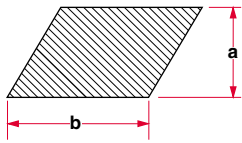

Square, Rectangle, Parallelogram

A = area
 A = ab
 Note that dimension a is measured at right angles to line b.

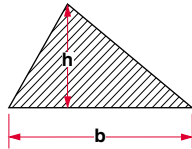

Triangle

A = area
 $A = \frac{bh}{2}$

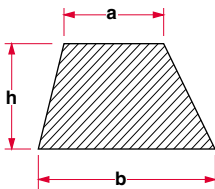

Trapezoid

A = area
 $A = \frac{(a + b)h}{2}$

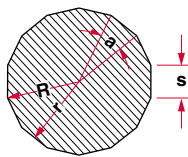

Regular Polygon

A = area
 n = number of sides
 s = length of side
 $a = \frac{360^\circ}{n} \div n$
 $A = \frac{nsr}{2} = \frac{ns}{2} \sqrt{\frac{R^2 - s^2}{4}}$

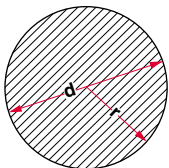

Circle

A = area
 C = circumference
 $A = \pi r^2 = \pi \frac{d^2}{4}$
 $C = 2\pi r = \pi d$

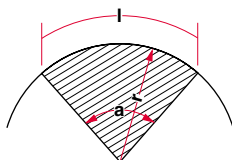

Circular Sector

A = area
 l = length of arc
 a = angle, in degrees
 r = radius
 $l = ra \cdot 3.14 \pi$
 $A = \frac{1}{2} r l$
 $a = \frac{57.3 l}{r}$

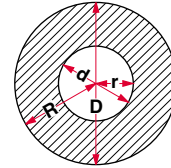

Circular Ring

A = area
 $A = \pi (R^2 - r^2)$
 $= 0.7854 (D^2 - d^2)$

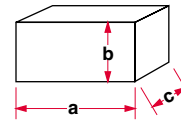

Cube or Square Prism

V = volume
 A = area of surface
 $V = abc$
 $A = 2ab + 2ac + 2bc$

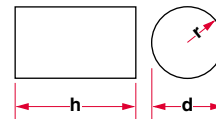

Cylinder

V = volume
 S = area of cylindrical surface
 $V = \pi r^2 h = \frac{\pi d^2 h}{4}$
 $S = 6.28rh = 3.14dh$
 Total area A of cylindrical surface and end surfaces:
 $A = 6.28r(r + h)$
 $= 3.14d(\frac{1}{2}d + h)$

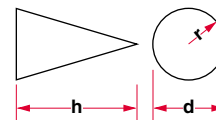

Cone

V = volume
 A = area of conical surface
 $V = \frac{1}{3} \pi r^2 h$
 $A = \pi r \sqrt{r^2 + h^2}$

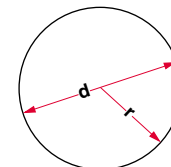

Sphere

V = volume
 A = area of surface
 $V = \frac{4\pi r^3}{3} = \frac{\pi d^3}{6}$
 $A = 4\pi r^2 = \pi d^2$

Application Guide

Reference Data

Physical Properties of Solids, Liquids and Gases

Properties of Non-Metallic Solids—Ref. 132

| Material | *Density lb./ft ³ | Specific Heat Btu lb.-°F | *Thermal Conductivity Btu-in hr.-ft ² -°F | Melting Point °F (Lowest) | Latent Heat of Fusion Btu/lb. |
|-------------------------------------|---------------------------------|--------------------------------|---|------------------------------------|--|
| Allyl, Cast | 82.5 | 0.55 | 12.1 | | |
| Alumina 96% | 232 | 0.20 | 110.9 | 3812 | |
| Alumina 99.9% | 249 | 0.20 | 270 | 3812 | |
| Aluminum Silicate (Lava Grade A) | 149 | 0.2 | 9.1 | 3690 | |
| Aluminum Nitride | 199 | 0.19 | 1179 | 3992 | |
| Amber | 65.6 | | | | |
| Asbestos | 36 | 0.25 | 0.44 | | |
| Ashes | 40-45 | 0.2 | 0.49 | | |
| Asphalt | 65 | 0.4 | 1.2 | 250± | 40 |
| Bakelite Resin, Pure | 74-81 | 0.3-0.4 | | | |
| Barium Chloride | 240 | 0.10 | | 1697 | |
| Beeswax | 60 | | 1.67 | 144 | 75 |
| Boron Nitride (Compacted) | 142 | 0.33 | 125 | 5430 | |
| Brick, Common Clay | 100 | 0.23 | 5 | | |
| Brick, Facing/Building & Mortars | 140 | 0.22 | 8 | | |
| Calcium Chloride | 157 | 0.17 | | 1422 | 72 |
| Carbon | 138 | 0.20 | 165 | 6700 | |
| Carnauba Wax | 62.4 | 0.8 | | | |
| Cement, Portland Loose | 94 | 0.19 | 2.04 | | |
| Cerafelt Insulation | 3 | 0.25 @ 1000° | 1.22 | | |
| Ceramic Fiber | 10-15 | 0.27 | *** | | |
| Chalk | 112-175 | 0.215 | 5.76 | | |
| Charcoal Wood | 17.5-36 | 0.242 | 0.612 | | |
| Chrome Brick | | 0.17 | 9.6 | | |
| Clay | 90±10 | 0.224 | 9 | 3160 | |
| Coal (Course Anthracite) | 80 | 0.32 | 11 | | |
| Coal Tars | 78 | 0.35-0.45 | | | |
| Coke | 62-88 | 0.265 | | | |
| Concrete (Cinder) | 100 | 0.16 | 5.3 | | |
| Concrete (Stone) | 144 | 0.156 | 9.5 | | |
| Cordierite (AISI Mag 202) | 131 | 0.35 | 9.12 | 2680 | |
| Cork | 13.5 | 0.5 | 0.36 | | |
| Cotton (Flax, Hemp) | 92.4 | 0.31 | 0.41 | | |
| Delrin | 88 | 0.35 | 1.56 | | |
| Diamond | 219 | 0.147 | 13872 | | |
| Earth, Dry & Packed | 94 | 0.44 | 0.9 | | |
| Ethyl Cellulose | 67-74 | 0.32-0.46 | | | |
| Fiberglass | 0.75 | | 0.28 | | |
| Microlite Duct Insulation | | | | | |
| Fiberglass | 3 | | 0.26 | | |
| Spin-Glas 1000 Insulation | | | | | |

* At or near room temperature

** Thermal conductivity will decrease with age and use

To convert to kg/m³ multiply lb/ft³ by 16.02

To convert to kJ/kg multiply Btu/lb by 2.326

To convert to kJ/kg-°C multiply

Btu/lb-°F by 4.187

To convert to W/m-°C multiply

Btu -in/hr-ft²-°F by 0.1442

CONTINUED 

Application Guide

Reference Data

Physical Properties of Solids, Liquids and Gases

Continued

| Material | *Density lb./ft ³ | Specific Heat $\frac{\text{Btu}}{\text{lb.}\cdot^{\circ}\text{F}}$ | *Thermal Conductivity $\frac{\text{Btu}\cdot\text{in}}{\text{hr.}\cdot\text{ft}^2\cdot^{\circ}\text{F}}$ | Melting Point °F (Lowest) | Latent Heat of Fusion Btu/lb. |
|--------------------------------------|---------------------------------|--|--|------------------------------------|--|
| Firebrick, Fireclay | 137-150 | 0.243 | 6.6 | 2900 | |
| Firebrick, Silica | 144-162 | 0.258 | 7.2 | 3000 | |
| Flourspar | | 0.21 | | | |
| Forsterite (AISI Mag 243) | 175 | | 25.5 | 3470 | |
| Garnet | | 0.176 | | | |
| Glass | 165 | 0.20 | 5.4 | 2200 | |
| Granite | 160-175 | 0.192 | 13-28 | | |
| Graphite | 130 | 0.20 | 1.25 | 1202 (sublimation) | |
| Ice | 57 | 0.46 | 15.36 | 32 | |
| Isoprene (Nat'l Rubber) | 58 | 0.48 | 1.0 | | |
| Limestone | 130-175 | 0.217 | 3.6-9 | 1472 | |
| Litharge | | 0.055 | | 1627 | |
| Magnesia | 225 | 0.234 | 0.48 | 5070 | |
| Magnesite Brick | 159 | 0.222 | 10.8-30 | | |
| Magnesium Oxide Before Compaction | 147 | 0.21 | 3.6 | 5165 | |
| After Compaction | 190 | 0.21 | 14.4 | 5165 | |
| Magnesium Silicate | 175 | | 15.6 | | |
| Marble | 150-175 | 0.21 | 14.4 | | |
| Marinite I @ 400°F | 46 | 0.29 | 0.89 | | |
| Melamine Formaldehyde | 93 | 0.4 | 3 | | |
| Mica | 185 | 0.20 | 3 | | |
| Nylon Fibers | 72 | 0.4-0.5 | | | |
| Paper | 58 | 0.45 | 0.82 | | |
| Paraffin | 56 | 0.70 | 1.56 | 133 | 63 |
| Phenolic Resin, Cast | 84 | 0.3-0.4 | 1.1 | | |
| Phenolic Formaldehyde | 78-92 | 0.38-0.42 | | | |
| Phenolic, Sheet or Tube Laminated | 78 | 0.3-0.5 | 2.4 | | |
| Pitch, Hard | 83 | | | 300± | |
| Plastics: | | | | | |
| ABS | 69-76 | 0.35 2.28 | 1.32 | | |
| Acrylic | 69-74 | 0.34 | 1.0 | | |
| Cellulose Acetate | 76-83 | 0.3-0.5 | 1.2-2.3 | | |
| Cellulose Acetate Butyrate | 74 | 0.3-0.4 | 1.2-2.3 | | |
| Epoxy | 66-88 | 0.25-0.3 | 1.2-2.4 | | |
| Fluoroplastics | 131-150 | 0.28 | 1.68 | | |
| Nylon | 67-72 | 0.3-0.5 | 1.68 | | |
| Phenolic | 85-124 | 0.35 | 1.02 | | |
| Polycarbonate | 74-78 | 0.3 | 1.38 | | |
| Polyester | 66-92 | 0.2-0.35 | 3.96-5 | | |
| Polyethylene | 57-60 | 0.54 | 2.28 | | |
| | 3.48 | | | | |
| Polyimides | 90 | 0.27-0.31 | 2.5-6.8 | | |
| Polypropylene | 55-57 | 0.46 | 1.72 | | |

Reference Data

* At or near room temperature

** Thermal conductivity will decrease with age and use

To convert to kg/m³ multiply lb/ft³ by 16.02

To convert to kJ/kg multiply Btu/lb by 2.326

To convert to kJ/kg-°C multiply

Btu/lb-°F by 4.187

To convert to W/m-°C multiply

Btu-in/hr-ft²-°F by 0.1442

CONTINUED

Application Guide

Reference Data

Physical Properties of Solids, Liquids and Gases

Continued

| Material | *Density lb./ft ³ | Specific Heat Btu lb.-°F | *Thermal Conductivity | Melting Point °F (Lowest) | Latent Heat of Fusion Btu/lb. |
|--|---------------------------------|-----------------------------------|-----------------------------------|------------------------------------|--|
| | | | Btu-in hr.-ft ² -°F | | |
| Plastics: | | | | | |
| Polystyrene | 66 | 0.32 | 0.36-0.96 | | |
| Polyvinyl Chloride Acetate | 72-99 | 0.2-0.3 | 0.84-1.2 | | |
| Porcelain | 145-155 | 0.26 | 6-10 | | |
| Potassium Chloride | 124 | 0.17 | | 1454 | |
| Potassium Nitrate | 132 | 0.26 | | 633 | |
| Quartz | 138 | 0.26 | 9.6 | 3137 | |
| Rock Salt | | 0.219 | | 1495 | |
| Rubber Synthetics | 58 | 0.40 | 1.0 | | |
| Sand, Dry | 88-100 | 0.191 | 2.26 | | |
| Silica (fused) | 124 | 0.316 | 10.0 | 3137 | |
| Silicon Carbide | 112-125 | 0.20-0.23 | 866 | 4892 (sublimation) | |
| Silicone Nitride | 197 | 0.16 | 208 | 3452 (sublimation) | |
| Silicone Rubber | 78 | 0.45 | 1.5 | | |
| Soapstone | 162-174 | 0.22 | 11.3 | | |
| Sodium Carbonate | 135 | 0.30 | | 520 | |
| Sodium Chloride | 135 | 0.22 | | 1474 | |
| Sodium Cyanide | 94 | 0.30 | | 1047 | |
| Sodium Hydroxide Bath (75% NaOH and Mixed Salts) | 110 | 0.28 | | 550 | 72 |
| Sodium Nitrate | 141 | 0.29 | | 584 | |
| Sodium Nitrite | 135 | 0.30 | | 520 | |
| Sodium/Potassium | | | | | |
| Nitrate Baths: | | | | | |
| Draw Temp 275 | | | | | |
| Solid | 132 | 0.32 | | 275 | 94 |
| Liquid | 110 | 0.37 | 2.4± @ 600°F | | |
| Draw Temp 430 | | | | | |
| Solid | 130 | 0.29 | | 430 | 49 |
| Liquid | 115 | 0.38 | 2.4± @ 600°F | | |
| Soil, Dry Including Stones | 127 | 0.40 | 3.6 | | |
| Steatite | 162 | 0.20 | 17.4 | 2500 | |
| Stone | | 0.20 | | | |
| Stone, Sandstone | 130-150 | 0.22 | | | |
| Sugar | 105 | 0.30 | | 320 | |
| Sulphur | 125 | 0.203 | 1.8 | 230 | 17 |
| Tallow | 60 | | | 90± | |
| Teflon® | 135 | 0.25 | 1.7 | | |
| Urea, Formaldehyde | 97 | 0.4 | | | |
| Vinylidene | 107 | 0.32 | | | |
| Vinylite | 73 | 0.29 | | | |
| Wood, Oak | 50 | 0.57 | 1.2 | | |
| Wood, Pine | 34 | 0.67 | 0.9 | | |
| Zirconia | 368 | 0.12 | 17.3 | 4892 | |

* At or near room temperature

** Thermal conductivity will decrease with age and use

To convert to kg/m³ multiply lb/ft³ by 16.02

To convert to kJ/kg multiply Btu/lb by 2.326

To convert to kJ/kg-°C multiply

Btu/lb-°F by 4.187

To convert to W/m-°C multiply

Btu-in/hr-ft²-°F by 0.1442

Teflon® is a registered trademark of E.I. du Pont de Nemours & Company.

Application Guide

Reference Data

Physical Properties of Solids, Liquids and Gases

Continued

Properties of Metals—Ref. 133

| Material | Density lb./ft ³ | Specific Heat Btu lb.-°F | *Thermal Conductivity Btu-in hr.-ft ² -°F | Melting Point °F (Lowest) | Latent Heat of Fusion Btu/lb. | Thermal Expansion in/in/°F X10 ⁻⁶ |
|--------------------------------|--------------------------------|-----------------------------------|---|------------------------------------|--|---|
| Aluminum 1100-0 | 169 | 0.24 | 1536 | 1190 | 169 | 13.1 |
| Aluminum 2024 | 173 | 0.24 | 1344 | 935 | 167 | 12.6 |
| Antimony | 413 | 0.049 | 131 | 1166 | 69 | 5.0 |
| Babbitt-Lead Base | 640 | 0.039 | 165.6 | 470 | | 10.9 |
| Babbitt-Tin Base | 462 | 0.071 | 278.4 | 465 | | |
| Barium | 225 | 0.068 | | 1562 | 24 | 10.0 |
| Beryllium | 113.5 | 0.052 | 1121.0 | 2345 | 58 | 6.6 |
| Bismuth | 610 | 0.031 | 59 | 520 | 22.4 | 7.4 |
| Boron | 144 | 0.309 | | 4172 | 898 | 4.6 |
| Brass (80-20) | 535 | 0.091 | 82 | 1700± | | |
| Brass (70-30) | 525 | 0.10 | 672 | 1700± | | 10.6 |
| Brass (Yellow) | 529 | 0.096 | 828 | 1710 | | 11.2 |
| Bronze (75% Cu, 25% Sn) | 541 | 0.082 | 180 | 1832 | 75 | |
| Cadmium | 540 | 0.055 | 660 | 610 | 23.8 | 17.2 |
| Calcium | 96.7 | 0.149 | 912 | 1564 | 140 | 12.2 |
| Carbon | 138 | 0.165 | 173 | >6422 | | 2.3 |
| Carboloy (Cemented Carbide) | 875 | 0.052 | 420 636 | >6422 | | |
| Chromium | 450 | 0.11 | 484 | 2822 | 111.7 | 3.6 |
| Cobalt | 554 | 0.099 | 499 | 2696 | 115.2 | 6.9 |
| Constantan (55% Cu, 45% Ni) | 555 | 0.098 | | 2237-2372 | | 8.3 |
| Copper | 559 | 0.10 | 2688 | 1981 | 91 | 9.8 |
| German Silver | 537 | 0.109 | 168 204 | 1761 | 44.2 | 10.6 |
| Gold | 1203 | 0.030 | 2028 | 1945 | 29 | 7.9 |
| Incoloy 800 | 501 | 0.12 | 97 | 2475 | | 7.9 |
| Inconel 600 | 525 | 0.11 | 109 | 2470 | | 5.8 |
| Invar 36% Ni | 506 | 0.126 | 73 | 2600 | | 1.1 |
| Iron, Cast | 450 | 0.13 | 396 | 2300± | 40 | 6.0 |
| Iron, Wrought | 480 | 0.12 | 432 | 2800± | | |
| Lead | 708 | 0.032 | 240 | 620 | 9.8 | 16.4 |
| Linotype | 627 | 0.04 | | 480 | | |
| Lithium | 367 | 0.79 | 516 | 367 | 59 | 31 |
| Magnesium | 109 | 0.232 | 1092 | 1202 | 155 | 14.0 |
| Manganese | 463 | 0.115 | 80.6 | 2268 | 116 | 12.7 |
| Mercury | 844 | 0.033 | 60.8 | -38 | 5.0 | 33.8 |
| Molybdenum | 638 | 0.061 | 980 | 4750 | 126 | 2.9 |

Reference Data

CONTINUED 

* At or near room temperature

To convert to kg/m³ multiply lb/ft³ by 16.02

To convert to kJ/kg multiply Btu/lb by 2.326

To convert to kJ/kg-°C multiply Btu/lb-°F by 4.187

To convert to W/m-°C multiply Btu-in/hr-ft²-°F by 0.1442

Incoloy® and Inconel® are registered trademarks of the Special Metals Corporation.

Application Guide

Reference Data

Physical Properties of Solids, Liquids and Gases

Continued

| Material | Density lb./ft ³ | Specific Heat Btu lb.-°F | *Thermal Conductivity Btu-in hr.-ft ² -°F | Melting Point °F (Lowest) | Latent Heat of Fusion Btu/lb. | Thermal Expansion in/in/°F X10 ⁻⁶ |
|-----------------------------------|--------------------------------|--------------------------------|--|---------------------------------|----------------------------------|--|
| Monel® 400 | 551 | 0.11 | 151 | 2370 | | 6.4 |
| Muntz Metal (60% Cu, 40% Zn) | 523 | 0.096 | 852 | 1660 | | 11.5 |
| Nickel 200 | 554 | 0.11 | 468 | 2615 | 1335.8 | 7.4 |
| Nichrome (80% Ni, 20% Cr) | 524 | 0.11 | 104.4 | 2550 | 7.3 | 7.8 |
| Platinum | 1338 | 0.32 | 492 | 3225 | 49 | 4.9 |
| Potassium | 750 | 0.058 | 720 | 146 | 26.2 | 4.6 |
| Rhodium | 776 | 0.059 | 636 | 3570 | 90 | 4.7 |
| Silicon | 14.5 | 0.162 | 600 | 2570 | 709 | 4.2 |
| Silver | 655 | 0.057 | 2904 | 1760 | 38 | 10.8 |
| Sodium | 60 | 0.295 | 972 | 207 | 49.5 | 39 |
| Solder (50% Sn, 50% Pb) | 552 | 0.040 | 336 | 420 | 17 | 13.1 |
| Solder (60% Sn, 40% Pb) | 540 | 0.045 | 355 | 375 | 28 | 13.3 |
| Steel, Mild Carbon | 490 | 0.12 | 456 | 2760 | | 6.7 |
| Steel, Stainless 304, 316, 321 | 500 | 0.12 | 105.6 | 2550 | | 9.6 |
| Steel, Stainless 430 | 475 | 0.11 | 150 | 2650 | | 6.0 |
| Tantalum | 1036 | 0.036 | 372 | 5425 | 74.8 | 3.6 |
| Tin | 455 | 0.056 | 432 | 450 | 26.1 | 13.0 |
| Titanium | 283 | 0.126 | 111.6 | 3035 | 156.9 | 4.7 |
| Tungsten | 1200 | 0.032 | 1130 | 6170 | 79 | 2.5 |
| Type Metal (85% Pb, 15% Sb) | 670 | 0.040 | 180 | 500 | 14 | |
| Uranium | 1170 | 0.028 | 193.2 | 3075 | 22.5 | 7.4 |
| Zinc | 445 | 0.095 | 112 264 | 787 | 43.3 | 22.1 |
| Zirconium | 400 | 0.066 | 145 | 3350 | 108 | 3.2 |

* At or near room temperature

To convert to kg/m³ multiply lb/ft³ by 16.02

To convert to kJ/kg multiply Btu/lb by 2.326

To convert to kJ/kg-°C multiply Btu/lb-°F by 4.187

To convert to W/m-°C multiply Btu-in/hr-ft²-°F by 0.1442

Monel® is a registered trademark of the Special Metals Corporation.

Application Guide

Reference Data

Physical Properties

of Solids, Liquids and Gases Properties of Metals in Liquid State—Ref. 134

Continued

| Material | Melting Point °F (°C) | Heat of Fusion Btu/lb. | Temperature °F | Density lb./ft ³ | Specific Heat Capacity Btu lb.-°F | Thermal Conductivity Btu-in. hr.-ft ² -°F |
|--|--------------------------|---------------------------|--------------------------|--------------------------------|---|--|
| Aluminum | 1220.4 (660.2) | 173 | 1220 1292 1454 | 148.6 147.7 | 0.26 0.26 0.26 | 717 842 |
| Bismuth | 520 (271) | 21.6 | 572 752 1112 | 626.2 618.7 603.1 | 0.034 @ 520°F 0.0354 0.0376 | 119 107.4 107.4 |
| Cadmium | 609 (321) | 23.8 | 626 662 680 752 | 500 498.8 495 | 0.0632 0.0632 0.0632 0.0632 | 307.7 305 |
| Gold | 1945 (1063) | 26.9 | 2012 | 1076 | 0.0355 | |
| Lead | 621 (327.4) | 10.6 | 700 932 | 655.5 648.7 | 0.038 0.037 | 111.6 107.4 |
| Lithium | 354 (179) | 284.4 | 392 752 | 31.7 31 | 1.0 1.0 | 262 |
| Magnesium | 1204 (651) | 148 | 1204 1328 1341 | 98 94.3 | 0.317 0.321 | |
| Mercury | -38 (-38.9) | 5 | 32 212 320 392 | 833.6 818.8 | 0.03334 0.03279 0.03245 | 57 81 |
| Potassium | 147 (63.8) | 26.3 | 300 752 | 50.6 46.6 | 0.1901 0.1826 | 312 277.5 |
| Silver | 1761 (960.5) | 44.8 | 1761 1832 2000 | 580.6 578.1 574.4 | 0.0692 0.0692 0.0692 | |
| Sodium | 208 (97.8) | 48.7 | 212 400 752 | 57.9 56.2 53.3 | 0.331 0.320 0.301 | 596.5 556.8 493.8 |
| Tin | 449 (231.9) | 26.1 | 482 768 783 | 426.6 | 0.058 | 229.3 |
| Zinc | 787 (419.5) | 43.9 | 787 932 1112 | 432 425 | 0.12 0.117 | 400.6 394.8 |
| Solder 0.5 Sn, 0.5Pb 0.6 Sn, 0.4Pb | 421 (216) 375 (190.6) | 17 28 | | | 0.0556 0.0584 | |

Reference Data

To convert to kg/m³ multiply lb/ft³ by 16.02
 To convert to kJ/kg multiply Btu/lb by 2.326
 To convert to kJ/kg-°C multiply Btu/lb-°F by 4.187
 To convert to W/m-°C multiply Btu-in/hr-ft²-°F by 0.1442

Applications Guide

Reference Data Properties of Liquids—Ref. 135

Physical Properties of Solids, Liquids and Gases

Continued

| Substance | *Density lbs./ft ³ | Specific Heat Btu lb.-°F | *Thermal Conductivity Btu-in hr.-ft ² -°F | Boiling Point °F | Heat of Vaporization Btu/lb. |
|-----------------------------|----------------------------------|--------------------------------|---|------------------------|------------------------------------|
| Acetic Acid, 100% | 65.4 | 0.48 | 1.14 | 245 | 175 |
| Acetone, 100% | 49.0 | 0.514 | 1.15 | 133 | 225 |
| Allyl Alcohol | 55.0 | 0.665 | | 207 | 293 |
| Ammonia, 100% | 47.9 | 1.1 | 3.48 | -27 | 589 |
| Amyl Alcohol | 55.0 | 0.65 | | 280 | 216 |
| Aniline | 64.6 | 0.514 | 1.25 | 63 | 198 |
| Arochlor Oil | 89.7 | 0.28 | | 650 | |
| Brine-Calcium Chloride, 25% | 76.6 | 0.689 | 3.36 | | |
| Brine-Sodium Chloride, 25% | 74.1 | 0.786 | 2.88 | 220 | 730 |
| Butyl Alcohol | 45.3 | 0.687 | | 244 | 254 |
| Butyric Acid | 50.4 | 0.515 | | 345 | |
| Carbon Tetrachloride | 98.5 | 0.21 | | 170 | |
| Corn Syrup, Dextrose | 87.8 | 0.65± | | 231 | |
| Cottonseed Oil | 59.2 | 0.47 | 1.2 | | |
| Ether | 46.0 | 0.503 | 0.95 | 95 | 160 |
| Ethyl Acetate | 51.5 | 0.475 | | 180 | 183.5 |
| Ethyl Alcohol, 95% | 50.4 | 0.60 | 1.3 | | 370 |
| Ethyl Bromide | 90.5 | 0.215 | | 101 | 108 |
| Ethyl Chloride | 57.0 | 0.367 | | 54 | 166.5 |
| Ethyl Iodide | 113.0 | 0.161 | | 160 | 81.3 |
| Ethylene Bromide | 120.0 | 0.172 | | 270 | 83 |
| Ethylene Chloride | 71.7 | 0.299 | | 240 | 139 |
| Ethylene Glycol | 70.0 | 0.555 | | 387 | |
| Fatty Acid-Aleic | 55.4 | 0.7± | 1.1 | 547 | |
| Fatty Acid-Palmitic | 53.1 | 0.653 | 0.996 | 520 | |
| Fatty Acid-Stearic | 52.8 | 0.550 | 0.936 | 721 | |
| Fish, Fresh, Average | 55-65 | 0.76 | | | |
| Formic Acid | 69.2 | 0.525 | | 213 | 216 |
| Freon 11 | 92.1 | 0.208 | 0.600 | 74.9 | |
| Freon 12 | 81.8 | 0.232 | 0.492 | -21.6 | 62 |
| Freon 22 | 74.53 | 0.300 | 0.624 | -41.36 | |
| Fruit, Fresh, Average | 50-60 | 0.88 | | | |
| Glycerine | 78.7 | 0.58 | 1.97 | 556 | |
| Heptane | 38.2 | 0.49 | | 210 | 137.1 |
| Hexane | 38.2 | 0.6 | | 155 | 142.5 |

CONTINUED 

* At or near room temperature.

** Average value shown. Boils at various temperatures within the distillation range for the material. Verify exact value from application originator.

To convert to kg/m³ multiply lb/ft³ by 16.02

To convert to kJ/kg multiply Btu/lb by 2.326

To convert to kJ/kg-°C multiply Btu/lb-°F by 4.187

To convert to W/m-°C multiply Btu-in/hr-ft²-°F by 0.1442

Applications Guide

Reference Data

Physical Properties of Solids, Liquids and Gases

Continued

| Substance | *Density lbs./ft ³ | Specific Heat Btu lb.-°F | *Thermal Conductivity Btu-in hr.-ft ² -°F | Boiling Point °F | Heat of Vaporization Btu/lb. |
|---------------------------|----------------------------------|--------------------------------|--|---------------------|---------------------------------|
| Honey | | 0.34 | | | |
| Hydrochloric Acid, 10% | 66.5 | 0.93 | | 221 | |
| Ice | 56 | 0.5 | 3.96 | | |
| Ice Cream | | 0.70 | | | |
| Lard | 57.4 | 0.64 | | | |
| Linseed Oil | 57.9 | 0.44 | | 552 | |
| Maple Syrup | | 0.48 | | | |
| Meat, Fresh, Average | 90± | 0.70 | | | |
| Mercury | 845 | 0.033 | 59.64 | 675 | 117 |
| Methyl Acetate | 54.8 | 0.47 | | 133 | 176.5 |
| Methyl Chloroform | 82.7 | 0.26 | | 165 | 95 |
| Methylene Chloride | 82.6 | 0.288 | | 104 | 142 |
| Milk, 3.5% | 64.2 | 0.90 | | | |
| Molasses | 87.4 | 0.60 | | 220± | |
| Nitric Acid, 7% | 64.7 | 0.92 | | 220 | 918 |
| Nitric Acid, 95% | 93.5 | 0.5 | | 187 | 207 |
| Nitrobenzene | | 0.35 | | 412 | 142.2 |
| Olive Oil | 58 | 0.47 | | 570 | |
| Perchloroethylene | 101.3 | 0.21 | | 250 | 90 |
| Petroleum Products: | | | | | |
| Asphalt | 62.3 | 0.42 | 5.04 | | |
| Benzene | 56 | 0.42 | 1.04 | 175 | 170 |
| Fuel Oils: | | | | | |
| Fuel Oil #1 (Kerosene) | 50.5 | 0.47 | 1.008 | **440± | 86 |
| Fuel Oil #2 | 53.9 | 0.44 | 0.96 | | |
| Fuel Oil Medium #3, #4 | 55.7 | 0.425 | 0.918 | **580± | 67 |
| Fuel Oil Heavy #5, #6 | 58.9 | 0.41 | 0.852 | | |
| Gasoline | 41-43 | 0.53 | 0.936 | **280± | 116 |
| Machine/Lube Oils: | | | | | |
| SAE 10-30 | 55.4 | 0.43 | | | |
| SAE 40-50 | 55.4 | 0.43 | | | |
| Napthalene | 54.1 | 0.396 | | 424± | 103 |
| Paraffin, Melted (150°F+) | 56 | 0.69 | 1.68 | 572 | 70 |
| Propane (Compressed) | 0.13 | 0.576 | 1.81 | -48.1 | |
| Toluene | 53.7 | 0.42 | 1.032 | | |
| Transformer Oils | 56.3 | 0.42 | 0.9 | | |
| Phenol (Carbolic Acid) | 66.6 | 0.56 | | 346 | |
| Phosphoric Acid, 10% | 65.4 | 0.93 | | | |
| Phosphoric Acid, 20% | 69.1 | 0.85 | | | |

Reference Data

CONTINUED

* At or near room temperature.

** Average value shown. Boils at various temperatures within the distillation range for the material. Verify exact value from application originator.

To convert to kg/m³ multiply lb/ft³ by 16.02

To convert to kJ/kg multiply Btu/lb by 2.326

To convert to kJ/kg-°C multiply Btu/lb-°F by 4.187

To convert to W/m-°C multiply Btu-in/hr-ft²-°F by 0.1442

Applications Guide

Reference Data

Physical Properties of Solids, Liquids and Gases

Continued

| Substance | *Density lbs./ft ³ | Specific Heat Btu lb.-°F | *Thermal Conductivity Btu-in hr.-ft ² -°F | Boiling Point °F | Heat of Vaporization Btu/lb. |
|--|----------------------------------|--------------------------------|--|---------------------|---------------------------------|
| Polyurethane Foam Components (MDI System): | | | | | |
| Part A Isocyanate | 77 | 0.6 | 1.14 | | |
| Part B Polyol Resin | 74.8 | 0.7 | 1.32 | | |
| Potassium (1000°F) | 44.6 | 0.18 | 260.40 | 1400 | 893 |
| Propionic Acid | 61.8 | 0.56 | | 286 | 177.8 |
| Propyl Alcohol | 50.2 | 0.57 | | 208 | 295.2 |
| Sea Water | 64.2 | 0.94 | | | |
| Sodium (1000°F) | 51.2 | 0.30 | 580 | 1638 | 1810 |
| Sodium Hydroxide (Caustic Soda) | | | | | |
| 30% Sol. | 82.9 | 0.84 | | | |
| 50% Sol. | 95.4 | 0.78 | | | |
| Soybean Oil | 57.4 | 0.24-0.33 | | | |
| Starch | 95.4 | | | | |
| Sucrose, 40% Sugar Syrup | 73.5 | 0.66 | | 214 | |
| Sucrose, 60% Sugar Syrup | 80.4 | 0.74 | | 218 | |
| Sulfur, Melted (500°F) | 112 | 0.24 | | 832 | 120 |
| Sulfuric Acid, 20% | 71 | 0.84 | | 218 | |
| Sulfuric Acid, 60% | 93.5 | 0.52 | 2.88 | 282 | |
| Sulfuric Acid, 98% | 114.7 | 0.35 | 1.8 | 625 | 219 |
| Trichloroethylene | 91.3 | 0.23 | 0.84 | 188 | 103 |
| Trichloro-Trifluoroethane | 94.6 | 0.21 | | 118 | 63 |
| Turpentine | 54 | 0.42 | | 319 | 133 |
| Vegetable Oil | 57.5 | 0.43 | | | |
| Vegetables, Fresh, Average | 50-60 | 0.92 | | | |
| Water | 62.4 | 1.00 | 4.08 | 212 | 965 |
| Wines, Table & Dessert, Average | 64.2 | 0.90 | | | |
| Xylene | 53.8 | 0.411 | | 288 | 149.2 |

* At or near room temperature.

** Average value shown. Boils at various temperatures within the distillation range for the material. Verify exact value from application originator.

To convert to kg/m³ multiply lb/ft³ by 16.02

To convert to kJ/kg multiply Btu/lb by 2.326

To convert to kJ/kg-°C multiply Btu/lb-°F by 4.187

To convert to W/m-°C multiply Btu-in/hr-ft²-°F by 0.1442

Applications Guide

Reference Data

Physical Properties of Solids, Liquids and Gases

Continued

Properties of Gases—Ref. 136

| Substance | *Density lb./ft ³ | *Specific Heat at Constant Pressure Btu/lb. - °F | *Thermal Conductivity Btu-in./hr.-ft ² -°F |
|--------------------------------|---------------------------------|---|--|
| Acetylene | 0.073 | 0.35 | 0.129 |
| Air | 0.076 | 0.240 | 0.18 |
| Alcohol, Ethyl (Vapor) | | 0.4534 | |
| Alcohol, Methyl (Vapor) | | 0.4580 | |
| Ammonia | 0.044 | 0.523 | 0.16 |
| Argon | 0.103 | 0.124 | 0.12 |
| Butane | 0.1623 | | 0.0876 |
| Butylene | 0.148 | | |
| Carbon Dioxide | 0.113 | 0.199 | 0.12 |
| Carbon Monoxide | 0.078 | 0.248 | 0.18 |
| Chlorine | 0.184 | 0.115 | 0.06 |
| Chloroform | | 0.1441 | 0.046 |
| Chloromethane | 0.1309 | 0.24 | 0.0636 |
| Dichlorodifluoromethane (F-12) | 0.329 | 0.143 | 0.058 |
| Ethyl Chloride | 0.1703 | | 0.066 |
| Ethylene | 0.0728 | 0.40 | 0.1212 |
| Ethyl Ether | | 0.4380 | 0.0924 |
| Helium | 0.0104 | 1.25 | 1.10 |
| Hydrochloric Acid | 0.0946 | 0.191 | |
| Hydrogen | 0.0056 | 3.43 | 0.13 |
| Hydrogen Sulfide | 0.096 | 0.2451 | 0.091 |
| Methane | 0.0447 | 0.60 | 0.21 |
| Nitric Oxide | 0.0779 | 0.231 | 0.1656 |
| Nitrogen | 0.075 | 0.249 | 0.19 |
| Nitrous Oxide | 0.1143 | 0.221 | 0.1056 |
| Oxygen | 0.082 | 0.218 | 0.18 |
| Sulfur Dioxide | 0.179 | 0.155 | 0.07 |
| Water Vapor (212°F) | 0.0372 | 0.482 | 0.16 |

Properties of Air*—Ref. 137

| Temperature (°F) | Specific Heat (Btu/lb.-°F) | Density (lb./ft ³) |
|------------------|----------------------------|--------------------------------|
| 0 | 0.240 | 0.086 |
| 50 | 0.240 | 0.078 |
| 100 | 0.240 | 0.071 |
| 150 | 0.241 | 0.065 |
| 200 | 0.242 | 0.060 |
| 250 | 0.243 | 0.056 |
| 300 | 0.244 | 0.052 |
| 350 | 0.245 | 0.049 |
| 400 | 0.247 | 0.046 |
| 450 | 0.248 | 0.043 |
| 500 | 0.249 | 0.041 |
| 550 | 0.250 | 0.039 |

| Temperature (°F) | Specific Heat (Btu/lb.-°F) | Density (lb./ft ³) |
|------------------|----------------------------|--------------------------------|
| 600 | 0.252 | 0.037 |
| 650 | 0.253 | 0.035 |
| 700 | 0.254 | 0.034 |
| 750 | 0.256 | 0.033 |
| 800 | 0.257 | 0.032 |
| 850 | 0.258 | 0.030 |
| 900 | 0.260 | 0.029 |
| 950 | 0.261 | 0.028 |
| 1000 | 0.262 | 0.027 |
| 1050 | 0.264 | 0.026 |
| 1100 | 0.265 | 0.025 |
| 1150 | 0.266 | 0.025 |
| 1200 | 0.267 | 0.024 |

* At 60°F and atmospheric pressure (14.7 psia)
 To convert to kg/m³ multiply lb./ft³ by 16.02
 To convert to kJ/kg multiply Btu/lb by 2.326
 To convert to kJ/kg-°C multiply Btu/lb-°F by 4.187
 To convert to W/m-°C multiply BTU-in/hr-ft²-°F by 0.1442

Application Guide

Reference Data

Corrosion Guide

The Watlow Corrosion Guide represents a compilation of available data and application experience on the relative compatibility of common heater sheath materials and corrodants. This can be valuable in the initial selection of a heater sheath material to be used with a listed corrodant. Final selection, however, should be made based upon the specific exposure conditions, recommendations of the corrosive agent's manufacturer and preliminary testing.

Rating System

- A**—Good
- B**—Fair
- C**—Conditional—Performance is dependent upon specific application conditions such as solution concentration and temperature.
- X**—Unsuitable—Should not be used.

Notes to Corrosion Guide

1. This solution involves a mixture of various chemical compounds whose identity and proportions are unknown or subject to change without our knowledge. Check supplier to confirm choice of sheath material plus alternate sheath materials that may be used.
2. Caution—Flammable material.
3. Chemical composition varies widely. Check supplier for specific recommendations.

4. Direct immersion heaters not practical. Use clamp-on heaters on outside surface of cast iron pot.
5. Element surface loading should not exceed 3 W/cm² (20 W/in²).
6. For concentrations greater than 15 percent, element surface loading should not exceed 3 W/cm² (20 W/in²).
7. See suggested watt density chart.
8. Remove crusts at liquid level.
9. Clean often.
10. Do not exceed 2 W/cm² (12 W/in²).
11. Passivate stainless steel, Inconel[®] and Incoloy[®].

Note: Blank spaces indicate an absence of data to establish a rating.

Ref. 138

| Corrodant | Boiling Point °B.P. °F. | Flash Point °F.P. °F. | Auto Ignition A.I. °F. | Iron Steel | Cast Iron Grey | Cast Iron NI Resist | Aluminum | Copper | Lead | Monel [®] 400 | Nickel 200 | 304, 321, 347 Stainless Steel | 316 Stainless Steel | Type 20 Stainless Steel | Incoloy [®] 800 | Inconel [®] 600 | Titanium | Hastelloy [®] B | Quartz | Graphite | Teflon [®] | Comments | | | |
|----------------------------------|-------------------------------|-----------------------------|------------------------------|------------|----------------|---------------------|----------|--------|------|------------------------|------------|----------------------------------|---------------------|----------------------------|--------------------------|--------------------------|----------|--------------------------|--------|----------|---------------------|----------|--------|---|---|
| Acetaldehyde | 69 | -33 | 365 | | | | B | X | B | B | B | A | A | A | | B | A | C | | A | A | A | Note 2 | | |
| Acetic Acid | 244 | 109 | 800 | X | X | | C | X | X | B | C | C | B | A | C | C | A | | | A | A | A | | | |
| Crude | | | | X | | | C | A/B | B | X | B | B | A/B | A/B | A | C | C | | | | | | A | | |
| Pure | | | | | | | X | A | B | B | A | B | A | A | | C | C | | | | | | A | | |
| Vapors | | | | | | | X | C | B | X | B | B | X | X | A | C | C | A/B | A | | | | | Hastelloy [®] C-276 Acceptable | |
| 150 PSI, 400°F | | | | | | | C | B | X | B | B | | | | | C | C | | | | | | | | |
| Aerated | | | | | X | X | X | C | X | X | X | X | X | B | B | | X | A | | | | | | | |
| No Air | | | | | X | X | C | B | X | A | B | C | B | B | | X | A | | | | | | | | |
| Acetone | 134 | 0 | 1000 | C | X | B | B | A | A/B | A | A | A | A | A | A | A | A | A | A | A | A | A | A | Note 2 | |
| Actane [™] 70 | | | | | | | | | | | | | | | | | | | | | | | A | Note 1 | TM: Enthone, Inc. Acid additive for pickling of metals. |
| Actane [™] 80 | | | | | | | | | | | | | | | | | | | | | | | A | Note 1 | |
| Actane [™] Salt | | | | | | | | | | | | | | | | | | | | | | | A | Note 1 | |
| Alboloy Process | | | | | | | | | | | | | | | | | | | | | | | | | |
| Alcoa [™] R5 Bright Dip | | | | | | | | | | | | | | | | | | | | | | | A | Note 1 | TM: This is a proprietary process licensed to individuals by Alcoa. |
| Allyl Alcohol | 207 | 70 | 713 | | A | A | B | A | B | A | A | A | A | A/B | A | A | A/B | | | | | | A | A | |
| Alcohol | | | | B | B | | B | A | A | A | A | B | A | A | A | A | A | A | A | A | A | A | | Note 2 | |

CONTINUED

Application Guide

Reference Data

| Corrodant | B.P. °F | Flash Point °F | Auto Ignition A.I. °F | Iron Steel | Cast Iron Grey | Cast Iron NI Resist | Aluminum | Copper | Lead | Monel® 400 | Nickel 200 | 304, 321, 347 Stainless Steel | 316 Stainless Steel | Type 20 Stainless Steel | Incoloy® 800 | Inconel® 600 | Titanium | Hastelloy® B | Quartz | Graphite | Teflon® | Comments |
|-----------------------------------|------------|----------------------|--------------------------------|------------|----------------|---------------------|----------|--------|------|------------|------------|----------------------------------|---------------------|----------------------------|--------------|--------------|----------|--------------|--------|----------|---------|--|
| Aalcorite™ | | | | | | | | | | | | | | | | | | A | | | | Note 1 TM: Fredrick Gumm Chemical Co. Aluminum conversion coating. |
| Alkaline Solutions | | | | A | | | | | | | | A | | | | | | | | | | |
| Alkaline Cleaners | | | | | | | | | | | | A | | | | | | | | | X | Note 1 |
| Alkaline Soaking Cleaners | | | | A | | | | | | | | | | | | | | | | | | Note 1 |
| Alodine™ | | | | | | | | | | | | | A | | | | | | | | | Note 1 TM: Amchem Products Inc. Protective coating chemical for aluminum. |
| 200°F | | | | | | | | | | | | A347 | A | | | | | | | | | |
| Aluminum (Molten) | 3732 | | | | | | | | | | | | | | | | | | | | | Contact Factory |
| Aluminum Acetate | | | | X | X | | B | B | A | B | B | A/B | A | A | | B | A | A | | | | A |
| Aluminum Bright Dip | | | | | | | | | | | | | | | | | | | | | A | A |
| Aluminum Chloride | 356 | | | X | X | | X | X | X | X | X | X | X | X | X | X | X | A | A | A | A | Note 1 |
| Aluminum Cleaners | | | | C | C | | X | X | X | A | A | A | A | B | A | A | B | | X | X | | Notes 1, 9 |
| Aluminum Potassium Sulfate (Alum) | | | | | X | X | X | A/B | B | B | B | X | B/C | B | | B | A/B | | | | A | A |
| Aluminum Sulfate | | | | X | X | X | X | X | B | X | X | B | B | B | X | X | A | B | A | A | A | Note 1 |
| Alum | | | | | | | | | | | | | | | | | | | | | | See Aluminum Potassium Sulfate |
| Ammonia | | | | X | X | | C | X | C | X | X | X | X | X | C | B | A | A | A | A | | |
| Ammonia (Anhydrous) (Gas) | -28 | | 1204 | B | | | X | X | | X | | A | A | A | | | | A | | A | A | Hastelloy® C-276 Acceptable |
| Cold | | | | C | | A | A | A | B | A | A | A | A | A | | A | A | | | | | |
| Hot | | | | C | | C | | A | X | A | A | C | C | A | | A | | | | | | |
| Ammonia and Oil | | | | A | | | | | | | | | | | | | | | | | | |
| Ammonium Acetate | | | | A | B | B | A/B | X | X | A | A | A/B | A/B | A/B | A | A | B | B | | A | A | |
| Ammonium Bifluoride | | | | X | X | | X | X | X | X | X | X | X | B | X | X | X | A | X | A | A | |
| Ammonium Chloride | 640 | | | X | X | B | X | X | X | B | B | X | C | C | C | C | A | A | A | A | A | Hastelloy® C-276 Acceptable |
| Ammonium Hydroxide | | | | B | B | B | C | X | B | X | A | A | A/B | A | A | A | A | X | A | A | A | |
| Ammonium Nitrate | | | | B/X | X | C | B | X | X | X | X | A | A | A | X | X | X | | A | A | A | |
| Ammonium Persulfate | | | | X | X | | B/X | X | C | X | X | B/X | B | B | | X | B | X | A | A | A | |
| Ammonium Sulfate | | | | X | X | B | X | X | B | B | B | C | B | B | B | B | A | B | A | A | | |
| Amyl Acetate | 298 | 77 | 714 | B | | | A | A/B | | A | A | A | A | A | A | A | A | | A | A | A | Hastelloy® C-276 Acceptable |
| Amyl Alcohol | 280 | 91 | 572 | A | B | B | C | A/B | | A | B | A304 | A/B | A/B | A | A | A/B | | A | A | A | |
| Aniline | 364 | 158 | 1418 | B | A | | B | X | B | B | B | | A | A | B | B | A | B | A | A | A | |
| Aniline, Oil | | | | A | | | X | X | | | | A | A | | | | | | | | | |

Reference Data

CONTINUED 

Application Guide

Reference Data

| Corrodant | Boiling Point | Flash Point | Auto Ignition | Iron Steel | Cast Iron Grey | Cast Iron NI Resist | Aluminum | Copper | Lead | Monel® 400 | Nickel 200 | 304, 321, 347 Stainless Steel | 316 Stainless Steel | Type 20 Stainless Steel | Incoloy® 800 | Inconel® 600 | Titanium | Hastelloy® B | Quartz | Graphite | Teflon® | Comments |
|---|---------------|-------------|---------------|------------|----------------|---------------------|----------|--------|------|------------|------------|-------------------------------|---------------------|-------------------------|--------------|--------------|----------|--------------|--------|----------|---------|---|
| | B.P. °F | F.P. °F | A.I. °F | | | | | | | | | | | | | | | | | | | |
| Aniline, Dyes | | | | | | | | | | A | | A | A | | | | | | | | | |
| Anodizing | | | | X | X | | X | X | A | X | X | X | X | A | X | X | X | | A | A | A | |
| Anodizing Solutions (10% Solution) | | | | | | | | | | | | | | | | | | | | | | |
| Chromic Acid 96°F | | | | C | | | | | | | | A | A | | | | A | | | | | |
| Sulfuric Acid 70°F | 626 | | | | | | | A | | | | | | A | | | | | | | | |
| Sodium Hydroxide 160°F | 2534 | | | A | | | A | | | A | | A | A | A | A | A | | | | | | |
| Nigrosine 150°F | | | | | | | | | | | | | | | | | | | | | | |
| Black Dye | | | | | | | | | | A | B | | | | | | | | | | | |
| Nickel Acetate 200°F | | | | | | | | | C | A | B | | | | | | | | | | | |
| Arp™ 28 | | | | | | | | | | | | | | | | | | | | A | A | Note 1 TM: Specialty Chemicals, Allied-Kelite Products Div., The Richardson Co. |
| Arp™ 80 Blackening Salt | | | | | | | | | | | | | | | | | | | | A | | Note 1 |
| Arsenic Acid | | | | X | X | | X | X | X | X | X | C | B | B | X | X | X | | A | A | A | |
| Asphalt | <878 | 400 + | 905 | A | A | | X | X | X | X | A/B | A/B | A | A | A | A | A | | A | A | A | |
| Barium Chloride | 2840 | | | | | | X | | | | A | B | B | | A | B | B | | A | A | | |
| Barium Hydroxide | | | | B | B | | X | X | X | B | A | B | A | A/B | B | B | X | B | A | A | A | |
| Barium Sulfate | | | | B | B | B | B | B | B | B | B | B | B | B | B | B | A | B | A | A | A | |
| Barium Sulfide (Barium Monosulfide) | | | | B | | | X | X | A/X | A | | A/B | B | B | | | | | | A | A | |
| Barium Sulfite | | | | | | | | | | | | B | | | | | | | | | | |
| Black Nickel | | | | | | | | | | | | | | | | | | | | A | A | Note 5 |
| Black Oxide | | | | | | | | | | | | A | | | | | | | | | | Note 5 |
| Bleaching Solution (1 ½ lb. Oxalic Acid per gallon H ₂ O at 212°F) | | | | | | | | | A | | | F | | | | | | | | | | |
| Bonderizing™ (Zinc Phosphate) | | | | C | | B | | | | | | A | A | | | | | | | | | |
| Boric Acid | | | | X | X | | X | C | C | C | C | C | C | C | C | C | A | A | A | A | A | A |
| Brass Cyanide | | | | | | | | | | | | A | | | | | | | | | | Note 1 |
| Bright Copper–Acid See Copper Bright Acid | | | | | | | | | | | | | | | | | | | | | | |
| Bright Copper–Cyanide See Copper Cyanide | | | | | | | | | | | | | | | | | | | | | | |
| Bright Nickel | | | | | | | | | | | | | | | | | A | A | | | | Notes 1, 5 |
| Brine (Salt Water) | | | | | | | | | | A | | | | | | B | | | | A | A | |
| Bronze Plating | | | | A | | | | | | | | A | | | | | | | | | | Note 1 |
| Butanol (Butyl Alcohol) | 243 | 84 | 689 | A/B | A | | B | A/B | A | A | A | A | A | A | A | A | A/B | B | A | A | A | Note 1 |
| Cadmium Black | | | | | | | | | | | | | | | | | | | | A | | Note 1 |
| Cadmium Fluoborate | | | | | | | | | | | | | | | | | | | | A | A | Note 1 |
| Cadmium Plating | | | | | | | | | | | | A | | | A | A | | | | | | Note 1 |
| Calcium Chlorate | | | | B | B | | B | C | C | B | B | B | B | B | B | B | | | | A | | |

CONTINUED

Application Guide

Reference Data

| Corrodant | Boiling Point | Flash Point | Auto Ignition | Iron Steel | Cast Iron Grey | Cast Iron NI Resist | Aluminum | Copper | Lead | Monel® 400 | Nickel 200 | 304, 321, 347 Stainless Steel | 316 Stainless Steel | Type 20 Stainless Steel | Incoloy® 800 | Inconel® 600 | Titanium | Hastelloy® B | Quartz | Graphite | Teflon® | Comments |
|---|---------------|--------------------------|---------------|------------|----------------|---------------------|----------|--------|------|------------|------------|-------------------------------|---------------------|-------------------------|--------------|--------------|----------|--------------|--------|----------|---------|-----------------------------|
| | B.P. °F | F.P. °F | A.I. °F | | | | | | | | | | | | | | | | | | | |
| Calcium Chloride | > 2912 | | | B | B | | C | B | X | B | B | B | B | B | B | B | A | A | A | A | A | Hastelloy® C276 Acceptable |
| Carbolic Acid (Phenol) | 362 | 175 | 1319 | B | B | B | B | X | B | B | B | C | X | B | B | B | A | A | A | A | A | Hastelloy® C276 Acceptable |
| Carbon Dioxide–Dry Gas | | | | X | X | A | A | A | B | A | A | A/B | A/B | A | A | A | X | A | A | X | X | Hastelloy® C-276 Acceptable |
| Carbon Dioxide–Wet Gas | | | | X | X | C | A | X | B | A | A | A/B | A/B | A/B | A | A | X | A | A | X | X | |
| Carbon Tetrachloride | | | | X | X | C | X | C | A | A | A | C | B | B | A | A | A | A | A | A | A | Hastelloy® C-276 Acceptable |
| Carbonic Acid | 359 | 175 | 1319 | C | C | | C | C | X | C | C | A/B | B | A | B | A | A | | A | A | A | |
| Castor Oil | 595 | 445 | 840 | A | A | | A/B | A | A | A | A | A/B | A/B | A | A | A | A | | A | A | A | |
| Caustic Etch | | | | A | A | | X | X | | A | A | A | A | X | X | X | A | | A | A | X | |
| Caustic Soda (Lye) (Sodium Hydroxide) | | | | | X | X | A | X | X | X | C | C | X | C | C | C | B | C | | X | A | Notes 6, 8 |
| 2% | | | | | B | B | B | X | B | X | A | A | X | B | A | A | A | A | | | | |
| 10–30%, 210°F | | | | | B | B | A | X | B | X | A | A | A | A | A | A | A | A | | | | |
| 76%, 180°F | | | | | X | X | X | X | X | X | B | A | B | B | B | A | A | B | | | | |
| Chlorine Gas: | | | | | | | | | | | | | | | | | | | | | | |
| Dry | -30 | | | X | X | B | X | X | X | B | C | C/X | C | B | C | B | B/X | B | A | B | B | Note 2 |
| Wet | -30 | | | X | X | X | X | X | X | X | X | X | X | X | X | X | X | | A | X | A/X | Note 2 |
| Chloroacetic Acid (Monochloroacetic Acid) | 372 | None | | X | X | | X | X | X | B | B | X | X | | C | C | A | A | A | A | A | Hastelloy® C-276 Acceptable |
| Chromic Acetate | | | | | | | | | | | | | | | | | | | A | | | Note 1 |
| Chromic Acid | | | | X | C | X | X | X | B | X | X | X | X | X | X | X | A | | A | A | X | |
| Chromium Plating | | | | X | X | | X | X | B | X | X | X | X | X | X | X | A | | A | A | X | |
| Chromylite | | | | | | | | | | | | | | | | | | | A | | | Note 1 |
| Citric Acid | | | | X | X | C | C | C | X | B | B | C | C | B | B | B | A | A | A | A | A | Hastelloy® C276 Acceptable |
| Clear Chromate | | | | | | | | | | | | | A | | | | | | | | | Note 1 |
| Cobalt Acetate at 130°F | | | | | | | | | | B | B | A | A | | B | B | | | | | | |
| Cobalt Nickel | | | | | | | | | | | | | | | | | | | | A | | Notes 1, 6 |
| Cobalt Plating | | | | | | | | | | | | A | | | | | | | | A | | Note 1 |
| Coconut Oil | | 420 Crude 548 Refined | | | | | | | B | A | | | | | | | | | | | | |
| Cod Liver Oil | | 412 | | | | | A | | | | A | A | A | A | A | A | | | | | | |
| Copper Acid | | | | | | | | | | | | | | | | | | | A | A | | Note 1 |
| Copper Bright | | | | | | | | | | | | A | A | | | | | | | | | Note 1 |
| Copper Bright Acid | | | | | | | | | | | | | | | | | | | | A | | |
| Copper Chloride | | | | X | X | | C/X | X | C | X | X | X | X | X | X | X | A | B | A | A | A | |
| Copper Cyanide | | | | A | A | | X | X | | C | X | B | B | B | X | X | | B | A | A | A | |
| Copper Fluoborate | | | | | | | | | | B | B | B | B | B | B | B | | | | | A | A |
| Copper Nitrate | | | | X | X | X | X | X | | X | X | A/B | A/B | A/B | X | X | | X | A | A | A | |
| Copper Plating | | | | A | | | | | | | | | | | | | | | | | | |
| Copper Pyrophosphate | | | | | | | | | | | | A | | | | | | | | | | Note 1 |
| Copper Strike | | | | A | A | | | | | | | A | | | | | | | | | | Note 1 |
| Copper Sulfate | | | | X | X | B | X | C/X | A | X | X | B | B | A/B | C | X | A | B | A | A | A | Hastelloy® C276 Acceptable |

Reference Data

CONTINUED

Application Guide

Reference Data

| Corrodant | Boiling Point | Flash Point | Auto Ignition | Iron Steel | Cast Iron Grey | Cast Iron NI Resist | Aluminum | Copper | Lead | Monel® 400 | Nickel 200 | 304, 321, 347 Stainless Steel | 316 Stainless Steel | Type 20 Stainless Steel | Incoloy® 800 | Inconel® 600 | Titanium | Hastelloy® B | Quartz | Graphite | Teflon® | Comments | |
|---------------------------|---------------|-------------|---------------|------------|----------------|---------------------|----------|--------|------|------------|------------|-------------------------------|---------------------|-------------------------|--------------|--------------|----------|--------------|--------|----------|---------|--|--------|
| | B.P. °F | F.P. °F | A.I. °F | | | | | | | | | | | | | | | | | | | | |
| Creosote | 392 -482 | 165 | 637 | A | B | B | C | B | X | B | B | B | B | B | B | B | | | | A | A | Note 2 | |
| Cresylic Acid (Cresol) | 376 -397 | 110 | | C | C | | C | C | X | B | B | B | A | A | C | B | B | B | A | A | A | Note 2 | |
| Deionized Water | | | | X | X | | X | X | | A | A | A | A | A | A | A | | | | | | Note 11 | |
| Deoxidine™ | | | | | | | | | | | | A | | | | | | | | | | TM: Amchem Products, Inc. Metal cleaner, rust remover | |
| Deoxylite™ | | | | | | | | | | | | A | | | | | | | | | | TM: Amchem Products, Inc. | |
| Deoxidizer (Etching) | | | | | | | | | | | | | | | | | | | | A | | Note 1 | |
| Deoxidizer (3AL-13) | | | | | | | | | | | | A | A | | | | | | | | | Note 1 Non-Chrome | |
| Dichromic Seal | | | | X | X | | | | | | | | | | | | | | | | | | |
| Diethylene Glycol | 474 | 255 | 444 | B | A | | B | B | A | B | B | A | A | A | B | B | A | | A | A | A | | |
| Diphenyl 300°F–350°F | 491 | 235 | 1004 | A | A | A | A | A | A | A | A | A | | A | | A | B | B | | | | | |
| Disodium Phosphate | | | | A | | | | | | | | | | B | | | | | | | A | | |
| Diversey™–DS9333 | | | | | | | | | | | | | | | | | | | | A | | Note 1 TM: Diversey Chemical Co. | |
| Diversey™ 99 | | | | A | | | | | | | | | | | | | | | | | | | |
| Diversey™ 511 | | | | | | | | | | | | | | | | | | | | A | | Notes 1, 5 | |
| Diversey™ 514 | | | | | | | | | | | | | | | | | | | | A | A | Note 1 | |
| Dowtherm™ A | | | | A | | | | | | | | | | | | | | | | | | TM: Dow Chemical Co. Heat transfer agent | |
| Dur-Nu™ | | | | | | | | | | | | | | | | | | A | A | | | Note 1, 5 TM: The Duriron Co., Inc. | |
| Electro Cleaner | | | | A | | | | | | | | A | | | | | | | | | | Note 1 | |
| Electro Polishing | | | | | | | | | | | | | | | | | | | | A | | Note 1 | |
| Electroless Nickel | | | | | | | | | | | | | | | | | | A | A | | | Note 1 | |
| Electroless Tin | | | | | | | | | | | | | | | | | | | | | | | |
| (Acid) | | | | | | | | | | | | | | | | | | | | A | | Note 1 | |
| (Alkaline) | | | | | | | | | | | | | A | | | | | A | | | | Note 1 | |
| Enthone Acid–80 | — | | | | | | | | | | | | | | | | | | | | A | A | Note 1 |
| Ether | 94 | -49 | 356 | B | B | | B | B | B | B | B | B | B | A | B | B | A | | A | | | Note 2 Carpenter 20 Acceptable | |
| Ethyl Chloride (No Water) | 54 | -58 | 966 | B | B | | B | A | B | B | A | B | B | A | B | A | A | B | A | A | A | Note 2 | |
| Ethylene Glycol | 387 | 232 | 775 | A | B | | A | B | X | B | B | B | B | B | B | B | A | A | A | A | A | Note 5 Hastelloy® C-276 Acceptable | |
| Fatty Acids | | | | X | X | | A | C/X | X | B | B | C/B | A | A | B | B | A | A | A | A | A | Carpenter 20 Accep., Hastelloy® C-276 Accep. | |
| Ferric Chloride | 606 | | | X | X | X | X | X | X | X | X | X | X | X | X | X | A | C | A | A | A | | |
| Ferric Nitrate | | | | X | X | | X | X | | X | X | B | B | A | X | X | | X | A | A | A | Carpenter 20 Acceptable | |
| Ferric Sulfate | | | | X | X | X | X | X | A/B | X | C | B | B | B | C | C | A | X | A | A | A | | |
| Fluoborate | | | | | | | | | | | | | | | | | | | | A | A | Note 1 | |
| Fluoborate (High Speed) | | | | | | | | | | | | | | | | | | | | A | | Note 1 | |
| Fluorine Gas, Dry | -305 | | | C | X | | C/X | X | X | A | A | C | A/C | A/C | C | A | A | B | C | X | X | | |
| Formaldehyde | 27 | 122 185 | 806 | X | X | B | B | B | X | B | B | A | A | A | B | B | A | | A | A | A | | |
| Formic Acid | 213 | 156 | 1114 | X | X | | X | B | X | C | C | X | C | A | B | C | X | A | A | A | A | Carpenter 20 Accep., Hastelloy® C-276 Accep. | |
| Freon | | | | A | A | A | A | A | A | A | A | A | A | A | A | A | | | | | | | |
| Fuel Oil–Normal | | | | A | A | | A/B | A | A | B | B | A/B | A/B | A | B | B | A | B | | A | A | Notes 2, 3, 7 | |

CONTINUED 

Application Guide

Reference Data

| Corrodant | Boiling Point | Flash Point | Auto Ignition | Iron Steel | Cast Iron Grey | Cast Iron NI Resist | Aluminum | Copper | Lead | Monel® 400 | Nickel 200 | 304, 321, 347 Stainless Steel | 316 Stainless Steel | Type 20 Stainless Steel | Incoloy® 800 | Inconel® 600 | Titanium | Hastelloy® B | Quartz | Graphite | Teflon® | Comments |
|---|---------------|-------------|---------------|------------|----------------|---------------------|----------|--------|------|------------|------------|-------------------------------|---------------------|-------------------------|--------------|--------------|----------|--------------|--------|----------|---------|---|
| | B.P. °F | F.P. °F | A.I. °F | | | | | | | | | | | | | | | | | | | |
| Fuel Oil–Acid | | | | X | X | X | X | A | C | C | C | C | B | A | C | C | A | | | | | Notes 2, 3, 7 Carpenter 20 Acceptable |
| Gasoline–Refined | 280± | -45 | 495 | A | A | A | A/B | A/B | A | B | B | A | A | A | B | B | | B | A | A | A | Notes 2, 5 |
| Gasoline–Sour | | | | C | C | | C | C | A | X | X | B | B | A | X | X | | B | A | A | A | Notes 2, 3, 5 Carpenter 20 Acceptable |
| Glycerine (Glycerol) | 554 | 320 | 739 | B | C | B | A | B | B | A | A | A | A | A | A | A | A | A | A | A | A | Hastelloy® C-276 Acceptable |
| Gold–Acid | | | | A | | | | | | | | | | | | | A | A | | | | Note 1 |
| Gold–Cyanide | | | | | | | | | | | | A | A | | | | | | | | | Note 1 |
| Grey Nickel | | | | | | | | | | | | | | | | | A | A | | | | Notes 1, 5 |
| Holdene 310A Tempering Bath | | | | | | | | | | | A | | | | | | | | | | | |
| Hot Seal Sodium Dichromate | | | | | | | | | | | | | A | | | | | | | | | Note 1 |
| Houghtone Mar Tempering Salt | | | | C | | | | | | | C | | | | | | | | | | | |
| Hydrocarbons–Aliphatic | | | | A | A | | A | A | | A | A | A | A | A | A | A | | | A | A | | Note 2 |
| Hydrocarbons–Aromatic | | | | A | A | | A | A | | A | A | A | A | A | A | A | | | A | A | | Note 2 |
| Hydrochloric Acid (No Air) | -120 | | | | | | | | | | | | | | | | | | | | | |
| <150°F | | | | X | X | X | X | X | X | X | X | X | X | X | X | X | X | X | | A | A | |
| >150°F | | | | X | X | | X | X | X | X | X | X | X | X | X | X | X | X | | A | A | A |
| Hydrocyanic Acid (No Air) | 78 | 0 | 100 | X | X | | B | X | X | B | B | B | B | B | B | B | | | | | | |
| Hydrofluoric Acid | 67 | | | | | | | | | | | | | | | | | | | | | |
| Cold <65% | | | | X | X | X | X | X | X | C | X | X | X | C/X | X | X | X | C | X | A | A | Note 5 |
| >65% | | | | B | X | X | X | X | X | C | X | X | X | C | X | X | X | B | | X | A | |
| Hot <65% | | | | X | | | X | X | X | C | X | X | | | | | | | | | | |
| >65% | | | | X | | | X | X | X | C | X | X | X | X | X | X | X | C | | X | A | |
| Hydrogen Peroxide | | | | X | X | X | A | X | X | C | B | B | B | B | B | B | A | C | A | X | A | |
| Indium | 3632 | | | | | | | | | | | | | | | | | | A | A | | Note 1 |
| Iridite™ #4-75, #4-73, #14, #14-2, #14-9, #18-P | | | | | | | | | | | | | A | | | | | | | | | Note 1 TM: Allied-Kelite Products Div., Chromate treatment for ferrous and non-ferrous metals. |
| Iridite™ #1, #2, #3, #4-C, #4PC & S, #4P-4, #4-80, #4L-1, #4-2, #4-2A, #4-2P, #5P-1, #7-P, #8, #8-P, #8-2, #12-P, #15, #17P, #18P | | | | | | | | | | | | | | | | | | | | A | | |
| Iridite™ Dyes–#12L-2, #40, #80 | | | | | | | | | | | | | | | | | | | | A | A | Note 1 |
| Irilac™ | | | | | | | | | | | | | | | | | | | | A | A | Note 1 TM: Allied-Kelite Products Div., Protective coating, clear finish for all metals. |

Reference Data

CONTINUED

Application Guide

Reference Data

| Corrodant | Boiling Point | Flash Point | Auto Ignition | Iron Steel | Cast Iron Grey | Cast Iron NI Resist | Aluminum | Copper | Lead | Monel® 400 | Nickel 200 | 304, 321, 347 Stainless Steel | 316 Stainless Steel | Type 20 Stainless Steel | Incoloy® 800 | Inconel® 600 | Titanium | Hastelloy® B | Quartz | Graphite | Teflon® | Comments | |
|-------------------------------------|---------------|-----------------------------|---------------|------------|----------------|---------------------|----------|--------|------|------------|------------|-------------------------------|---------------------|-------------------------|--------------|--------------|----------|--------------|--------|----------|---------|----------|--|
| | B.P. °F | F.P. °F | A.I. °F | | | | | | | | | | | | | | | | | | | | |
| Iron Fluoborate | | | | | | | | | | | | | | | | | | | | | A | A | Note 1 |
| Iron Phosphate (Parkerizing) | | | | C | | B | | | | | | A | A | | | | | | | | | | |
| Isoprep™ Deoxidizer #187, #188 | | | | | | | | | | | | | A | | | | | | | | | | Note 1 TM: Allied-Kelite Products Div., Cleaners and surface preparation materials. |
| Isoprep™ Acid Aluminum Cleaner #186 | | | | | | | | | | | | | A | | | | | | | | | | Note 1 |
| Isoprep™ #191 Acid Salts | | | | | | | | | | | | | | | | | | | | | A | A | Note 1 |
| Isopropanol (Isopropyl Alcohol) | 180 | 53 | 750 | C | | | B | A | | A | A | A | A/B | A | | A | | | B | | A | A | |
| Jetal™ | | | | | | | | | | | | A | | | | | | | | | | | Note 1 TM: Technic Inc. Blackening Salt |
| Kerosene | 347 617 | 100 165 | 444 | A | | | A | A | A | A | A | A | A | A | A | A | B | B | | | A | A | Note 2 |
| Kolene™ | | | | | | | | | | | A | | | | | | | | | | | | TM: Metal Processing Co., Kolene process-metal cleaning |
| Lacquer Solvent | | | | B | A | A | A | B | A | B | B | A | A | A | B | B | A | | | A | | | Note 2 |
| Lead Acetate | | | | X | X | | X | X | X | A | A | A/B | A/B | A/B | A | A | A | A | B | A | A | A | |
| Lead Acid Salts | | | | | | | | | | | | A | | | | | | | | | | | Note 1 |
| Lime Saturated Water | | | | B | B | | X | B | X | B | B | B | A | B | B | B | | | | X | A | | |
| Linseed Oil | 649 | 432 Raw 403 Boiled | 650 | X | A | | B | B | X | B | B | A | A | A | B | B | B | B | B | A | X | A | Note 2 |
| Magnesium Chloride | 2574 | | | X | C | B | X | B | X | B | A | B | B | A/B | B | A | A | A | A | A | A | A | Carpenter 20 Accep. Hastelloy® C-276 Accep. |
| Magnesium Hydroxide | | | | A | A | A | B | A | A | B | A | A | A | A | A | A | A | A | A | A | A | A | Hastelloy® C-276 Acceptable |
| Magnesium Nitrate | | | | B | B | | B | B | C | B | B | B | B | B | B | X | B | B | A | A | A | A | |
| Magnesium Sulfate | | | | B | B | B | B | B | A | A | A | B | B | A/B | B | A | A/B | | | | A | A | |
| MacDermid™ M629 | | | | | | | | | | | | | | | | | | | | | A | A | Note 1 TM: MacDermid, Inc., Acid Salt-Contains Fluoride |
| Mercuric Chloride | 579 | | | X | X | X | X | X | X | X | X | X | B/X | X | X | X | B | X | X | A | A | A | |
| Mercury | 674 | | | A | A | A | X | X | X | B | B | B | A | A | A | B | X | B | A | A | A | A | Hastelloy® C-276 Acceptable |
| Methyl Alcohol (Methanol) | 149 | 52 | 867 | B | B | | C | B | B | A | A | B | A/B | A/B | B | A | A | A | A | A | A | A | Note 2 Hastelloy® C-276 Acceptable |
| Methyl Bromide | 38 | None | 998 | C | C | | X | B | B | B | B | A | A | A | B | B | A | | | A | A | A | |
| Methyl Chloride | -11 | <32 | 1170 | C | C | | X | A | C | C | C | C | C | C | C | C | A | B | A | A | A | A | Carpenter 20 Acceptable |
| Methylene Chloride | 104 | | 1224 | X | C | | C | C | B | C | B | C | B | A | C | B | A | C | A | A | A | A | Carpenter 20 Acceptable |
| Mineral Oil | | 500 | | A | A | | A/B | A | A | A | A | A | A/B | A | A | A | A | A | A | A | A | A | |
| Muriato | | | | | | | | | | | | | | | | | | | | | A | A | Note 1 |
| Naptha | 300 421 | 100 | 900 950 | A | B | B | A | A | A | A | A | A | A | A | A | A | A | B | A | A | A | A | |
| Napthalene | 424 | 176 | 979 | A | A | A | B | B | A | B | B | A | A | A | B | B | A | B | | | A | A | |
| Nickel Acetate Seal | | | | | | | | | | | | | A | | | | | | | | | | Note 1 |

CONTINUED

Application Guide

Reference Data

| Corrodant | Boiling Point | Flash Point | Auto Ignition | Iron Steel | Cast Iron Grey | Cast Iron NI Resist | Aluminum | Copper | Lead | Monel® 400 | Nickel 200 | 304, 321, 347 Stainless Steel | 316 Stainless Steel | Type 20 Stainless Steel | Incoloy® 800 | Inconel® 600 | Titanium | Hastelloy® B | Quartz | Graphite | Teflon® | Comments |
|-------------------------------------|---------------|-------------|---------------|------------|----------------|---------------------|----------|--------|------|------------|------------|-------------------------------|---------------------|-------------------------|--------------|--------------|----------|--------------|--------|----------|---------|---|
| | B.P. °F | F.P. °F | A.I. °F | | | | | | | | | | | | | | | | | | | |
| Nickel Chloride | 1808 | | | X | X | X | X | X | C | C | X | X | C | C | C | B | B | C | A | A | A | Notes 1, 5 |
| Nickel Plate–Bright | | | | | | | | | A | | | | | | | | A | | A | A | A | Notes 1, 5 |
| Nickel Plate–Dull | | | | | | | | | A | | | | | | | | | | A | A | A | Notes 1, 5 |
| Nickel Plate–Watts Solution | | | | | | | | | | | | | | | | | A | | A | A | A | Notes 1, 5 |
| Nickel Sulfate | | | | X | X | X | X | B | B | C | B | B | B | B | C | B | C | X | A | A | A | |
| Nickel Copper Strike (Cyanide Free) | | | | | | | | | | | | A | A | | | | | | | | | Note 1 |
| Nitric Acid | 187 | | | X | X | X | X | X | X | X | X | C | C | B | X | X | B | X | A | X | A | |
| Nitric Hydrochloric Acid | | | | X | X | | X | X | X | X | X | X | X | X | X | X | X | | A | A | A | |
| Nitric 6% Phosphoric Acid | | | | | | | | | | | | | C | | | | | | A | A | A | Note 1 |
| Nitric Sodium Chromate | | | | | | | | | | | | | A | | | | | | A | A | A | Note 1 |
| Nitrobenzene | 412 | 190 | 900 | A | A | A | A | B | X | A | A | A | A | A | A | A | A | X | A | A | A | Note 2 |
| Oakite™ #67 | | | | | | | | | | | | A | | | | | | | | | | Note 1 TM: Oakite Products Inc., Compounds for cleaning surface heating. |
| Oakite™ #20, 23, 24, 30, 51, 90 | | | | A | | | | | | | | | | | | | | | | | | |
| Oleic Acid | 680 | 372 | 685 | C | C | C | C | C | X | B | B | C | B | A | B | A | B | B | A | A | A | Carpenter 20 Acceptable |
| Oxalic Acid | | | | X | X | X | B | B | X | C | B | X | X | B | X | B | X | B | A | A | A | Cupro Nickel Acceptable |
| Paint Stripper (High Alkaline Type) | | | | A | | | | | | | | | | | | | | | | | | Note 1 |
| Paint Stripper (Solvent Type) | | | | | | | | | | | | | A | | | | | | | | | Notes 1, 2 |
| Paraffin | | | | A | A | | A | A | | B | | A | A | A | | | | B | | A | A | Notes 2, 7 |
| Parkerizing™ (See Iron Phosphate) | | | | | | | | | | | | | | | | | | | | | | TM: Parker Div., OMI Corp., Corrosion Res. Coating |
| Perchloroethylene | 250 | None | | B | B | | C | B | B | A | A | B | B | B | B | A | A | B | A | A | A | |
| Perm-A-Chlor™ | | | | | | | | | | | | A | | | | | | | | | | TM: Detrex Chemical Industries Inc., Degreasing solvent and cleaning compound. |
| Petroleum–Crude < 500°F | | | | B | B | A | A | C | C | A | C | A | A | A | | | | | A | A | | Notes 2, 3, 7 |
| > 500°F | | | | A | | A | A | X | X | X | X | A | | | | | | | | | | |
| >1000°F | | | | X | | | X | X | X | X | X | A | | | | | | | | | | |
| Phenol (See Carboic Acid) | | | | | | | | | | | | | | | | | | | | | | |
| Phosphate | | | | | | | | | | | | | A | | | | | | | | X | Notes 1, 5, 9 |
| Phosphate Cleaner | | | | | | | | | | | | A | | | | | | | | | X | Notes 1, 5, 9 |
| Phosphatizing | | | | | | | | | | | | | A | | | | | | | | X | Notes 1, 5, 9 |
| Phosphoric Acid | | | | | | | | | | | | | | | | | | | | | | |
| Crude | | | | C | | | X | X | C | X | X | C | | | | | | | | | | |
| Pure <45% | | | | X | X | X | C | C | C | B | C | C | C | B | A | A | X | C | | A | A | |
| >45% Cold | | | | X | X | X | X | B | C | B | C | A | B | B | A | | X | A | | A | A | |
| >45% Hot | | | | X | X | X | X | C | X | C | X | X | X | B | A | B | X | C | | A | A | Tantalum Acceptable |

Reference Data

CONTINUED

Application Guide

Reference Data

| Corrodant | Boiling Point | Flash Point | Auto Ignition | Iron Steel | Cast Iron Grey | Cast Iron NI Resist | Aluminum | Copper | Lead | Monel® 400 | Nickel 200 | 304, 321, 347 Stainless Steel | 316 Stainless Steel | Type 20 Stainless Steel | Incoloy® 800 | Inconel® 600 | Titanium | Hastelloy® B | Quartz | Graphite | Teflon® | Comments | |
|--|-----------------------|-------------|---------------|------------|----------------|---------------------|----------|--------|------|------------|------------|-------------------------------|---------------------|-------------------------|--------------|--------------|----------|--------------|--------|----------|---------|---|----------------------------|
| | B.P. °F | F.P. °F | A.I. °F | | | | | | | | | | | | | | | | | | | | |
| Photo Fixing Bath | | | | | | | | | | C | | A | | | | | | | | | | | |
| Picric Acid | >572 Ex- plodes | 302 | 572 | X | X | | X | X | X | X | X | B | B | B | C | C | | | | A | A | A | |
| Potassium Acid Sulfate | | | | | | | | | | | | | | | | | | | | A | A | Note 1 | |
| Potassium Bichromate (Potassium Dichromate) | | | | C | B | B | B | | B | B | B | A | A | A | B | | B | A | A | A | A | | |
| Potassium Chloride | | | | C | X | B | X | C | C | B | B | C | B | A | C | B | A | C | A | A | A | Carpenter 20 Acceptable | |
| Potassium Cyanide | | | | C | X | B | X | X | X | C | B | B | B | B | B | B | X | B | A | C | A | | |
| Potassium Hydrochloric | | | | | | | | | | | | | | | | | | | | A | A | Note 1 | |
| Potassium Hydroxide | 2408 | | | X | X | | X | C | X | B | A | C | C | C | C | B | X | B | X | A | A | | |
| Potassium Nitrate (Salt Peter) | | | | B | B | B | A | B | B | B | B | B | B | B | B | B | A | X | A | A | A | | |
| Potassium Sulfate | | | | C | C | C | A | B | A | A | B | A | A | A | B | B | A | C | A | A | A | | |
| Prestone™ 350°F | | | | A | | | | | | A | | | | | | | | | | | | TM: Union Carbide Corp., Anti-freeze/coolant | |
| R5 Bright Dip for Copper Polish at 180°F | | | | | | | | | | | | | | | | | | | | | | | |
| Reynolds Brightener | | | | | | | | | | | | | | | | | | | | A | A | Note 1 | |
| Rhodium Hydroxide | | | | | | | | | | | | | | | | | | | | A | A | | |
| Rochelle Salt Cyanide | | | | A | | | | | | | | A | | | | | | | | | | Note 1 | |
| Ruthenium Plating | | | | | | | | | | | | | | | | | | | | A | A | Note 1 | |
| Sea Water | | | | X | X | A | X | X | A | A | | C | C | A | B | B | A | C | A | A | A | | |
| Silver Bromide | | | | X | X | | X | X | | C | C | X | X | C | | | A | | A | A | A | | |
| Silver Cyanide | | | | C | C | | X | X | | B | | A | A | A | A | | A | A | A | A | A | | |
| Silver Lume | | | | | | | | | | | | A | | | | | | | | | | Note 1 | |
| Silver Nitrate | 831 | | | X | X | | X | X | X | X | X | C | C | B | C | C | A | C | A | A | A | Hastelloy® C276 Acceptable | |
| Soap Solutions | | | | A | A | A | X | C | A | A | | A/B | A/B | A/B | | A | A | | | X | X | Note 3 | |
| Sodium-Liquid Metal | | | | C | X | X | X | X | B | A | A | A | | | A | A | | | | X | X | | |
| Sodium Bisulfate | | | | X | X | X | C | B | C | C | B | X | X | A | | B | C | B | | A | A | Carpenter 20 Acceptable | |
| Sodium Bromide | 2534 | | | B | C | | X | B | B | B | B | C | B | B | B | B | B | C | A | A | A | | |
| Sodium Carbonate | | | | C | C | | X | A | X | B | B | B | B | A | B | B | A | B | C | A | A | | |
| Sodium Chlorate | | | | X | X | | B | A | B | A | A | B | B | B | B | A | A | X | A | A | A | Cupro-Nickel Acceptable | |
| Sodium Chloride | 2575 | | | C | X | B | X | B | B | A | B | X | X | C | B | A | C | C | A | A | A | Cupro-Nickel Acceptable | |
| Sodium Citrate | | | | X | X | | X | X | X | | C | B | B | B | | | A | B | A | A | A | | |
| Sodium Cyanide | 2725 | | | A | B | C | X | X | X | C | C | A | A | A | A | A | C | B | A | C | A | | |
| Sodium Dichromate (Sodium Bichromate) | | | | B | B | B | C | X | | | | B | B | B | | | C | X | A | A | A | | |
| Sodium Disulfate | | | | X | X | | C | | C | C | C | X | X | B | | C | C | | A | A | | | |
| Sodium Hydroxide (See Caustic Soda) | | | | | | | | | | | | | | | | | | | | | | | |
| Sodium Hypochlorite | | | | X | X | X | X | X | X | X | X | X | X | B | X | X | A | A/X | A | C/A | A | A | Hastelloy® C276 Acceptable |
| Sodium Nitrate | | | | B | B | A | C | C | C | B | B | A | A | A | A | A | A | C | A | A | A | | |
| Sodium Peroxide | | | | B | A | B | C | X | X | B | B | B | B | B | | B | | C | | | A | | |

CONTINUED 

Application Guide

Reference Data

| Corrodant | Boiling Point | Flash Point | Auto Ignition | Iron Steel | Cast Iron Grey | Cast Iron NI Resist | Aluminum | Copper | Lead | Monel® 400 | Nickel 200 | 304, 321, 347 Stainless Steel | 316 Stainless Steel | Type 20 Stainless Steel | Incoloy® 800 | Inconel® 600 | Titanium | Hastelloy® B | Quartz | Graphite | Teflon® | Comments | |
|--|---------------|-------------|---------------|------------|----------------|---------------------|----------|--------|------|------------|------------|-------------------------------|---------------------|-------------------------|--------------|--------------|----------|--------------|--------|----------|---------|--|--------|
| | B.P. °F | F.P. °F | A.I. °F | | | | | | | | | | | | | | | | | | | | |
| Sodium Phosphate | | | | C | C | B | X | B | B | A | C | B | A | B | B | A | A | B | A | A | A | | |
| Sodium Salicylate | | | | B | C | B | | B | B | B | B | B | B | B | B | B | | | A | A | A | | |
| Sodium Silicate | | | | A | B | A | X | B | X | A | A | A | A | A | A | A | A | C | A | A | A | Note 4 | |
| Sodium Stannate | | | | C | C | C | | | | B | B | B | B | B | B | B | | | A | A | A | | |
| Sodium Sulfate | | | | B | C | C/B | B | B | B | B | B | C/X | A/B | B | B | B | C | B | A | A | A | | |
| Sodium Sulfide | | | | C | X | C | C | X | A | B | B | X | C | C | C | C | C | C | C | C | A | A | |
| Solder Bath | | | | X | X | X | X | X | X | X | X | X | X | X | X | X | X | X | | X | X | X | Note 4 |
| Soybean Oil | 540 | 833 | | | | | B | A | | | | A/B | B | B | | | A | A | | | | | |
| Stannostar™ | | | | | | | | | | | | | | | | | | | | A | A | Note 1 TM: The Udylyte Co., OMI Corp., Bright acid tin plating process. | |
| Steam <500°F | | | | A/B | | | A/B | A/B | C | A | A | A/B | B | B | A | A | B | A | | | | | |
| 500–1000°F | | | | C | | | C | C | X | C | C | A | | | A | A | | | | | | | |
| >1000°F | | | | X | | | X | X | | X | X | A | | | A | A | | | | | | | |
| Stearic Acid | 721 | 385 | 743 | C | C | C | C | X | X | B | B | C | A | A/B | B | B | B | A | A | A | A | Hastelloy® C-276 Acceptable | |
| Sugar Solution | | | | A | A | | A | A | A | A | A | A | A | A | A | A | A | | A | A | A | Note 7 | |
| Sulfamate Nickel | | | | | | | | | | | | | | | | | A | A | A | A | A | Note 1 | |
| Sulfur | 832 | 405 | 450 | C | X | C | A | X | X | B | C | C | B | B | A | A | A | X | A | A | A | | |
| Sulfur Chloride | 280 | 245 | 453 | X | X | C | X | X | B | X | C | C | X | C | C | B | X | B | A | X | A | | |
| Sulfur Dioxide | 14 | | | C | C | | C | C | B | X | X | C | B | B | C | C | A | X | A | A | A | | |
| Sulfuric Acid | 626 | | | | | | | | | | | | | | | | | | | | | | |
| <10% Cold | | | | X | | X | C | A | B | B | C | X | C | B | C | X | X | A | | A | A | | |
| Hot | | | | X | X | X | C | X | X | X | X | X | X | X | X | B | X | B | | A | A | | |
| 10–75% Cold | | | | X | | | X | B | B | C | C | X | X | B | B | X | X | A | | A | A | | |
| Hot | | | | X | | | X | X | B | C | X | X | X | C | X | X | X | C | | A | A | | |
| 75–95% Cold | | | | B | B | B | X | B | B | X | X | B | B | B | | | X | C | | A | A | | |
| Hot | | | | X | X | X | X | X | C | X | X | X | X | X | | | X | X | | C | A | | |
| Fuming Sulfurous Acid | | | | C | X | C | X | X | X | X | X | B | C | C | C | C | | C | | | | | |
| Tannic Acid | | 390 | 980 | C | C | C | C/X | C | X | C | C | C | C | A | A | B | A | A | B | A | A | | |
| Tar | | | | A/B | | | A/B | B | | | | A/B | B | B | A | A | | | | | | | |
| Tartaric Acid | | 410 | 802 | | X | B | C | X | C | B | C | C | A | B | A | B | B | B | | A | A | | |
| Tetrachlorethylene (See Perchloroethylene) | | | | | | | | | | | | | | | | | | | | | | | |
| Thermoil Granodine™ | | | | B | | | | | | | | | | | | | | | | | | TM: Amchem Products, Inc. Chemical to produce anti-galling coatings. | |
| Therminol™ FR1–Non Flowing | | | | A | | | | | | | | | | | | | | | | | | TM: Monsanto Co., Heat transfer fluid. | |
| Tin (Molten) | | | | B | B | | X | X | X | X | X | B | B | X | | X | A | | | X | X | Note 4 | |
| Tin-Nickel Plating | | | | | | | | | | | | | | | | | | | | A | A | Note 1 | |
| Tin Plating–Acid | | | | | | | | | | | | | | | | | | | | | A | Note 1 | |
| Tin Plating–Alkaline | | | | A | | | | | | | | A | | | | | | | | | | Note 1 | |

Reference Data

CONTINUED

Application Guide

Reference Data

| Corrodant | Boiling Point | Flash Point | Auto Ignition | Iron Steel | Cast Iron Grey | Cast Iron NI Resist | Aluminum | Copper | Lead | Monel® 400 | Nickel 200 | 304, 321, 347 Stainless Steel | 316 Stainless Steel | Type 20 Stainless Steel | Incoloy® 800 | Inconel® 600 | Titanium | Hastelloy® B | Quartz | Graphite | Teflon® | Comments |
|--|---------------|-------------|---------------|------------|----------------|---------------------|----------|--------|------|------------|------------|-------------------------------|---------------------|-------------------------|--------------|--------------|----------|--------------|--------|----------|---------|--|
| | B.P. °F | F.P. °F | A.I. °F | | | | | | | | | | | | | | | | | | | |
| Toluene | 231 | 40 | 947 | A | A | A | A | C | A | A | A | A | A | A | A | A | A | A | | A | A | Hastelloy® C-276 Acceptable |
| Triad Solvent | | | | C | | | | | | | | | | | | | | | | | | |
| Trichloroethane | | | | A | C | C | B | B | B | B | B | A | B | B | B | B | A | | | A | A | |
| Trichloroethylene | 165 | None | | B | C | C | B | C | X | C | C | B | B | B | B | A | A | A | A | A | A | Hastelloy® C-276 Acceptable |
| Triethylene Glycol | 556 | 350 | 700 | A | A | A | A | A | A | A | A | A | A | A | A | A | A | A | | A | | |
| Trioxide (Pickle) | | | | | | | | | | | | | | | | | | | | | A | Note 1 |
| Trisodium Phosphate | | | | A | A | | X | C | X | C | C | C | C | C | | | | | C | X | B | X |
| Turco™ 2623 | | | | A | | | | | | | | | | | | | | | | | | TM: Turco Products, Div., Purex Corp., Ltd. |
| Turco™ 4008, 4181, 4338 | | | | | | | | | | | | | A | | | | | | | | | Note 1 |
| Turco™ Ultrasonic Solution | | | | | | | | | | | | | A | | | | | | | | | Note 1 |
| Turpentine Oil | 309 -338 | 95 | 488 | C | C | C | A | B | A | A | A | A | A | A | | A | B | B | | | A | A |
| Ubac™ | | | | | | | | | | | | | | | | | | | | A | | Note 1 TM: The Udylite Co., OMI Corp., High leveling acid copper bath. |
| Udylite #66 | | | | | | | | | | | | | | | | | A | | | A | A | Notes 1, 5 |
| Unichrome™ CR-110 | | | | | | | | | | | | | | | | | | | | A | A | Note 1 TM: M & T Chemicals Inc., Plating Process, supplies and equipment. |
| Unichrome™ 5RHS | | | | | | | | | | | | | | | | | | | | A | A | Note 1 |
| Vegetable Oil | | 610 | | C | | C | B | X | X | A | A | A | A | A | A | | A | B | | | A | A |
| Vinegar | | | | C | | | C | | | A | | B | A/B | B | | | A | B | | | A | A |
| Water (Fresh) | | | | X | C | A | A | A | A | A | A | C | C | A | A | A | A | | | A | A | |
| Water (Deionized) (See Deionized Water) | | | | | | | | | | | | | | | | | | | | | | |
| Water (Sea) (See Sea Water) | | | | | | | | | | | | | | | | | | | | | | |
| Watt's Nickel Strike | | | | | | | | | | | | | | | | | | | | | A | Note 1 |
| Whiskey and Wines | | | | X | | C | | A | | A | A | A | A | A | A | A | A | A | | | A | A |
| Wood's Nickel Strike | | | | | | | | | | | | | | | | | | | | | A | Note 1 |
| Yellow Dichromate | | | | | | | | | | | | | A | | | | | | | | A | Note 1 |
| X-Ray Solution | | | | | | | | | | | | A | | | | | | | | | | |
| Zinc (Molten) | 1664 | | | | | | X | X | X | X | X | X | X | X | X | X | X | X | | | | X |
| Zinc Chloride | 1350 | | | C | C | C | X | X | B | B | B | X | X | B | X | B | C | B | | A | A | A |
| Zinc Phosphate | | | | | | | | | | | | | A | | | | | | | | | X Notes 1, 5 |
| Zinc Plating Acid | | | | | | | | | | | | | | | | | | | | | A | |
| Zinc Plating Cyanide | | | | A | | | | | | | | A | | | | | | | | | | Note 1 |
| Zinc Sulfate | | | | C | X | A | C | B | A | B | C | C | C | C | | B | A | C | | | A | A |
| Zincate™ | | | | A | | | | | | | | A | | | | | | | | | | Note 1 TM: Ashland Chemical, Alkaline salt for immersion zinc plating aluminum. |

Application Guide

Reference Data Energy Calculations

Ref. 139

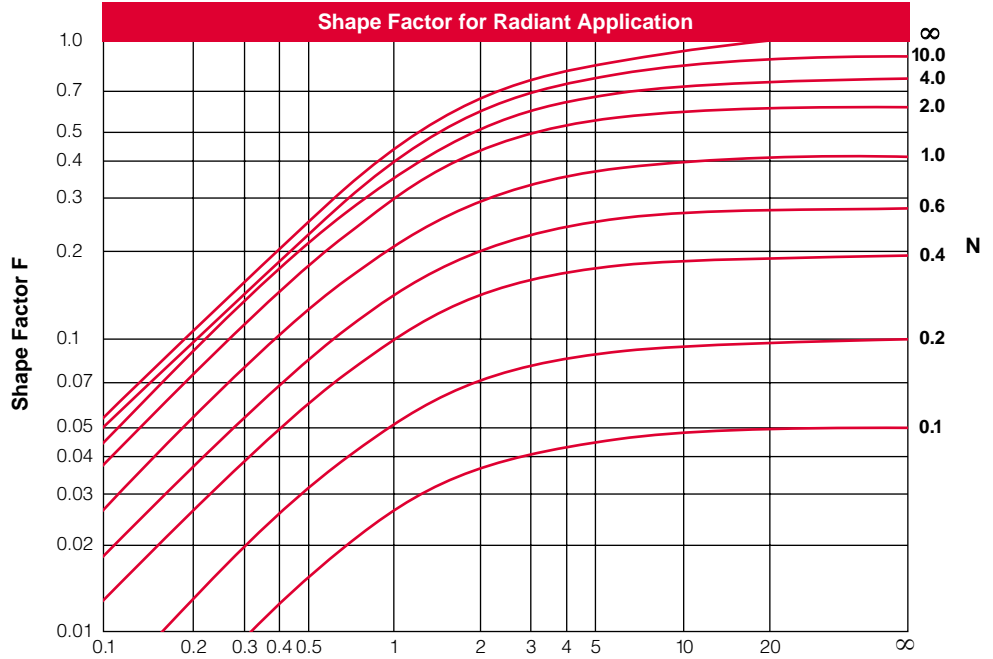

For Two Facing Panels: $N = \left(\frac{\text{Heated Length}}{\text{Distance to Material}} \right)$ $M = \left(\frac{\text{Heated Width}}{\text{Distance to Material}} \right)$

Ref. 140

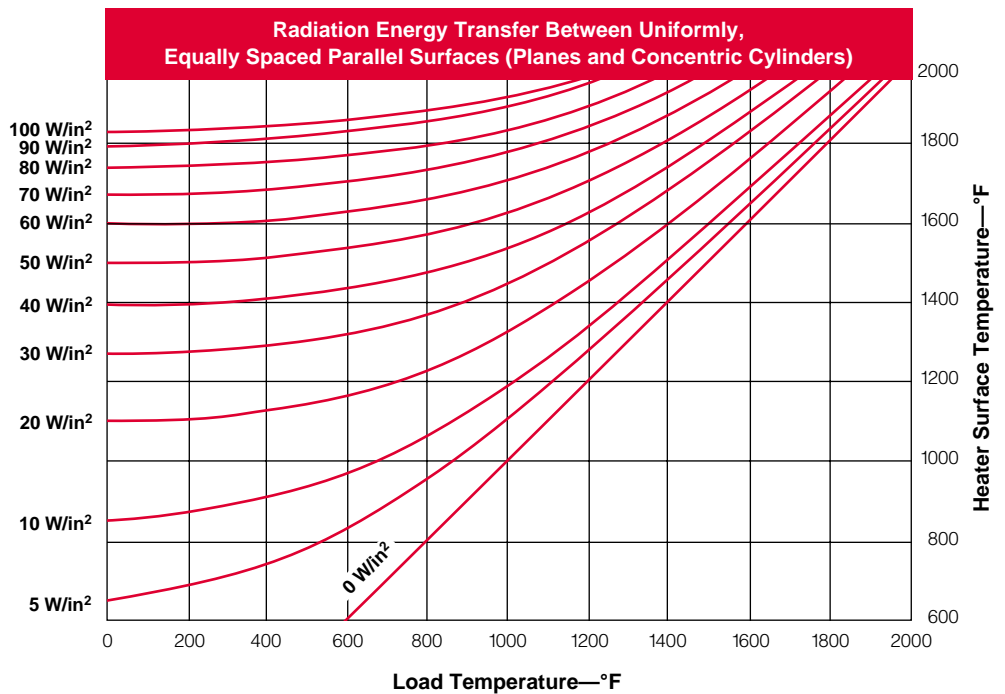

Application Guide

Reference Data

Examples of Applications

Objective

An insulated steel cabinet located outdoors on a concrete pad contains an electronic control system for outdoor signaling equipment. The cabinet is three feet wide, two feet deep and four feet high with a two-inch thickness of insulation applied to the outer surfaces. Under the worst conditions the cabinet is exposed to temperatures of -20°F and 20 MPH winds. The objective is to provide heating to maintain the electrical equipment above the freezing temperature. The control system normally consumes 75 watts of power but must be protected even when not in operation. A terminal strip within the cabinet provides 120 volt, single-phase power.

Power Requirements

For this application, we only need to be concerned with how much power is required to make up the cabinet's heat losses. The heat losses are continuous assuming a worst case situation (-20°F and 20 mph winds).

Cabinet Freeze Protection

Ref. 141

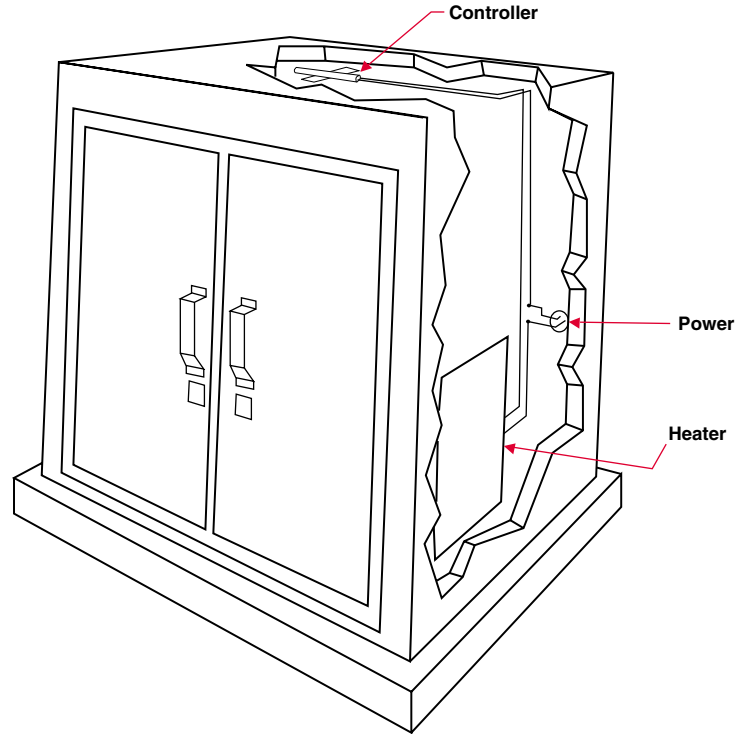

Determine Thermal System Heat Losses

- Conduction. Heat losses through the concrete base are negligible using Equation 3A, (Page 17).
- Combined convection and radiation—losses from exposed surfaces—From Equation 3D, (Page 18).

$$Q_{L4} = A \cdot F_{SL} \cdot t_e$$
$$= (6624 \text{ in}^2) \cdot (0.03 \text{ W/in}^2) \cdot (2.75) \cdot (1 \text{ hr})$$

$$Q_L = 546 \text{ Wh}$$

where:

$$A = \text{the exposed surface area}$$
$$= 2 \text{ ft} \cdot 3 \text{ ft} + 2 \cdot (3 \text{ ft} \cdot 4 \text{ ft}) + 2 \cdot (2 \text{ ft} \cdot 4 \text{ ft}) = 46 \text{ ft}^2$$
$$= 6624 \text{ in}^2$$

$$\Delta T = \text{temperature difference} = 32^\circ\text{F} - (-20^\circ\text{F})$$
$$= 52^\circ\text{F}$$

F_{SL} = the heat loss coefficient for 2 inch insulation at $\Delta T = 52^\circ\text{F}$ from Ref. 12, page 28 = 0.03 W/in² multiplied by the wind velocity correction factor at 20 mph (2.75 from Ref. 16, Page 29). Since Ref. 12, Page 28 is based on 70°F ambient rather than -20°F, find the coefficient at an equivalent temperature of 122°F

$$t_e = \text{the exposure time} = 1 \text{ hour}$$

Application Guide

Reference Data

Examples of Applications

Continued

Calculate Operating Power Requirements

From Equation 5, (Page 18) using a 10 percent safety factor,

$$\begin{aligned} \text{Operating Power} &= \left[\frac{Q_B + Q_D}{t_c} + \frac{Q_L}{t_e} \right] \cdot (1 + \text{S.F.}) \\ &= \frac{546 \text{ Wh}}{1 \text{ hr}} \cdot 1.1 = 601 \text{ W} \end{aligned}$$

where:

$$Q_B = 0$$

$$Q_D = 0$$

$$Q_L = 546 \text{ Wh}$$

$$t_c = \text{assume 1 hour}$$

$$t_e = 1 \text{ hour}$$

Cabinet Freeze Protection Power Evaluation

Ref. 142

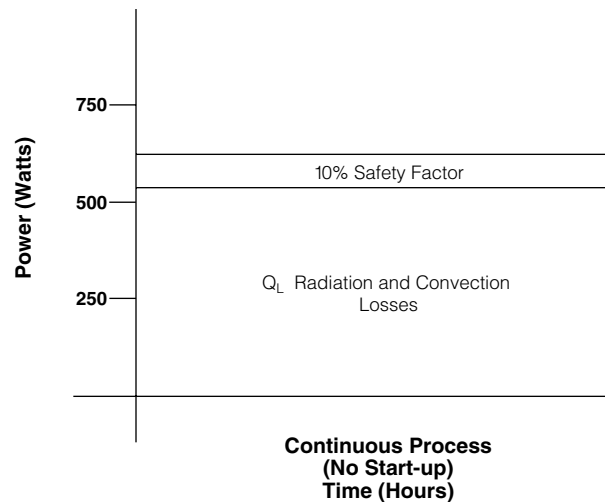

Heater Recommendation

A flexible silicone rubber heater six inch X 20 inch rated at 600 watts, 120 volts mounted near the bottom of the cabinet provides a simple and inexpensive solution for enclosure heating. The heater may be ordered with a pressure sensitive adhesive surface for easy mounting.

Control

This application requires only very simple control to ensure the insulated steel cabinet maintains a preset temperature above freezing. A Watlow basic controller preset to 40°F will protect the cabinet above the freezing point.

Application Guide

Reference Data

Examples of Applications

Continued

Objective

A mild steel compression mold is used to form plastic parts. Two-ounce charges of plastic at room temperature are inserted at a rate of 30 per hour. The steel mold is six inch X nine inch X six inch overall and is placed between two steel platens, each 10 inch X 15 inch X two inch. The platens are insulated from the press with ½ inch thick rigid insulation board. The mold must be pre-heated to 350°F in 45 minutes while closed. Room temperature is 70°F.

Power Requirements

The following steps illustrate the calculations to estimate the power in watts needed for initial heating and to maintain the operating temperature.

Heating a Steel Mold

Ref. 143

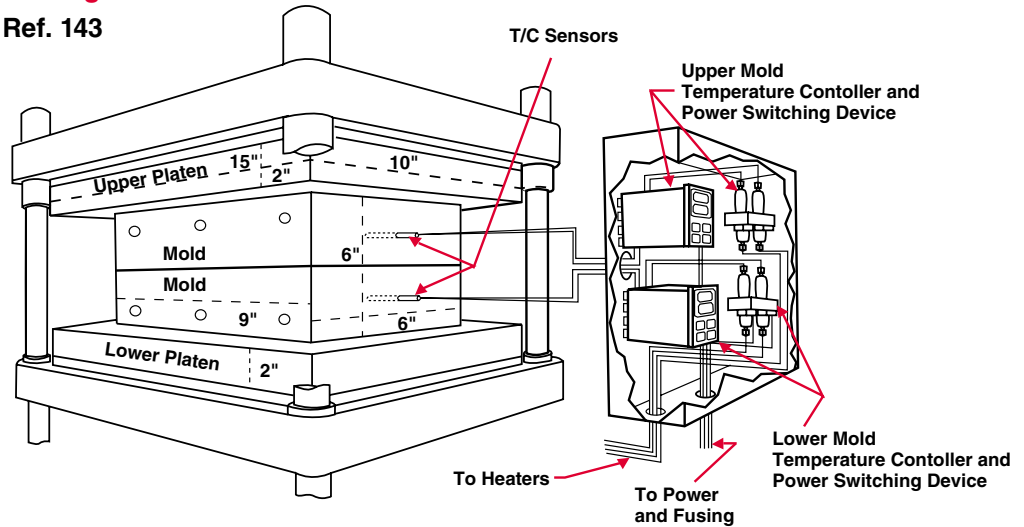

Step 1: Initial Heating of the Mold and Platens

From Equation 1, (Page 16).

$$\begin{aligned}
 Q_A &= \frac{w \cdot C_p \cdot \Delta T}{3.412} \\
 &= \frac{(263 \text{ lbs}) \cdot (0.12 \text{ Btu/lb} \cdot \text{°F}) \cdot (280\text{°F})}{3.412 \text{ Btu/Wh}} \\
 &= 2590 \text{ Wh}
 \end{aligned}$$

where:

$$\begin{aligned}
 w &= \text{weight of mold and platens} \\
 &= \text{volume (in}^3\text{) x density (lbs/in}^3\text{)} \\
 &= [(6 \text{ in.} \cdot 9 \text{ in.} \cdot 6 \text{ in.}) + 2 \cdot (10 \text{ in.} \cdot 15 \text{ in.} \cdot 2 \text{ in.})] (0.284 \text{ lbs/in}^3) \\
 &= 263 \text{ lbs}
 \end{aligned}$$

$$C_p = \text{specific heat of steel} = 0.12 \text{ Btu/lb} \cdot \text{°F}$$

$$\Delta T = \text{temperature rise} = 350\text{°F} - 70\text{°F} = 280\text{°F}$$

Application Guide

Reference Data

Examples of Applications

Continued

Step 2: Heating of Plastic During the Operating Cycle

From Equation 1, (Page 16).

$$Q_B = \frac{(0.125 \text{ lbs}) \cdot (0.4 \text{ Btu/lb} \cdot ^\circ\text{F}) \cdot (280^\circ\text{F})}{3.412 \text{ Btu/Wh}}$$

$$= 4.1 \text{ Wh}$$

where:

w = weight of plastic charge = 2 oz. = 0.125 lb

C_p = specific heat of plastic = 0.4 Btu/lb · °F

ΔT = temperature rise = 280 °F

Step 3: Heat Required to Melt or Vaporize Materials During Initial Heating

Not required since plastic is not present during initial heat-up.

$$Q_C = 0$$

Step 4: Heat Required to Melt or Vaporize Materials During the Operating Cycle

Not required since the plastic does not change phase during the molding operation.

$$Q_D = 0$$

Step 5: Determine Thermal System Heat Losses

Energy is required to replace heat lost to conduction, convection and radiation:

a. Conduction losses through the insulated surfaces

From Equation 3A, (Page 17).

$$Q_{L1} = \frac{K \cdot A \cdot \Delta T \cdot t_e}{3.412 \cdot L}$$

$$= \frac{(5.2 \text{ Btu} \cdot \text{in.}/\text{ft}^2 \cdot ^\circ\text{F} \cdot \text{hr}) \cdot (2.08 \cdot \text{ft}^2) \cdot (280^\circ\text{F}) \cdot (1 \text{ hr})}{(3.412 \text{ Btu/Wh}) \cdot (0.5 \text{ in.})}$$

$$= 1775 \text{ Wh}$$

where:

K = the thermal conductivity of ½ inch rigid insulation board
= 5.2 Btu · inch/hr · ft² · °F

A = The total insulated surface area
= $\frac{2 \cdot (10 \cdot 15) \text{ in}^2}{144 \text{ in}^2/1\text{ft}^2} = 2.08 \text{ ft}^2$

ΔT = the temperature differential between the heated platen and the outside insulation at ambient = 350°F - 70°F = 280°F

L = the insulation thickness = 0.5 inch

t_e = exposure time = 1 hour

Application Guide

Reference Data

Examples of Applications

Continued

b. Convection losses

From Equation 3B, (Page 17).

$$Q_{L2} = A \cdot F_{SL} \cdot C_F \cdot t_e$$

Sides:

$$\begin{aligned} Q_{L2} &= (180 \text{ in}^2 + 200 \text{ in}^2) \cdot (0.64 \text{ W/in}^2) \cdot (1 \text{ hr}) \\ &= 243 \text{ Wh} \end{aligned}$$

where:

F_{SL} = the surface loss factor for a vertical surface at 350°F is 0.64 W/in² from Reference 9, (Page 26)

$$\begin{aligned} A_1 &= \text{mold side area} = 2 \cdot (6 \text{ in.} \cdot 6 \text{ in.}) = 2 \cdot (6 \text{ in.} \cdot 9 \text{ in.}) \\ &= 180 \text{ in}^2 \end{aligned}$$

$$\begin{aligned} A_2 &= \text{platen side area} = 4 \cdot (2 \text{ in.} \cdot 10 \text{ in.}) + 4 \cdot (2 \text{ in.} \cdot 15 \text{ in.}) \\ &= 200 \text{ in}^2 \end{aligned}$$

C_F = correction factor = 1.0

t_e = exposure time = 1 hr

Bottom (of the top platen):

$$\begin{aligned} Q_{L2} &= (96 \text{ in}^2) \cdot (0.64 \text{ W/in}^2) \cdot (0.63) \cdot (1 \text{ hr}) \\ &= 39 \text{ Wh} \end{aligned}$$

where:

$$\begin{aligned} A &= \text{exposed platen area} = (10 \text{ in.} \cdot 15 \text{ in.}) - (6 \text{ in.} \cdot 9 \text{ in.}) \\ &= 96 \text{ in}^2 \end{aligned}$$

F_{SL} = 0.64 W/in²

C_F = the correction factor for bottom surfaces (0.63 from Reference 9, Page 26)

t_e = exposure time = 1 hr

Top (of the bottom platen):

$$\begin{aligned} Q_{L2} &= (96 \text{ in}^2) \cdot (0.64 \text{ W/in}^2) \cdot (1.29) \cdot (1 \text{ hr}) \\ &= 79 \text{ Wh} \end{aligned}$$

where:

C_F = the correction factor for top surfaces (1.29 from Reference 9, Page 26)

Application Guide

Reference Data

Examples of Applications

Continued

c. Radiation losses

From Equation 3C, (Page 17)

$$\begin{aligned} Q_{L3} &= A \cdot F_{SL} \cdot e \cdot t_e \\ &= (572 \text{ in}^2) \cdot (1.3 \text{ W/in}^2) \cdot (0.75) \cdot (1 \text{ hr}) \\ &= 558 \text{ Wh} \end{aligned}$$

where:

A = the total surface area of mold sides, platen sides and exposed platen top and bottom is 572 in²

F_{SL} = the blackbody radiation loss factor at 350°F is 1.3 W/in² from Reference 9 (Page 26)

e = the emissivity of mild steel with a medium oxide finish (0.75 from Reference 10 (Page 27))

t_e = exposure time = 1 hr

d. Total heat losses

From Equation 3E, (Page 18)

| | |
|----------------------|---------|
| Conduction | 1775 Wh |
| Convection–sides | 243 |
| Convection–bottom | 39 |
| Convection–top | 79 |
| Radiation | 558 |
| Total Q _L | 2694 Wh |

Step 6: Calculate Start-Up Power Requirements

Start-up power is required for initial heating of the mold and platens, to compensate for losses during start-up plus a 10 percent safety factor.

From Equation 4, (Page 18)

$$\begin{aligned} \text{Start-Up Power} &= \left[\frac{Q_A + Q_C}{t_s} + \frac{2}{3} \left(\frac{Q_L}{t_e} \right) \right] \cdot (1 + \text{S.F.}) \\ &= \left[\left(\frac{2590 \text{ Wh}}{0.75 \text{ hr}} \right) + \frac{2}{3} \left(\frac{2694 \text{ Wh}}{1 \text{ hr}} \right) \right] \cdot (1.1) \\ &= 5774 \text{ watts} \end{aligned}$$

where:

Q_A = initial heating of mold and platens
= 2590 Wh

Q_C = latent heat = 0

Q_L = heat losses = 2694 Wh

t_s = start-up time = 0.75 hours

t_e = exposure time for losses = 1 hr

S.F. = safety factor = 10%

Application Guide

Reference Data

Examples of Applications

Continued

Step 7: Calculate Operating Power Requirements

Operating Power is required to heat each plastic charge and to compensate for operating losses. From Equation 5, (Page 18) using a 10 percent safety factor,

$$\begin{aligned} \text{Operating Power} &= \left[\frac{Q_B + Q_D}{t_c} + \frac{Q_L}{t_e} \right] \cdot (1 + \text{S.F.}) \\ &= \left[\left(\frac{4.1 \text{ Wh}}{0.0333 \text{ hrs}} \right) + \left(\frac{2694 \text{ Wh}}{1 \text{ hr}} \right) \right] \cdot (1.1) \\ &= 3099 \text{ watts} \end{aligned}$$

where:

Q_B = Heating of plastic during operation = 4.1 Wh

Q_D = Latent heat = 0

Q_L = Heat losses = 2694 Wh

t_c = Cycle time at 30 charges per hour = 0.0333 hrs

t_e = Exposure time for losses = 1 hr

S.F. = Safety factor = 10%

Heating a Steel Mold Power Evaluation

Ref. 144

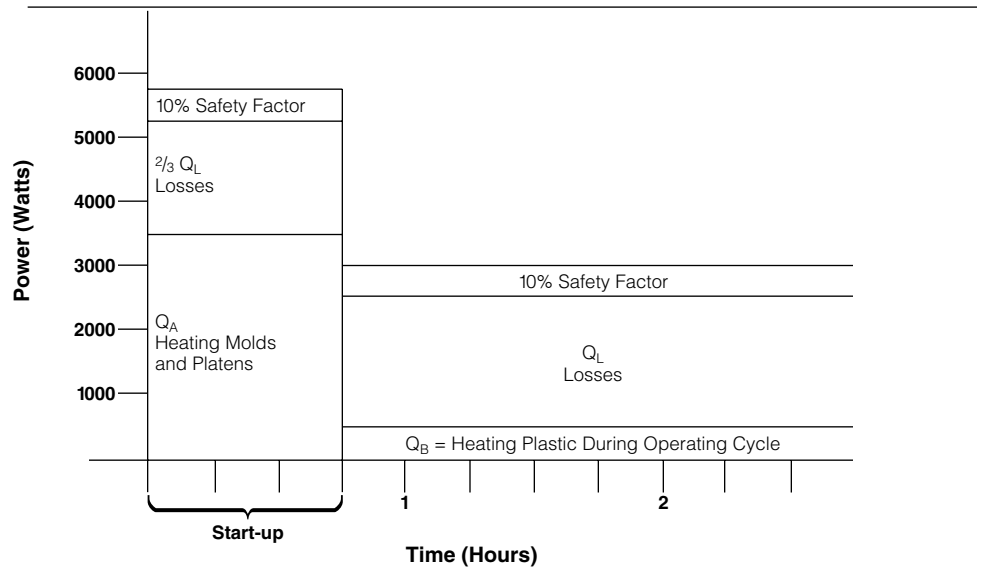

Application Guide

Reference Data

Examples of Applications

Continued

Heater Recommendation

Heating capacity is determined by either the start-up power requirement or the operating power needed, whichever is larger. In this case, a minimum of 5700 watts is required. Heater selection is dictated by a number of factors including efficiency, even heat distribution, watt density and availability.

Since heating efficiency is optimized by heating the mold from within, six cartridge heaters inserted into holes drilled in the molds are recommended. The heaters are stock ½ inch diameter X six inch length FIREROD® heaters rated 1000 watts at 240 volts. Three heaters each in the top and bottom molds should be arranged to surround the cavity. Holes will be drilled completely through the mold to facilitate heater removal.

Hole Fit and Watt Density

A normal tolerance for a ½ inch drilled hole is ± 0.005 inch; and the diameter of a standard ½ inch FIREROD cartridge heater is slightly undersized at 0.496 inch ± 0.002 inch. Therefore the worst-case clearance or “fit” is 0.011 inch (0.505 – 0.494 inch). Assuming close temperature control with frequent on-off cycling of the heater, the maximum watt density

should be derated to 126 W/in² using a 0.7 multiplier. The recommended ½ inch X six inch, 1000 watt heaters are rated at 117 W/in² which is within the maximum of 126 W/in² for this application. Therefore the heaters are conservatively rated and should yield extended life.

Environmental Factors

The biggest single cause of heater failure is contamination. This contamination can come from many sources such as lubricating oil, cleaning solvents, plastic material or fumes, organic tapes, etc. As a heater cools down, it “inhales” these contaminants. Upon reaching the heated zone, the contaminants carbonize causing electrical arcing and failure.

The heaters may be specified with a Teflon® seal or with silicone rubber potting in the lead end of the heater

to protect against contamination. Both are effective at 400°F. For higher temperature applications MI lead assemblies are available.

In addition, stainless steel hose, stainless steel braid or galvanized BX conduit may be ordered with the heaters to protect the leads against abrasion. Either right angle or straight terminations are available for wiring convenience.

Control

The heaters may be controlled individually, or as a group, depending on the need for precision in temperature and heat distribution. The plastic molding material itself and the configuration of the molded part will dictate the level of temperature precision and heat distribution precision necessary. A Type J thermocouple is used as standard sensor for plastics molding. This application demands narrow temperature control. Two PID temperature controllers, one for the top and one for the bottom, plus a

separate power switching device for each, will do the job. The Watlow SERIES SD with a DIN-A-MITE® power controller is the recommended control solution. The SERIES SD offers auto-tuning or manually-set PID values, as well as a configurable alarm output. Two SERIES SDs, with switched DC output, in conjunction with two Watlow DIN-A-MITE controllers control the heaters.

Application Guide

Reference Data

Examples of Applications

Continued

Objective

Design a furnace to melt at least 250 lbs of aluminum ingots per hour and raise the crucible, furnace and aluminum to a working temperature of 1350°F in five hours using ceramic fiber heaters. The aluminum is held in a 1000 lb capacity silicon carbide crucible. The crucible is 26 inches in diameter at the top, 18 inches in diameter at the bottom and 24 inches in height. Wall thickness is two inches. The crucible rests on a silicon carbide pedestal four inches thick. The crucible and pedestal together weigh 300 lbs. Ambient temperature is 70°F.

Furnace Construction

The inside diameter of the furnace should be 30 inches, that is, an air gap between furnace wall and crucible of two inches, or four inches larger than the crucible diameter. Ceramic fiber heaters include two inch thick insulation and are surrounded by four inches of additional back-up insulation. The overall diameter is 42 inches. Total furnace height is 34 inches allowing 24 inches for the crucible, four inches for the pedestal, two inches for a hearth and four inches for the cover. Approximately 20 cubic feet of insulating material is included. The chassis shell is constructed of 1/8 inch thick steel.

Power Requirements

The following steps illustrate how to calculate the power in watts needed for initial heating of the aluminum, crucible and furnace assembly. Also, the power required to maintain the holding temperature, and the power required to melt 250 lb/hr of aluminum on a continuous basis.

Melting of Aluminum

Ref. 145

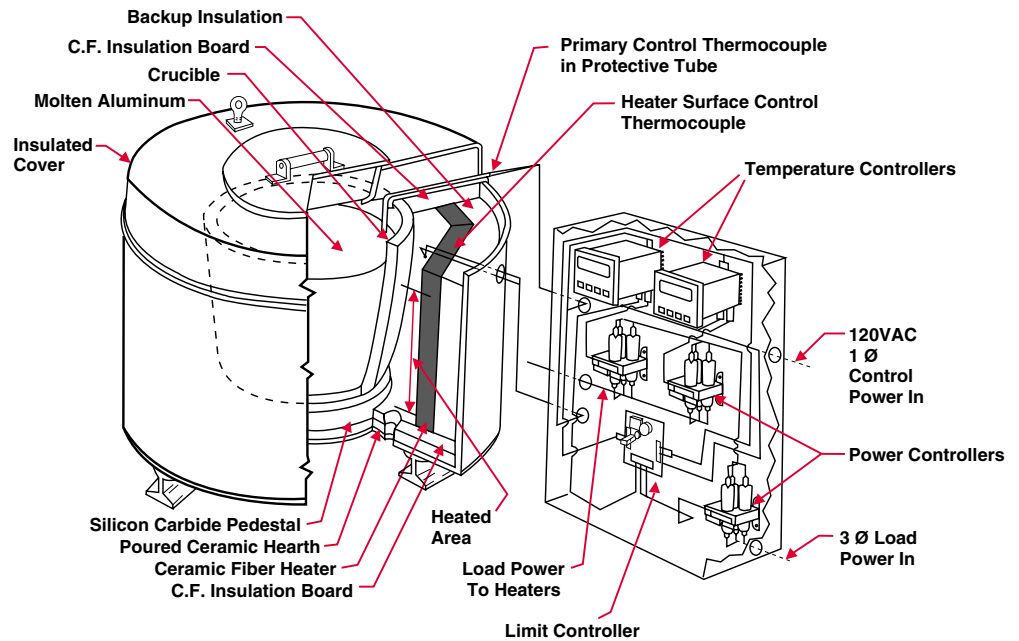

Step 1: Initial Heating and Melting of Aluminum, Initial Heating of Crucible and Furnace

a. Aluminum from ambient to 1080°F, the melting temperature of a typical aluminum alloy

Using Equation 1, (Page 16)

$$\begin{aligned}
 Q_A &= \frac{w \cdot C_p \cdot \Delta T}{3.412} \\
 &= \frac{(1000 \text{ lbs}) \cdot (0.24 \text{ Btu/lb} \cdot ^\circ\text{F}) \cdot (1010^\circ\text{F})}{3.412 \text{ Btu Wh}} \\
 &= 71,043 \text{ Wh}
 \end{aligned}$$

where:

w = aluminum weight = 1000 lbs

C_p = specific heat of solid aluminum
= 0.24 Btu/lb · °F

ΔT = temperature rise = 1080°F - 70°F = 1010°F

Application Guide

Reference Data

Examples of Applications

Continued

b. Heat required to melt the aluminum during start-up

From Equation 2, (Page 16)

$$\begin{aligned} Q_C &= \frac{w \cdot H_f}{3.412} \\ &= \frac{(1000 \text{ lbs}) \cdot (167 \text{ Btu/lb})}{3.412 \text{ Btu/Wh}} \\ &= 48,945 \text{ Wh} \end{aligned}$$

where:

w = weight of aluminum = 1000 lbs

H_f = aluminum heat of fusion = 167 Btu/lb

c. Aluminum from 1080°F to the casting temperature of 1350°F

$$\begin{aligned} Q_A &= \frac{w \cdot C_p \cdot \Delta T}{3.412} \\ &= \frac{(1000 \text{ lbs}) \cdot (0.26 \text{ Btu/lb} \cdot ^\circ\text{F}) \cdot (270^\circ\text{F})}{3.412 \text{ Btu/Wh}} \\ &= 20,574 \text{ Wh} \end{aligned}$$

where:

w = weight of aluminum = 1000 lbs

ΔT = 1350°F - 1080°F = 270°F

C_p = 0.26 Btu/lb · °F for molten aluminum

d. Crucible and pedestal

$$\begin{aligned} Q_A &= \frac{(300 \text{ lbs}) \cdot (0.19 \text{ Btu/lb} \cdot ^\circ\text{F}) \cdot (1380^\circ\text{F})}{3.412 \text{ Btu/Wh}} \\ &= 23,054 \text{ Wh} \end{aligned}$$

where:

w = weight of crucible and pedestal = 300 lbs

C_p = specific heat of silicon carbide used
= 0.19 Btu/lb · °F

ΔT = 1450°F - 70°F = 1380°F (From experience, the average crucible temperature will be about 100°F hotter than the molten aluminum).

Application Guide

Reference Data

Examples of Applications

Continued

e. Insulation

$$\begin{aligned} Q_A &= \frac{w \cdot C_p \cdot \left(\frac{T_1 + T_2}{2} \right) \cdot \Delta T}{3.412} \\ &= \frac{(300 \text{ lbs}) \cdot (0.27 \text{ Btu/lb} \cdot ^\circ\text{F}) \cdot (880^\circ\text{F})}{3.412 \text{ Btu/Wh}} \\ &= 20,891 \text{ Wh} \end{aligned}$$

where:

density of ceramic fiber insulation = 15 lbs/ft³

w = weight of insulation = volume • density
= 20 ft³ • 15 lbs/ft³ • 300 lbs

C_p = specific heat of insulation = 0.27 Btu/lb • °F

T₁ = heater surface temperature

= approx. 1700°F from experience. The actual heater temperature is calculated in later paragraphs.

T₂ = chassis temperature = 200°F From "Insulation Effectiveness" on page 146 of the Watlow Heaters catalog. Use the graph at 1700°F heater temperature and 6 inch insulation.

T_A = average insulation temperature

$$= \frac{T_1 + T_2}{2} = 950^\circ\text{F}$$

ΔT = average temperature rise

$$= T_A - 70^\circ\text{F} = 880^\circ\text{F}$$

f. Chassis and structure

$$\begin{aligned} Q_A &= \frac{(258 \text{ lbs} + 200 \text{ lbs}) \cdot (0.122 \text{ Btu/lb} \cdot ^\circ\text{F}) \cdot (130^\circ\text{F})}{3.412 \text{ Btu/Wh}} \\ &= 2129 \text{ Wh} \end{aligned}$$

where:

density of steel = 490 lbs/ft³ = 0.284 lbs/in³

w₁ = weight of steel chassis shell

= surface area • thickness • density

$$= (7257 \text{ in}^2) \cdot (0.125 \text{ in.}) \cdot (0.284 \text{ lbs/in}^3)$$

$$= 258 \text{ lbs}$$

w₂ = weight of additional steel supports, brackets, mounting pads

= 200 lbs (assume)

C_p = specific heat of steel used = 0.122 Btu/lb • F

ΔT = temperature rise = 200°F - 70°F = 130°F

Application Guide

Reference Data

Examples of Applications

Continued

g. Total for initial heating:

| | | |
|-----------------------------------|---|------------|
| aluminum to 1080°F | = | 71,043 Wh |
| aluminum from 1080°F to 1350°F | = | 20,574 Wh |
| crucible and pedestal | = | 23,054 Wh |
| insulation | = | 20,891 Wh |
| chassis and structure | = | 2,129 Wh |
| <hr/> | | |
| Total Q _A | = | 137,691 Wh |
| Total Q _C | = | 48,945 Wh |

Step 2: Heating and Melting of Aluminum During Operating Cycle

a. Heat aluminum to the melting point

From Equation 1, (Page 16).

$$\begin{aligned}
 Q_B &= \frac{w \cdot C_p \cdot \Delta T}{3.412} \\
 &= \frac{(250 \text{ lbs}) \cdot (0.24 \text{ Btu/lb} \cdot ^\circ\text{F}) \cdot (780^\circ\text{F})}{3.412 \text{ Btu/Wh}} \\
 &= 13,716 \text{ Wh}
 \end{aligned}$$

where:

w = 250 lbs of aluminum ingots

ΔT = 1080°F - 300°F. Aluminum ingots are preheated to 300°F to eliminate moisture on the aluminum ingots.

b. Heat required to melt the aluminum during the operating cycle

From Equation 2, (Page 16).

$$\begin{aligned}
 Q_D &= \frac{w \cdot H_f}{3.412} \\
 &= \frac{(250 \text{ lbs}) \cdot (167 \text{ Btu/lb})}{3.412 \text{ Btu/lb}} \\
 &= 12,236 \text{ Wh}
 \end{aligned}$$

c. Heat aluminum from melting point to operating temperature

From Equation 1, (Page 16).

$$\begin{aligned}
 Q_B &= \frac{w \cdot C_p \cdot \Delta T}{3.412} \\
 &= \frac{(250 \text{ lbs}) \cdot (0.26 \text{ Btu/lb} \cdot ^\circ\text{F}) \cdot (270^\circ\text{F})}{3.412 \text{ Btu/Wh}} \\
 &= 5,144 \text{ Wh}
 \end{aligned}$$

d. Total for operating cycle

$$Q_B = 13,716 + 5,144 = 18,860 \text{ Wh}$$

$$Q_D = 12,236 \text{ Wh}$$

Application Guide

Reference Data

Examples of Applications

Continued

Step 3: Determine Thermal System Heat Losses

Power is required to replace heat energy lost from the surfaces of the furnace by convection and radiation. Using Equation 3D, ([Page 18](#)).

a. Side losses

Experience has shown that during long melting cycles, the internal heater wire temperature rises, which in turn raises the side surface temperatures of the furnace.

$$\begin{aligned}Q_{L4} &= A \cdot F_{SL} \cdot t_e \\ &= (4486 \text{ in}^2) \cdot (1.0 \text{ W/in}^2) \cdot (1 \text{ hr}) \\ &= 4486 \text{ Wh}\end{aligned}$$

where:

$$\begin{aligned}A &= \text{side surface area} = 42 \text{ in. dia} \cdot \pi \cdot 34 \text{ in. height} \\ &= 4486 \text{ in}^2\end{aligned}$$

$$\begin{aligned}F_{SL} &= \text{surface loss factor for the chassis at } 260^\circ\text{F} \\ &\quad (\text{an increase of } 60^\circ\text{F during melting}) \\ &= 1.0 \text{ W/in}^2\end{aligned}$$

$$t_e = \text{exposure time for losses} = 1 \text{ hr}$$

b. Top losses

$$\begin{aligned}Q_{L4} &= A \cdot F_{SL} \cdot C_F \cdot t_e \\ &= (1385 \text{ in}^2) \cdot (0.4 \text{ W/in}^2) \cdot (1.29) \cdot (1 \text{ hr}) \\ &= 715 \text{ Wh}\end{aligned}$$

where:

$$\begin{aligned}A &= \text{top surface area} = (42 \text{ in. dia}/2)^2 \cdot \pi \\ &= 1385 \text{ in}^2\end{aligned}$$

$$\begin{aligned}F_{SL} &= \text{surface loss factor for the top surface at } 170^\circ\text{F} \\ &\quad (170^\circ\text{F from page 146 of the Watlow Heater's catalog for an inside} \\ &\quad \text{surface temperature of } 1350^\circ\text{F and four inch insulation.)} \\ &= 0.4 \text{ W/in}^2 \text{ (Ref. 9, see } \text{Page 26} \text{ for oxidized steel)}\end{aligned}$$

$$C_F = \text{top surface correction factor of } 1.29$$

$$t_e = \text{exposure time for losses} = 1 \text{ hr}$$

Application Guide

Reference Data

Examples of Applications

Continued

c. Bottom losses

$$\begin{aligned} Q_{L4} &= A \cdot F_{SL} \cdot C_F \cdot t_e \\ &= (1385 \text{ in}^2) \cdot (0.95 \text{ W/in}^2) \cdot (0.63) \cdot (1 \text{ hr}) \\ &= 829 \text{ Wh} \end{aligned}$$

where:

$$\begin{aligned} A &= 1385 \text{ in}^2 \text{ (previously calculated)} \\ F_{SL} &= \text{surface loss factor for a surface at } 250^\circ\text{F} \\ &\quad \text{(bottom temperature = } 250^\circ\text{F; assume hotter than top or sides} \\ &\quad \text{due to pedestal and poured ceramic hearth)} \\ &= 0.95 \text{ W/in}^2 \\ C_F &= \text{bottom surface correction factor of } 0.63 \\ t_e &= \text{exposure time for losses = } 1 \text{ hr} \end{aligned}$$

d. Open furnace cover losses

Opening and closing of the furnace cover to add additional ingots, causes significant power losses. The 22 inch diameter skin of the molten aluminum in a full crucible, the upper edges of the exposed crucible and other surfaces are all sources of heat losses when the cover is open. Assuming the cover is opened and closed several times per hour, we can say that the cover is open for 10 minutes during a one hour period. From Equation 3D, (Page 18).

$$\begin{aligned} Q_{L4} &= A \cdot F_{SL} \cdot t_e \\ &= (380 \text{ in}^2) \cdot (13 \text{ W/in}^2) \cdot (0.167 \text{ hr}) \\ &= 825 \text{ Wh} \end{aligned}$$

where:

$$\begin{aligned} A &= \text{molten aluminum surface area} \\ &= (22 \text{ in. dia}/2)^2 \cdot \pi \\ &= 380 \text{ in}^2 \\ F_{SL} &= \text{surface loss factor from Reference 13 (Page 28) at } 1080^\circ\text{F} \\ &= 13 \text{ W/in}^2 \\ t_e &= 10 \text{ minutes} = 0.167 \text{ hr} \end{aligned}$$

e. Total losses

$$\begin{aligned} \text{Sides} &= 4486 \cdot \text{Wh} \\ \text{Top} &= 715 \cdot \text{Wh} \\ \text{Bottom} &= 829 \cdot \text{Wh} \\ \text{Open Lid} &= 825 \cdot \text{Wh} \\ \text{Total } Q_L &= 6855 \cdot \text{Wh} \end{aligned}$$

Application Guide

Reference Data

Examples of Applications

Continued

Step 4: Calculate Start-Up Power Requirements

From Equation 4, (Page 18).

$$\begin{aligned}\text{Start-Up Power} &= \left[\frac{Q_A + Q_C}{t_s} + \frac{2}{3} \left(\frac{Q_L}{t_e} \right) \right] \cdot (1 + \text{S.F.}) \\ &= \frac{137,691 + 48,945 \text{ Wh}}{5 \text{ hrs}} + \frac{2}{3} \left(\frac{6855 \text{ Wh}}{1 \text{ hr}} \right) \cdot (1) \\ &= 41,900 \text{ watts}\end{aligned}$$

where:

$$Q_A = 137,691 \text{ Wh}$$

$$Q_C = 48,945 \text{ Wh}$$

$$Q_L = 6855 \text{ Wh}$$

$$t_s = \text{start-up time} = 5 \text{ hrs}$$

$$t_e = \text{exposure time for losses} = 1 \text{ hr}$$

$$\text{S.F.} = 0 \text{ for this example}$$

Step 5: Calculate Operating Power Requirements

From Equation 5, (Page 18).

$$\begin{aligned}\text{Operating Power} &= \left[\frac{Q_B + Q_D}{t_c} + \frac{Q_L}{t_e} \right] \cdot (1 + \text{S.F.}) \\ &= \frac{18,860 + 12,236 \text{ Wh}}{1 \text{ hr}} + \frac{6855 \text{ Wh}}{1 \text{ hr}} \cdot (1) \\ &= 37,950 \text{ watts}\end{aligned}$$

where:

$$Q_B = 18,860 \text{ Wh}$$

$$Q_D = 12,236 \text{ Wh}$$

$$Q_L = 6855 \text{ Wh}$$

$$t_c = \text{cycle time} = 1 \text{ hr}$$

$$t_e = \text{exposure time for losses} = 1 \text{ hr}$$

$$\text{S.F.} = 0 \text{ for this example}$$

Application Guide

Reference Data

Examples of Applications

Continued

Heater Recommendation

Twelve standard eight inch X 24 inch high watt density, flat ceramic fiber heaters arranged in a circle around the crucible will form an inside diameter of about 30 inches. Each eight inch X 24 inch heater with sinuated wire elements is rated at 3600 watts with furnace hot face temperatures up to 1800°F. Twelve heaters will produce 43,200 watts.

Heater Performance Limits Verification

It is necessary to verify the element operating temperature and insure that the load can absorb the energy produced by the heaters fast enough to prevent heater damage.

First, use the heat transfer equation for thermal conductivity through the crucible to calculate the outside surface temperature of the crucible. Then use the radiant heat transfer equation to calculate the heater element temperature.

Note that the thermal conductivity of new silicon carbide is reasonably good at $K = 112$. However, as the crucible ages, thermal conductivity can decrease drastically to as little as 20 percent of original value. A 50 percent decrease in the thermal conductivity will cause the ΔT across the crucible to double, simply to conduct the same amount of heat. This must be considered when designing the furnace and its control system.

Melting of Aluminum Power Evaluation

Ref. 146

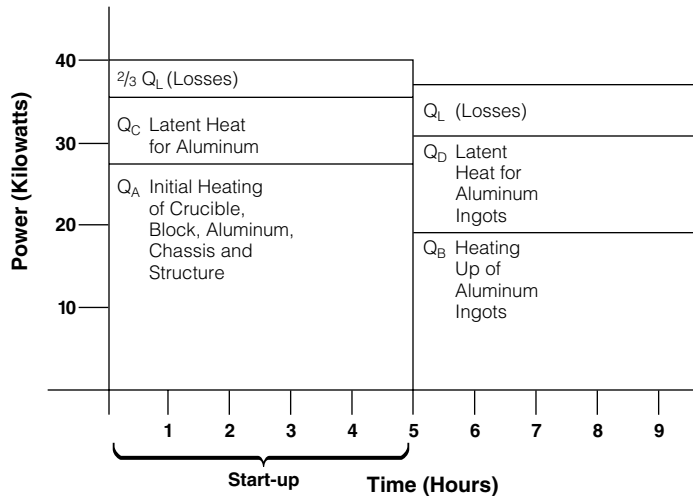

Crucible Surface Temperature

From Equation 3A, (Page 17) heat energy conducted through the crucible:

$$Q = \frac{K \cdot A \cdot T_{\Delta} \cdot t_e}{3.412 \cdot L}$$

Solve for T_{Δ}

$$\begin{aligned} \Delta T &= \frac{Q}{t_e} \cdot \frac{3.412 \cdot L}{K \cdot A} = T_1 - T_2 \\ &= \frac{(35,445 \text{ W}) \cdot (3.412 \text{ Btu/Wh}) \cdot (2 \text{ in.})}{(112 \text{ Btu} \cdot \text{in./hr} \cdot \text{ft}^2 \cdot \text{°F}) \cdot (13.5 \text{ ft}^2)} = 160\text{°F} \end{aligned}$$

$$\text{Then } T_1 = T_2 + \Delta T = 1510\text{°F}$$

where:

$\frac{Q}{t_e}$ = power available to melt the aluminum. This is calculated by subtracting heat losses during operation from the rated power of the heaters.

$$= 42,300 - 6855 = 35,445 \text{ W}$$

L = crucible thickness = 2 in.

K = thermal conductivity of silicon carbide = 112 Btu - in./hr - ft² - °F (From Ref. 132, Page 134)

A = crucible surface area = 13.5 ft²

T_1 = crucible outside surface temperature

T_2 = crucible inside surface temperature = 1350°F

Application Guide

Reference Data

Examples of Applications

Continued

Since the equation was originally written for equal size parallel plates, and we are dealing essentially with concentric cylinders, the proportional differences between the different diameters must be factored into the analysis. The ratio (R) takes this into account when the outer cylinder (the heater, or source) radiates heat toward the inner cylinder (the load). The shape factor (F) is assumed to be one as end effects are negligible near the center of the crucible's height.

The best heat transfer condition occurs where there are small differences in the shape/size of the source and load. Where the differences are large, the temperature of the source must be significantly higher to transfer the same amount of heat energy.

For this crucible application, the best heat transfer condition occurs where the crucible diameter is largest. Similarly, the heat transfer near the bottom of bowl shaped crucibles is poorest. Generally, design should be based upon the worst case condition, however, for this example, we can ignore this situation, since convection effects cause the heat to rise from the bottom of the bowl area, thus equalizing the energy flow between heater and crucible.

Heater Surface Temperature

From Equation 6, (Page 19) the heat energy radiated from the heater to the crucible:

$$\text{Watt Density} = \frac{Q}{t_e \cdot A} = \frac{S \cdot (T_2^4 - T_1^4) \cdot \left(\frac{1}{\frac{1}{e_1} + \frac{1}{e_2} - 1} \right) \cdot F}{144 \cdot 3.412}$$

For concentric cylinders, this equation becomes:

$$\text{Power (watts)} = \frac{Q}{t_e} = \frac{S \cdot A \cdot (T_1^4 - T_2^4) \cdot \left(\frac{1}{\frac{1}{e_1} + R \cdot \frac{1}{e_2} - 1} \right)}{144 \cdot 3.412}$$

Now, solving for the heater element temperature T₁:

$$T_1^4 = T_2^4 + \frac{Q \cdot (144) \cdot (3.412)}{t_e \cdot S \cdot A} \cdot \left(\frac{1}{\frac{1}{e_1} + R \cdot \frac{1}{e_2} - 1} \right)$$

$$T_1 = 2146^\circ\text{R} = 1686^\circ\text{F}$$

where:

$$\frac{Q}{t_e} = \text{power radiated to the crucible} = 35,445 \text{ watts}$$

$$S = \text{Stefan-Boltzman constant} \\ = 0.1714 \times 10^{-8} \text{ Btu/hr} \cdot \text{ft}^2 \cdot ^\circ\text{R}^4$$

$$T_1 = \text{heating element temperature}$$

$$T_2 = \text{crucible outside surface temperature} \\ = 1510^\circ\text{F} = 1970^\circ\text{R}$$

$$e_1 = \text{heater emissivity} = 0.88$$

$$e_2 = \text{silicon carbide crucible emissivity} = 0.92$$

$$D_1 = \text{heater diameter} = 30 \text{ in.}$$

$$D_2 = \text{crucible diameter} = 26 \text{ in.}$$

$$R = \frac{D_1}{D_2} = \frac{30}{26} = 1.1538$$

$$A = \text{heater surface area} = 12 \cdot 8 \text{ in.} \cdot 24 \text{ in.} \\ = 2304 \text{ in}^2$$

To transfer 35,445 watts to the load, the heater must operate at 1686°F which is below the heater rating of 1800°F.

Application Guide

Reference Data

Conclusion

From the example presented here, it appears that the system will function well. It is important to note that all of the permutations have not been considered in this example. To insure satisfactory performance and life, the aging characteristics of the crucible must also be considered. Over a long

period of time, reduced thermal conductivity will require that a higher crucible surface temperature is required to get heat transfer to the aluminum. As the crucible temperature must increase, the heater temperature must also increase.

From a practical standpoint, small differences in diameters have little

effect on the heater temperatures. Larger differences (especially at small sizes) can have a marked effect. Emissivities of the various surfaces can also have important effects on the resultant heater temperatures. It is important to use values that are accurate, or to test prototypes during the design and development stage.

Control Requirements

Design—The aluminum crucible requires a unique control system, a design with cascaded control outputs, which not only controls aluminum temperature via “hold” and “high melt” heaters, but also controls the surface temperature of the heaters themselves. In addition, high and low limit control must provide fail-safe protection for the crucible and the aluminum charge.

Primary Control—A Watlow SERIES 988 microprocessor based control is the recommended primary control for the crucible. The SERIES 988 has a dual output, heat PID-heat on-off configuration with a Type N thermocouple sensor in a protective tube in the molten aluminum. The Type N thermocouple is excellent for long sensor life at high temperatures. The 988 controls half of the 12 heaters

with Set Point 1 at 1350°F and the other set of six heaters with on-off Set Point 2 at a differential 20°F less. A Watlow DIN-A-MITE® switches power to each set of heaters. In addition, to extend the life of the two sets of heaters, a special set point interchange switch enables monthly rotation. The hold heaters become the boost heaters and vice versa.

Heater Surface Control—To further protect the ceramic fiber heaters a second thermocouple is used to monitor the face temperature of the heaters. This sensor is connected to input 2 of the 988 which is set up for cascade control. The rH2 value, range high Z is set to limit the heater to a maximum temperatures of 1800°F. The Type N thermocouple sensor is placed directly against the heater face.

High and Low Limit Control—

Because both over- and undertemperatures are potentially damaging to the crucible system and the aluminum charge, a Watlow limit controller with a mercury displacement relay is used to ensure fail-safe protection for the system. The limit controller takes a Type K thermocouple input. It will sever power to the heaters at 1825°F heater surface temperature, and turn on a red strobe alarm. Low alarm input comes directly from the input terminals of the SERIES 988. At 1200°F, the low limit SP of the 988 will also activate the red strobe indicator. A feature of the SERIES 988 allows a low alarm condition to be ignored on start-up.

Application Guide

Reference Data

Examples of Applications

Continued

Objective

A manufacturing process requires nitrogen gas which is supplied from standard steel gas cylinders. The system operates at low pressure, below 120 psi, and the cylinders must be heated to 140°F. A steel tank 52 inches long X 14 inches wide X 40 inches high holds four cylinders plus 48 gallons of heated water. The tank weighs 100 lbs and is covered with two inch thick insulation.

One hour is allowed for preheating the tank, water bath and two gas cylinders. Two additional nitrogen cylinders are then put into the bath and allowed to warm-up for 15 minutes as the first pair is used. They are then used during the following 15 minutes while the next pair is warming up and so on. Each cylinder weighs 55 lbs empty and 65 lbs when full. Ambient temperature is 70°F. Power available is 240 volts, 3-phase.

Power Requirements

The following steps illustrate the calculations to estimate the power required to preheat the system, to heat the gas cylinders and to replace heat losses.

Heating Liquid in a Tank

Ref. 147

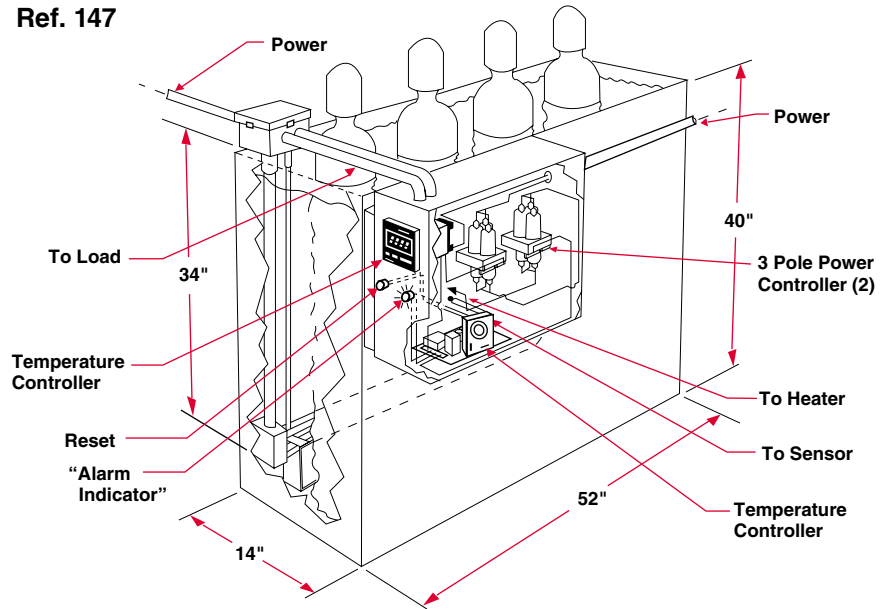

Step 1: Initial Heating of Tank, Water and Gas Cylinders

From Equation 1, (Page 16)

a. Tank

$$\begin{aligned}
 Q_A &= \frac{w \cdot C_p \cdot \Delta T}{3.412} \\
 &= \frac{(100 \text{ lbs}) \cdot (0.12 \text{ Btu/lb} \cdot ^\circ\text{F}) \cdot (70^\circ\text{F})}{3.412 \text{ Btu/Wh}} \\
 &= 246 \text{ Wh}
 \end{aligned}$$

where:

w = weight of tank = 100 lbs

C_p = specific heat of steel = 0.12 Btu/lb · °F

ΔT = temperature rise = 140°F - 70°F = 70°F

b. Water

$$\begin{aligned}
 Q_A &= \frac{(400 \text{ lbs}) \cdot (1.0 \text{ Btu/lb} \cdot ^\circ\text{F}) \cdot (70^\circ\text{F})}{3.412 \text{ Btu/Wh}} \\
 &= 8206 \text{ Wh}
 \end{aligned}$$

where:

w = weight of water = volume · density
 = 48 gal · $\frac{1 \text{ ft}^3}{7.48 \text{ gal}}$ · 62.3 lbs/ft³ = 400 lbs

C_p = specific heat of water = 1.0 Btu /lb · °F

ΔT = 70°F

Application Guide

Reference Data

Examples of Applications

Continued

c. Gas cylinders

The energy requirements of both the steel cylinder and nitrogen gas must be calculated.

Steel cylinder:

$$Q_A = \frac{(55 \text{ lbs}) \cdot (0.12 \text{ Btu/lb} \cdot ^\circ\text{F}) \cdot (70^\circ\text{F})}{3.412 \text{ Btu/Wh}}$$

$$= 135 \text{ Wh}$$

where:

w = weight of each cylinder = 55 lbs

Cp = specific heat of steel = 0.12 Btu/lb · °F

ΔT = 70°F

Nitrogen gas:

$$Q_A = \frac{(10 \text{ lbs}) \cdot (0.249 \text{ Btu/lb} \cdot ^\circ\text{F}) \cdot (70^\circ\text{F})}{3.412 \text{ Btu/Wh}}$$

$$= 51 \text{ Wh}$$

where:

w = weight of nitrogen = 10 lbs

CP = specific heat of nitrogen = 0.249 Btu/lb · °F

ΔT = 70°F

Total for two gas cylinders:

$$Q_A = 2 \cdot (135 + 51) = 372 \text{ Wh}$$

d. Total

$$Q_A = 246 + 8206 + 372$$

$$= 8824 \text{ Wh}$$

Step 2: Heating of Gas Cylinders During the Operating Cycle

Since two gas cylinders are used for each cycle, refer back to Step 1, part c.

$$Q_B = 2 \cdot (135 + 51)$$

$$= 372 \text{ Wh}$$

Step 3: Heat Required to Melt or Vaporize Materials During Start-Up

Not required as no materials change phase.

$$Q_C = 0$$

Step 4: Heat Required to Melt or Vaporize Materials During Operating Cycle

Not required as no materials change phase.

$$Q_D = 0$$

Application Guide

Reference Data

Examples of Applications

Continued

Step 5: Determine Thermal System Heat Losses

a. Convection and radiation losses from insulated tank

From Equation 3D, (Page 18)

$$\begin{aligned} Q_{L4} &= A \cdot F_{SL} \cdot t_e \\ &= (5280 \text{ in}^2) \cdot (0.03 \text{ W/in}^2) \cdot (1 \text{ hr.}) \\ &= 158 \text{ Wh} \end{aligned}$$

where:

$$\begin{aligned} A &= \text{exposed surface area} \\ &= (2 \cdot 14 \text{ in.} \cdot 40 \text{ in.}) + (2 \cdot 52 \text{ in.} \cdot 40 \text{ in.}) = 5280 \text{ in}^2 \\ F_{SL} &= \text{surface loss factor for 2 inch insulation at } \Delta T = 70^\circ\text{F} \\ &= 0.03 \text{ W/in}^2 \\ t_e &= \text{exposure time} = 1 \text{ hour} \end{aligned}$$

b. Convection and radiation losses from water surface

From Equation 3D, (Page 18).

$$\begin{aligned} Q_{L4} &= (728 \text{ in}^2) \cdot (1.7 \text{ W/in}^2) \cdot (1 \text{ hr}) \\ &= 1238 \text{ Wh} \end{aligned}$$

where:

$$\begin{aligned} A &= \text{water surface area} = 14 \text{ in.} \cdot 52 \text{ in.} = 728 \text{ in}^2 \\ F_{SL} &= \text{surface loss factor for water at } 140^\circ\text{F} \\ &= 1.7 \text{ W/in}^2 \end{aligned}$$

c. Total Losses

$$Q_L = 158 + 1238 = 1396 \text{ Wh}$$

Step 6: Calculate Start-Up Power Requirements

From Equation 4, (Page 18) using a 10 percent safety factor,

$$\begin{aligned} \text{Start-Up Power} &= \left[\frac{Q_A + Q_C}{t_s} + \frac{2}{3} \left(\frac{Q_L}{t_e} \right) \right] \cdot (1 + \text{S.F.}) \\ &= \left[\left(\frac{8824 + 0 \text{ Wh}}{1 \text{ hr}} \right) + \frac{2}{3} \left(\frac{1396 \text{ Wh}}{1 \text{ hr}} \right) \right] \cdot (1.1) \\ &= 10,730 \text{ W} \end{aligned}$$

where:

$$\begin{aligned} Q_A &= 8824 \text{ Wh} \\ Q_C &= 0 \\ Q_L &= 1396 \text{ Wh} \\ t_s &= \text{start-up time} = 1 \text{ hour} \\ t_e &= \text{exposure time for losses} = 1 \text{ hour} \\ \text{S.F.} &= \text{safety factor} = 10 \text{ percent} \end{aligned}$$

Application Guide

Reference Data

Examples of Applications

Continued

Step 7: Calculate Operating Power Requirements

From Equation 5, (Page 18) using a 10 percent safety factor,

$$\begin{aligned} \text{Operating Power} &= \left[\frac{Q_B + Q_D}{t_c} + \frac{Q_L}{t_e} \right] \cdot (1 + \text{S.F.}) \\ &= \left[\frac{372 \text{ Wh}}{0.25 \text{ hr}} + \frac{1396 \text{ Wh}}{1 \text{ hr}} \right] \cdot (1.1) \\ &= 3172 \text{ W} \end{aligned}$$

where:

$$Q_B = 372 \text{ Wh}$$

$$Q_D = 0$$

$$Q_L = 1396 \text{ Wh}$$

$$t_c = \text{cycle time} = 15 \text{ min.} = 0.25 \text{ hr}$$

$$t_e = 1 \text{ hr}$$

$$\text{S.F.} = \text{safety factor} = 10 \text{ percent}$$

Heater Recommendation

The heating requirement is determined by either the start-up or the operating power, whichever is greater. In this case 10.7 kilowatts are required for start-up.

A stock 12 kilowatts over-the-side immersion heater is recommended; an "L"-shaped configuration with Incoloy® elements rated at 48 W/in². The element length is about 38 inches and is spaced four inches above the bottom of the tank. The elements should be protected against damage by the gas cylinders.

Control

The control requirements here do not demand a high degree of controllability. The 48 gallons of water represent a large thermal mass; overshoot is not anticipated, nor is it a problem. The Watlow SERIES SD digital indicating control with PID and auto-tuning is the recommended controller. In addition, a Watlow limit controller will protect the heater when the tank is empty. A Watlow DIN-A-MITE power controller will provide power-switching for the SERIES SD.

Heating Liquid in a Tank Power Evaluation

Ref. 148

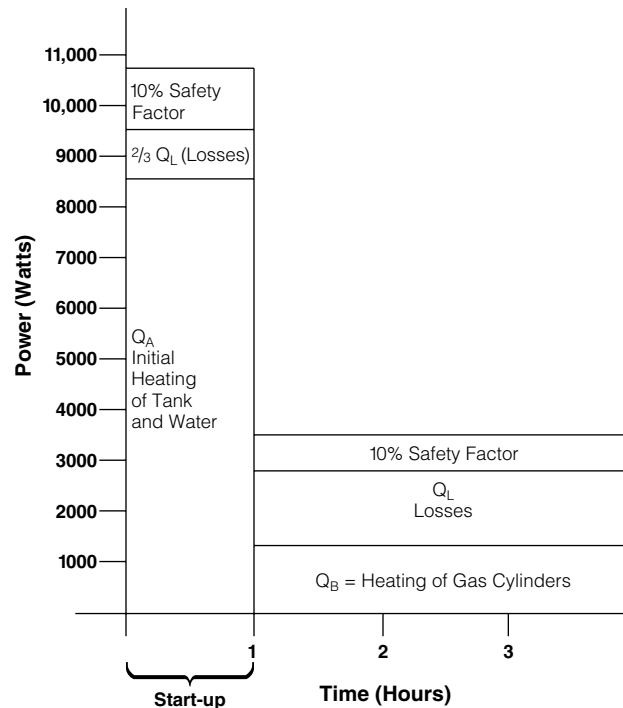

Incoloy® is a registered trademark of the Special Metals Corporation.

Application Guide

Reference Data

Examples of Applications

Continued

Objective

A waste water treatment plant requires heating four gallons per minute of treatment water from 70-150°F. The water contains traces of electrolytic cleaners, so it is contained in a 36 inch diameter by 84 inch tall, 350 gallon polypropylene receiver tank. A four inch -150 lb mating flange is available at the bottom of the tank. The customer has expressed concern about the possibility of corrosion, and requests a lower watt density heater rated at 50 kW.

Heating a Flowing Liquid

Ref. 149

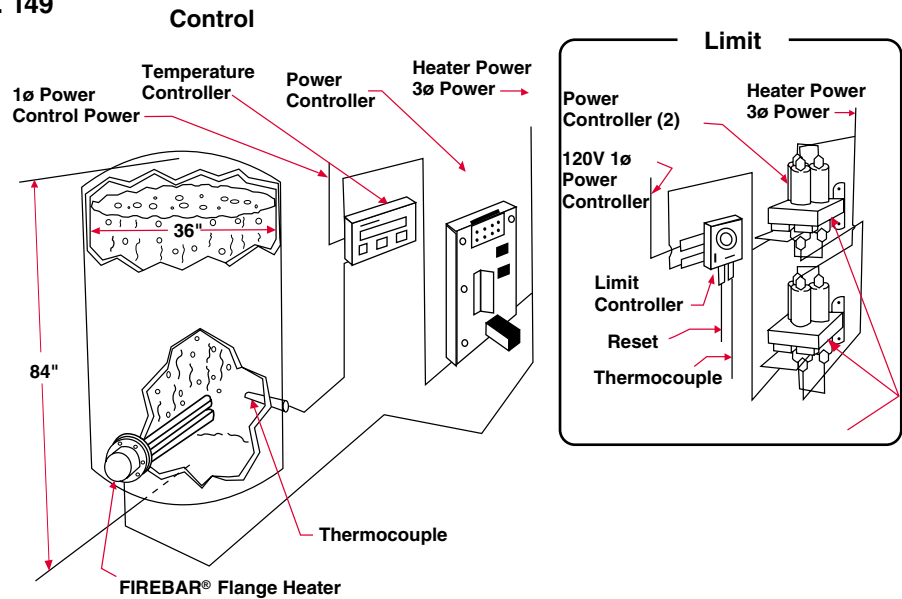

Step 1: Initial Heating of the Water and Tank

Because the process is a continuous operation, there will not normally be any start-up period. When the process is interrupted for periodic maintenance though, a maximum of 12 hours for heat-up is requested. With this long of a start-up period, it is likely that the normal operating power will meet this requirement, but it is always advisable to check. From Equation 1, (Page 16).

a. Tank

The tank is made of polypropylene and we will assume it is an insulator, so heat-up of tank will be negligible.

b. Water

$$Q_A = \frac{w \cdot C_p \cdot \Delta T}{3.412}$$

$$= \frac{(2915 \text{ lbs}) \cdot (1.0 \text{ Btu/lb} \cdot ^\circ\text{F}) \cdot (80^\circ\text{F})}{3.412 \text{ Btu/Wh}}$$

$$Q_A = 68,350 \text{ Wh}$$

where:

w = weight of water = volume \cdot density

$$= (350 \text{ gal}) \cdot \left(\frac{1 \text{ ft}^3}{7.48 \text{ gal}} \right) \cdot \left(\frac{62.3 \text{ lbs}}{1 \text{ ft}^3} \right)$$

$$= 2915 \text{ lbs}$$

C_p = specific heat of water = 1.0 Btu/lb \cdot $^\circ\text{F}$

$$\Delta T = 150^\circ\text{F} - 70^\circ\text{F} = 80^\circ\text{F}$$

Application Guide

Reference Data

Examples of Applications

Continued

Step 2: Heating of Water During the Operating Cycle

The following is the energy needed to heat the treatment water during actual operation. Even though the customer has specified a given value, it is advisable to check that rate with the given process parameters. From Equation 1, (Page 16).

$$\begin{aligned} Q_B &= \frac{w \cdot C_p \cdot \Delta T}{3.412} \\ &= \frac{(2000 \text{ lbs}) \cdot (1.0 \text{ Btu/lb} \cdot ^\circ\text{F}) \cdot (80^\circ\text{F})}{3.412 \text{ Btu/Wh}} \\ &= 46,890 \text{ Wh} \end{aligned}$$

where:

$$\begin{aligned} w &= \text{weight of water per hour} \\ &= \text{volume} \cdot \text{density} \\ &= (4 \text{ gpm}) \cdot (60 \text{ min}) \cdot \left(\frac{1 \text{ ft}^3}{7.48 \text{ gal}} \right) \cdot \left(\frac{62.3 \text{ lbs}}{1 \text{ ft}^3} \right) \\ &= 2000 \text{ lbs/hr} \end{aligned}$$

$$C_p = \text{specific heat of water} = 1.0 \text{ Btu/lb} \cdot ^\circ\text{F}$$

$$\Delta T = 150^\circ - 70^\circ = 80^\circ\text{F}$$

Step 3: Heat Required to Melt or Vaporize Materials During Initial Heating

Not required since the water does not change phase.

$$Q_C = 0$$

Step 4: Heat Required to Melt or Vaporize Materials During Operating Cycle

Not required since the water does not change phase.

$$Q_D = 0$$

Step 5: Determine Thermal System Heat Losses

Because polypropylene is a poor thermal conductor, we will assume it acts as an insulator, and use one inch of insulation as an equivalent value. From Equation 3D, (Page 18).

$$\begin{aligned} Q_{L4} &= A \cdot F_{SL} \cdot t_e \\ &= (10,520 \text{ in}^2) \cdot (0.05 \text{ W/in}^2) \cdot (12 \text{ hrs}) \\ Q_L &= 6312 \text{ Wh} \end{aligned}$$

where:

$$\begin{aligned} A &= \text{exposed surface area} \\ &= (36 \text{ in.} \cdot \pi \cdot 84 \text{ in.}) + \left[\frac{\pi \cdot (36 \text{ in.})^2}{4} \right] \\ &= 10,520 \text{ in}^2 \end{aligned}$$

$$\begin{aligned} F_{SL} &= \text{surface loss factor for 1 inch insulation at } \Delta T = 80^\circ\text{F} \\ &= 0.05 \text{ W/in}^2 \end{aligned}$$

$$t_e = \text{exposure time} = 12 \text{ hrs}$$

Application Guide

Reference Data

Examples of Applications

Continued

Step 6: Calculate Start-Up Power Requirements

From Equation 4 (Page 18), using a 10 percent safety factor,

$$\begin{aligned}\text{Start-Up Power} &= \left[\frac{Q_A + Q_C}{t_s} + \frac{2}{3} \left(\frac{Q_L}{t_e} \right) \right] \cdot (1 + \text{S.F.}) \\ &= \left[\left(\frac{68,350 \text{ Wh}}{12 \text{ hrs}} \right) + \frac{2}{3} \left(\frac{6312 \text{ Wh}}{12 \text{ hrs}} \right) \right] \cdot (1.1) \\ &= 6050 \text{ W}\end{aligned}$$

where:

$$Q_A = 68,350 \text{ Wh}$$

$$Q_C = 0$$

$$Q_L = 6312 \text{ Wh}$$

$$t_s = \text{start-up time} = 12 \text{ hrs}$$

$$t_e = \text{exposed time} = 12 \text{ hrs}$$

$$\text{S.F.} = \text{safety factor} = 10\%$$

Step 7: Calculate Operating Power Requirements

From Equation 5 (Page 18), using 10 percent safety factor,

$$\begin{aligned}\text{Operating Power} &= \left[\frac{Q_B + Q_D}{t_c} + \frac{Q_L}{t_e} \right] \cdot (1 + \text{S.F.}) \\ &= \frac{46,890 \text{ Wh}}{1 \text{ hr}} + \frac{526 \text{ Wh}}{1 \text{ hr}} \cdot (1.1) \\ &= 52,100 \text{ watts} = 52.1 \text{ kW}\end{aligned}$$

where:

$$Q_B = 46,890 \text{ Wh}$$

$$Q_D = 0$$

Q_L = during operation, losses are evaluated on a per hour basis, therefore:

$$(10,520 \text{ in}^2) \cdot (0.05 \text{ W/in}^2) \cdot (1 \text{ hr}) = 526 \text{ Wh}$$

$$t_c = \text{cycle time required} = 1 \text{ hr}$$

$$t_e = \text{exposure time} = 1 \text{ hr}$$

$$\text{S.F.} = \text{safety factor} = 10\%$$

Application Guide

Reference Data

Examples of Applications

Continued

Heater Recommendation

The customer's requested value of 50 kilowatts appears to be correct. This specific installation will limit our choices to a four inch-150 lb flange heater with a maximum immersed length of 36 inches. A traditional approach would be a four inch flange with six 0.475 inch diameter tubular elements. The watt density would be:

$$W/in^2 = \frac{5000 W}{1 hr} = 93 W/in^2$$

where:

$$W/in^2 = \frac{W}{\text{active heater surface area}}$$

$$= \frac{\text{heated length}}{\text{element}} [\text{in.}] \cdot \frac{\text{surface area}}{\text{element}} \cdot \left[\frac{\text{in}^2}{\text{in.}} \right] \cdot \frac{\text{elements}}{\text{flange}}$$

$$\text{heated length} = (30 \text{ inches immersed}) \cdot (2 \text{ lengths/element})$$

$$\text{surface area for } 0.475 \text{ inch diameter} = 1.49 \text{ in}^2/\text{in.}$$

$$\begin{aligned} \text{surface area} &= (30 \text{ in.}) \cdot (2) \cdot (1.49 \text{ in}^2/\text{in.}) \cdot (6 \text{ elements}) \\ &= 536 \text{ in}^2 \end{aligned}$$

Control

A SERIES SD is used to switch a power controller which in turn switches the heaters. A limit controller is used with a mechanical contactor as over temperature protection.

Heating a Flowing Liquid Power Evaluation

Ref. 150

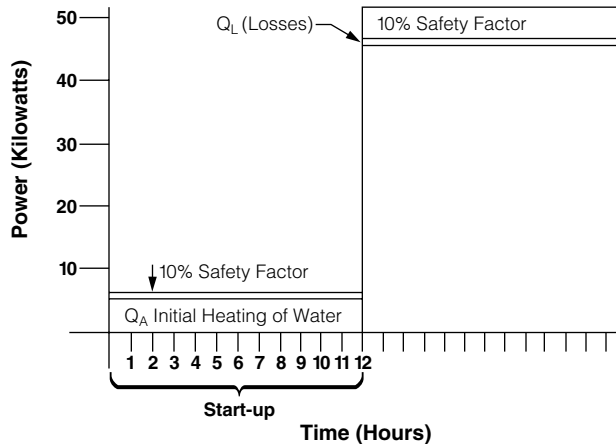

Compare this traditional approach to a FIREBAR® flange heater, with six FIREBAR elements.

$$W/in^2 = 60.4 = \frac{50,000 \text{ watts}}{828 \text{ in}^2}$$

where:

$$\text{surface area for FIREBAR} = 2.3 \text{ in}^2/\text{in.}$$

$$\begin{aligned} \text{surface area} &= (30 \text{ in.}) \cdot (2) \cdot (2.3 \text{ in}^2/\text{in.}) \cdot (6 \text{ element}) \\ &= 828 \text{ in}^2 \end{aligned}$$

Clearly the FIREBAR® flange heater provides a better solution with a 35 percent reduction in watt density. Incoloy® elements and a 304 stainless steel flange will be used because of the traces of corrosive cleaners.

Application Guide

Reference Data

Examples of Applications

Continued

Objective

A drying process for unfired ceramics requires 780 cubic feet per minute (CFM) of air at $560^{\circ}\text{F} \pm 20^{\circ}\text{F}$. The air temperature at the blower exit is 90°F and the air is delivered to the dryer through a duct 19 feet in length. The duct is 22 inches wide X 15 inches high and is wrapped with four inch thick insulation.

The equipment layout dictates that the duct heaters may be located no closer than 12 feet to the dryer. The plant ambient temperature is 70°F . Power available is 240/480 volt three-phase or single phase.

Power Requirements

The following steps illustrate the calculations to estimate the heat needed for the process air and to compensate for duct losses. There is no start-up heating required.

Air Duct Heater

Ref. 151

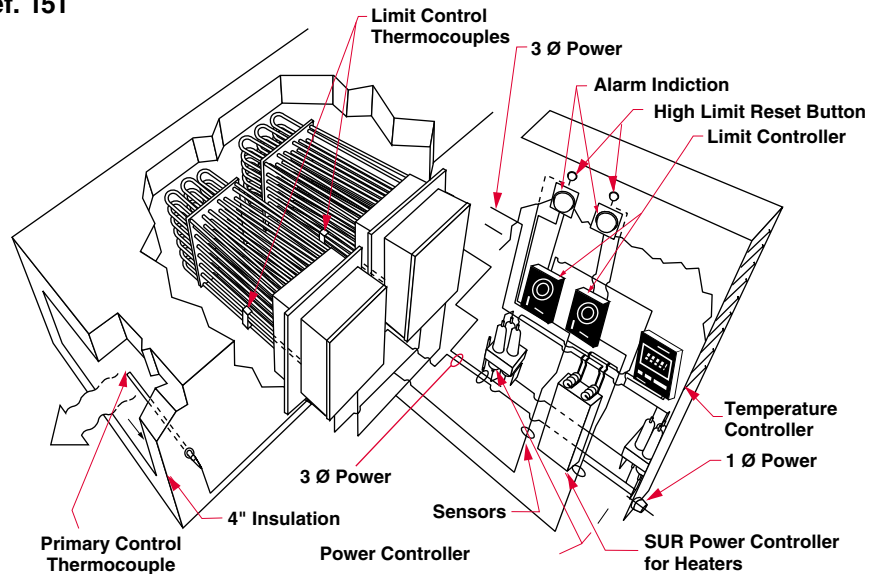

Step 1: Initial Heating Of Materials

Not required, because this application is a continuous air flow process.

$$Q_A = 0$$

Step 2: Heating of Air During Operation

From Equation 1, (Page 16)

$$\begin{aligned} Q_B &= \frac{w \cdot C_p \cdot \Delta T}{3.412} \\ &= \frac{(1825 \text{ lbs}) \cdot (0.245 \text{ Btu/lb} \cdot ^{\circ}\text{F}) \cdot (470^{\circ}\text{F})}{3.412 \text{ Btu/Wh}} \\ &= 61,591 \text{ Wh} \end{aligned}$$

where:

density of air at 560°F from Reference 137 (Page 143) = 0.039 lbs/ft^3

w = weight of air per hour

$$= \text{volume per min (CFM)} \cdot \frac{60 \text{ min}}{\text{hr}} \cdot \text{density (lbs/ft}^3)$$

$$= 780 \text{ CFM} \cdot \frac{60 \text{ min}}{\text{hr}} \cdot 0.039 \text{ lbs/ft}^3$$

$$= 1825 \text{ lbs/hr}$$

C_p = specific heat of air at 90°F = $0.24 \text{ Btu/lb} \cdot ^{\circ}\text{F}$, at 560°F = 0.25 ;
average = $0.245 \text{ Btu/lb} \cdot ^{\circ}\text{F}$

ΔT = temperature rise = $560^{\circ}\text{F} - 90^{\circ}\text{F} = 470^{\circ}\text{F}$

Application Guide

Reference Data

Examples of Applications

Continued

Step 3: Heat Required to Melt or Vaporize Materials During Initial Heating

Not required as the air does not change phase during heating.

$$Q_C = 0$$

Step 4: Heat Required to Melt or Vaporize Materials During Operating Cycle

Not required as the air does not change phase during heating.

$$Q_D = 0$$

Step 5: Determine Thermal System Heat Losses

Radiation and convection losses

From Equation 3D, (Page 18)

$$\begin{aligned} Q_{L4} &= A \cdot F_{SL} \cdot t_e \\ &= (74 \text{ ft}^2) \cdot (20 \text{ W/ft}^2) \cdot (1 \text{ hr}) \end{aligned}$$

$$Q_L = 1480 \text{ Wh}$$

where:

$$\begin{aligned} A &= \text{exposed surface area} \\ &= 12 \text{ ft} \cdot 2 \cdot \frac{(22 \text{ in.} + 15 \text{ in.})}{12 \text{ in./ft}} = 74 \text{ ft}^2 \end{aligned}$$

$$\begin{aligned} F_{SL} &= \text{surface loss factor at } \Delta T = 490^\circ\text{F} \text{ and 4 inch insulation} \\ &= 20 \text{ W/ft}^2 \text{ from Ref. 12 (Page 28)} \end{aligned}$$

$$t_e = \text{exposure time} = 1 \text{ hr}$$

Step 6: Calculate Start-up Power Requirements

Not required, because this application is a continuous air flow process.

$$P_S = 0$$

Step 7: Calculate Operating Power Requirements

From Equation 5, (Page 18) using a 10 percent safety factor,

$$\begin{aligned} \text{Operating Power} &= \left[\frac{Q_B + Q_D}{t_c} + \frac{Q_L}{t_e} \right] \cdot (1 + \text{S.F.}) \\ &= \left[\frac{61,591 \text{ Wh}}{1 \text{ hr}} + \frac{1480 \text{ Wh}}{1 \text{ hr}} \right] \cdot (1.1) \\ &= 69,378 \text{ watts} = 69.4 \text{ kW} \end{aligned}$$

where:

$$Q_B = 61,591 \text{ Wh}$$

$$Q_D = 0$$

$$Q_L = 1480 \text{ Wh}$$

$$t_c = 1 \text{ hour}$$

$$t_e = 1 \text{ hour}$$

$$\text{S.F.} = \text{safety factor} = 10\%$$

Application Guide

Reference Data

Examples of Applications

Continued

Air Duct Heater Power Evaluation

Ref. 152

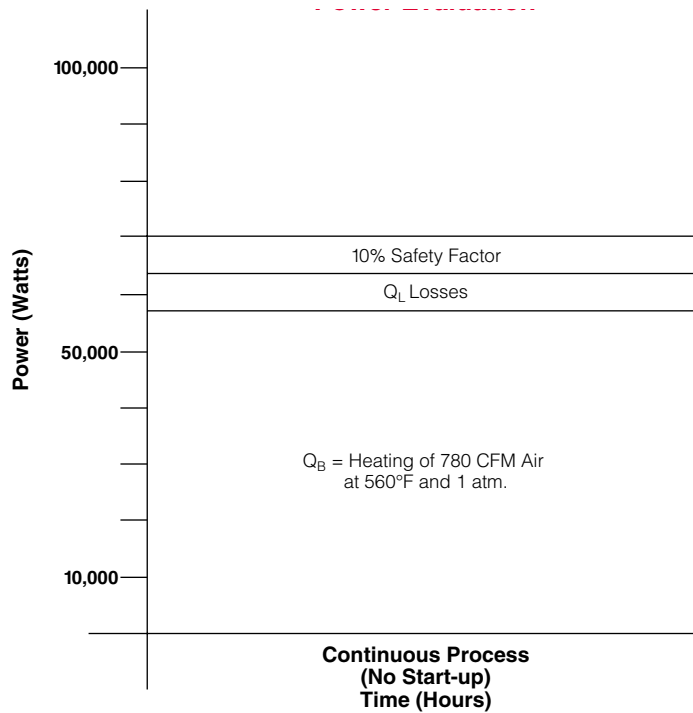

Heater Recommendations

The duct size of 15 inch X 22 inch is generally too small for a single 75 kilowatts unit. Therefore, two stock 36 kilowatts, 480 volt three phase units will be installed in series. Heating elements are tubular-type 0.430 inch diameter Incoloy® rated at 20 W/in².

Minimum air velocity of 180 ft/min must be maintained to provide sufficient heat transfer to prevent excessive element temperatures. The following are estimates of air velocity at the inlets of the two duct heaters to verify that the air velocity is sufficient.

While the mass flow rate through the duct is constant, the CFM and velocity are not, because they are determined by the air density which varies with temperature. As previously calculated the weight of air per hour = 1825 lbs/hr.

a. Air velocity v_1 at the inlet to duct heater # 1

$$v_1 = \frac{\text{volume per min. (CFM)}}{\text{duct area (ft}^2\text{)}} = \frac{422}{2.29} = 184 \text{ ft/min.}$$

where:

$$\begin{aligned} \text{CFM}_1 &= \frac{\text{weight of air per hour (lbs)}}{60 \text{ min/hr} \cdot \text{density (lbs/ft}^3\text{)}} \\ &= \frac{1825 \text{ lb/hr}}{60 \text{ min/hr} \cdot 0.072 \text{ lbs/ft}^3} = 422 \text{ CFM} \end{aligned}$$

density = 0.072 lbs/ft³ @ 90°F from Reference 137 (Page 143)

$$\text{duct area} = \frac{22 \text{ in.} \cdot 15 \text{ in.}}{144 \text{ in}^2/\text{ft}^2} = 2.29 \text{ ft}^2$$

Application Guide

Reference Data

Examples of Applications

Continued

b. Air velocity V_2 at the inlet to duct heater #2

$$v_2 = \frac{\text{volume per min (CFM)}}{\text{duct area (ft}^2\text{)}} = \frac{596}{2.29} = 260 \text{ ft/min}$$

where:

$$\text{CFM}_2 = \frac{\text{weight of air per hr (lbs)}}{60 \text{ min/hr} \cdot \text{density (lbs/ft}^3\text{)}}$$

$$= \frac{1825 \text{ lb/hr}}{60 \text{ min/hr} \cdot 0.051 \text{ lb/ft}^3} = 596 \text{ CFM}$$

The temperature at the inlet to duct heater #2 is the average of the heated and unheated air temperatures by assuming that each 36 kW heater supplies one-half of the heat:

$$T_2 = \frac{(560 + 90)}{2} = 325^\circ\text{F}$$

density = 0.051 lbs/ft³ @ 325°F from Reference 137 ([Page 143](#))

Control Requirements

Control accuracy in this application is not critical ($\pm 20^\circ\text{F}$), but digital indication is required. In addition, limit controllers with thermocouples must monitor the sheath temperature of each heater. The Watlow SERIES SD with Type J thermocouple input is the correct controller choice. A Watlow

limit controller is recommended, providing two channels of high limit control with Type J thermocouple inputs from the heaters. Each heater will be delta connected across the 480 volt, three-phase line and switched by a SCR power switching device for long, dependable service and heater life.

Application Guide

Reference Data

Examples of Applications

Continued

Objective

A manufacturing process requires that 24 inch x 24 inch x 0.031 inch pieces of 304 stainless steel be heated to 300°F in one minute. The stainless steel has a coating with an emissivity of 0.80. A radiant panel can be located two inches above the metal.

Drying a Moving Web of Cloth

1. Collect the data, make assumptions. To uniformly heat the product, choose a heater size that overlaps an amount equal to the distance between the heater and the sheet of steel, i.e.:

Heater Size = 28 in. • 28 in.

- $\Delta T = 300 - 60 = 240^\circ\text{F}$
- Weight/in² = 500 lbs/ft³ • 1 ft³/1728 in² • 0.031 in. thick = 0.00897 lbs/in²*
- Specific heat = 0.12 Btu/lb°F*
- Time = 1 minute = 0.0167 hrs
- Emissivity of product = $E_p = 0.080$

2. Determine the wattage required to heat one square inch of the material.

$$\text{Watts} = \frac{w \cdot \text{specific heat} \cdot \Delta T}{\text{Time} \cdot 3.412 \text{ Btu/Wh}}$$

$$\text{Watts} = \frac{0.00897 \text{ lbs/in}^2 \cdot 0.12 \text{ Btu/lb}^\circ\text{F} \cdot 240^\circ\text{F}}{0.0167 \text{ hrs.} \cdot 3.412 \text{ Btu/Wh}}$$

$$\text{Watts} = 4.54 \text{ W/in}^2$$

3. Using the radiant heat transfer equation, determine the radiant heater temperature needed to transfer the required wattage found above.

$$\text{W/in}^2 = \frac{S(\text{Th}^4 - \text{Tp}^4) \cdot E \cdot F}{144 \text{ in}^2/\text{ft}^2 \cdot 3.412 \text{ Btu/Wh}}$$

- A. Compute the view factor F

The heater is 28 in. • 28 in., located two inches from the product.

$$M = \frac{28}{2} = 14 \quad N = \frac{28}{2} = 14$$

$$F = 0.85$$

- B. Compute the effective emissivity (E).

Emissivity of heater = $E_h = 0.85$

$$E = \frac{1}{\frac{1}{E_h} + \frac{1 - E_p}{E_p}} = \frac{1}{\frac{1}{0.85} + \frac{1 - 0.8}{0.8}} = 0.70$$

- C. Determine the average product temperature (Tp)

$$\text{Tp} = \frac{300 + 60}{2} = 180^\circ\text{F} = 640^\circ\text{R}$$

Application Guide

Reference Data

Examples of Applications

Continued

D. Plug into the radiant heat transfer equation

$$W/in^2 = \frac{S(Th^4 - Tp^4) \cdot E \cdot F}{144 \text{ in}^2/\text{ft}^2 \cdot 3.412 \text{ Btu/Wh}}$$

From above we found:

$$E = 0.70$$

$$F = 0.85$$

$$Tp = 640^\circ\text{R}$$

$$\text{Required } W/in^2 = 4.54$$

Therefore:

$$4.54 \text{ W/in}^2 = \frac{S(Th^4 - (640)^4) \cdot 0.7 \cdot 0.85}{144 \text{ in}^2/\text{ft}^2 \cdot 3.412 \text{ Btu/Wh}}$$

$$7.6 \text{ W/in}^2 = \frac{S(Th^4 - (640)^4)}{144 \text{ in}^2/\text{ft}^2 \cdot 3.412 \text{ Btu/Wh}}$$

$$S = 0.1714 \cdot 10^{-8} \text{ Btu/hr ft}^2\text{R}^4$$

E. Determine the required heater temperature (Th)

All information required to solve the above equation for the heater temperature (Th) is now available. Note that the equation gives Th in °R.

$$Th (^\circ\text{F}) = Th (^\circ\text{R}) - 460$$

From the graph or the calculation, find:

$$Th = 780^\circ\text{F}$$

To transfer the required watts, the heater must operate at 780°F.

Comments/Questions

What is the required heater watt density?

If selecting a Watlow RAYMAX® 1120 for this application, this heater requires about 9 W/in² to maintain 780°F face temperature in open air. In this application, slightly less would be required since some of the radiant energy that is reflected off of the 0.80 emissivity surface of the metal is reflected back into the heater and re-absorbed. This would be a much more significant factor if the product surface had a lower emissivity, say 0.5.

What about losses off the surface of the metal as it heats up?

Generally, the air temperature between the heater and the product is higher than the product temperature, so some convection heating takes place. In this application, assume the plate is resting on a good heat insulator and there is very little air movement. If this is not the case, then these losses must be estimated and added to the required wattage determined above.

Glossary

Definitions of Commonly Used Terms Used in Heating, Sensing and Controlling

Introduction

The terms contained in this glossary are defined according to their most common use as they apply to heaters, temperature sensors, temperature controllers and power controllers. Also included are terms used in the general discussion of thermodynamic theory, thermal systems and heat energy.

A

A.G.A. See “American Gas Association.”

abrasion resistance The ability of a material to resist mechanical wear.

absolute zero The temperature at which substances possess minimal energy. Absolute zero is 0 Kelvin or 0° Rankine and is estimated to be -273.15°C (-459.67°F).

ac (~) See alternating current.

ac line frequency The frequency of the alternating current power line measured in Hertz (Hz), usually 50 or 60Hz.

ac/dc (≐) Both direct and alternating current.

accelerated aging A test that simulates the effects of long-term environmental and operating conditions in a relatively short time period.

accuracy Difference between the value indicated by a measuring instrument and the corresponding true value. Sensor accuracy is based on US NIST (NBS) standards.

action The response of an output when the process variable is changed. See also “direct action,” and “reverse action.”

active components An electronic device whose properties change with a change in the applied signal. Diodes, transistors and integrated circuits are active components.

actual The present value of the controlled variable.

address An identification, represented by a name, label or number, of a register or location in storage, or any other data source or destination, such as the location of a station in a communication network.

Advance® A thermocouple alloy made of 55 percent copper and 45 percent nickel, used as the negative conductor in ASTM Type E, J, and T thermocouples. Advance® is a registered trademark of Harrison Alloys Company.

alarm A signal that indicates that the process has exceeded or fallen below the set or limit point. For example, an alarm may indicate that a process is too hot or too cold.

alarm dead band An area of no control or alarm change.

alarm delay The lag time before an alarm is activated.

alarm hysteresis A change in the process variable required to re-energize the alarm output.

alarm module 1) A controller hardware and software combination configured to alert an operator or perform another function in response to a problem in the thermal system. 2) A specific behavioral feature in the NAFEM (National Association of Food Equipment Manufacturers) data protocol model that determines if an alarm condition exists. It does this by providing criteria to compare against alarm object attributes.

alarm silence A feature that disables the alarm relay output.

Alloy #11® A compensating alloy made of 99 percent copper and one percent nickel. It is used to make the negative conductor that, in conjunction with pure copper, forms thermocouple extension wire for ASTM Type R and S thermocouples (platinum, platinum/rhodium). Alloy #11® is a registered trademark of Harrison Alloys. See “compensating alloy.”

Alloy 188® A cobalt-based austenitic alloy that exhibits high strength and resistance to oxidation and corrosion. It is commonly used in the aerospace, nuclear, chemical and process industries. Alloy 188® is a registered trademark of Haynes International.

Alloy 203/225 Alloys made up of 90 percent nickel and 10 percent chromium (203), and 98 percent nickel and two percent chromium (225). They form thermocouple extension wire conductors for Type D (W3Re/W25Re) thermocouples for applications under 200°C (400°F). Type D is not an ASTM calibration.

Alloy 214® A material that exhibits excellent resistance to oxidation, carburization and chlorine-bearing atmospheres. It is commonly used to make sensor probe sheaths. Alloy 214® is a registered trademark of Haynes International.

Alloy 230® A material that exhibits excellent high temperature strength, oxidation resistance and long-term thermal stability. It works well in nitriding environments, and is commonly used to make sensor probe sheaths. Alloy 230® is a registered trademark of Haynes International.

Glossary

Alloy 405/426 Alloys made of 94.5 percent nickel, two percent manganese, one percent silicon and 1.5 percent aluminum (405), and 80 percent nickel and 20 percent copper (426). They form thermocouple extension wire conductors for use with Type C (W5Re/W26Re) thermocouples for applications under 870°C (1600°F). Type C is not an ASTM calibration.

Alloy 556® A multipurpose alloy that exhibits good resistance to sulfidizing, carburizing and chlorine-bearing environments. Alloy 556® is a registered trademark of Haynes International.

Alloy HR160® A material that exhibits superior resistance to sulfides with good resistance in some salt bath applications. It is commonly used to make sensor probe sheaths. Alloy HR160® is a registered trademark of Haynes International.

alpha (A) The temperature coefficient of the change in electrical resistance of a material measured in ohms/ohm/°C. It indicates the basic change in electrical resistance in a material for each °C in temperature. Alpha is a defining parameter for resistance temperature detectors (RTDs). For example, common alphas for platinum RTDs are 0.00385 $\Omega/\Omega/^\circ\text{C}$ (DIN) or 0.003916 $\Omega/\Omega/^\circ\text{C}$ (JIS).

alternating current (~) An electric current that reverses at regular intervals, and alternates positive and negative values.

Alumel® An alloy made of 95 percent nickel, two percent aluminum, two percent manganese and one percent silicon. It forms the negative conductor of ASTM Type K thermocouples. Alumel® is a registered trademark of the Hoskins Manufacturing Company.

ambient compensation See “compensation, ambient.”

ambient temperature See “temperature, ambient.”

American Gas Association (A.G.A.) Independent testing laboratory that tests gas-related appliances and accessories to ANSI standards, or to A.G.A. standards in the absence of a nationally-recognized standard. Watlow now uses nationally recognized testing laboratories to ANSI standards for gas-related products, rather than A.G.A.

American Wire Gauge (AWG) A standard of the dimensional characteristics of wire used to conduct electrical current or signals. AWG is identical to the Brown and Sharpe (B & S) wire gauge.

ammeter An instrument that measures the magnitude of an electric current.

ampere (amp, A) A unit that defines the rate of flow of electricity (current) in a circuit. Units are one coulomb (6.25 x 1,018 electrons) per second.

analog A method of representing data using the amplitude of a signal.

analog output A continuously variable signal that is used to represent a value, such as the process value or set point value. Typical hardware configurations are 0 to 20mA, 4 to 20mA or 0 to 5V $\overline{=}$ (dc).

anneal To relieve stress in a solid material by heating it to just below its melting point and then gradually cooling it to ambient temperature. Annealing usually lowers the tensile strength while improving flexibility and flex life. Metals and glasses are commonly annealed.

annunciator A visual display that uses indicator lights to display the former or existing condition of several items in a system.

ANSI American National Standards Institute. The United States government agency that defines and maintains technical standards.

anti-reset See “anti-reset windup.”

anti-reset windup The feature of a PID temperature controller that prevents the integral (automatic reset) circuit from functioning when the temperature is outside the proportional band. This standard feature helps stabilize a system. Also called “anti-reset.”

Application layer (OSI Layer 7) The highest layer of the seven-layer OSI (Open System Interconnection) model where communication begins with a specific application that communicates with another device or system. All application-specific functions occur here, such as user authentication and addressing. An e-mail application or web browser are examples of the application layer for exchanging data over the Internet. The Application Layer resides above the Presentation Layer.

ARP (Address Resolution Protocol) The TCP/IP protocol that converts an IP address into a physical hardware address, such as an address for an address for an Ethernet card.

ASME American Society of Mechanical Engineers.

ASTM American Society for Testing and Materials.

atmosphere The ambient environment.

atmosphere (atm) A standard unit of pressure representing the pressure exerted by a 760 mm (29.92 in.) column of mercury at sea level at 45 degrees latitude and equal to 1,000 g/cm² (14.22 psi).

atmospheric pressure Pressure in grams per square centimeter or pounds per square inch exerted by the earth’s atmosphere on bodies located within it.

Glossary

atmospheric pressure, standard

Pressure exerted by the earth's atmosphere on bodies located within it. Standard atmospheric pressure is 14.7 psi (1.013 bar abs.) measured at sea level and 15°C (60°F).

automatic mode A feature that allows the controller to set PID control outputs in response to the process variable (PV) and the set point.

automatic power reset A feature in latching limit controllers that does not recognize power outage as a limit condition. When power is restored, the output is re-energized automatically, as long as the temperature is within limits.

automatic prompts Data entry points where a microprocessor-based controller asks the operator to enter a control value.

automatic reset The integral function of a PI or PID temperature controller that adjusts the process temperature to the set point after the system stabilizes. The inverse of integral.

auto-tune A feature that automatically sets temperature control PID values to match a particular thermal system.

auxiliary output An output that controls external activities that are not directly related to the primary control output. For example, door latches, gas purges, lights and buzzers.

AWG See "American Wire Gauge."

B

B & S Gauge (Brown and Sharp Gauge) A standard of the dimensional characteristics of wire used to conduct electrical current or signals. It is identical to the American Wire Gauge.

B.T.E. thermocouple holes "Behind-the-element" ceramic tubes create electrically isolated thermocouple holes through Watlow ceramic fiber heaters. The holes are built into the heaters to very closely track element temperature for over-temperature protection and to improve heater life.

bandwidth A symmetrical region above and below the set point in which proportional control occurs.

base metal thermocouple Thermocouples with conductors made of base metallic element alloys (iron, copper, and nickel). Base metal thermocouples are ASTM Types E, J, K, N and T. They are usually used in lower temperature applications.

baud rate The rate of information transfer in serial communications, measured in bits per second.

BCC See "Block Check Character."

bend radius (standard) The specified minimum radius to which a sensor (or wire) can be bent without stressing the structure of the metal or damaging its electrical transmitting characteristics. Standard bend radius is a function of sensor (or wire) diameter.

beryllia/beryllium oxide (BeO) A white crystalline powder with a high melting temperature (approximately 2585°C or 4685°F, high thermal conductivity and high dielectric strength. Used in high-temperature ceramic thermocouple insulation. Its dust and particles are toxic. Special precautions are required when handling BeO.

blackbody An ideal surface that absorbs all incident radiation, regardless of wavelength, the direction of incidence and polarization. It radiates the maximum energy possible for given spectral and temperature conditions. A blackbody has an emissivity of 1.00. See "emissivity."

block A set of things, such as words, characters or digits that are handled as a unit.

Block Check Character (BCC) A serial communications error checking method. An acceptable method for most applications, BCC is the default method. See "Cyclic Redundancy Check (CRC)."

blocking voltage The maximum voltage a surge protector can accept without degrading its component current-protective devices.

boiling point The equilibrium temperature between a liquid and a gaseous state. For example, the boiling point of water is 100°C (212°F) at standard atmospheric pressure.

bonding The process of joining two similar or dissimilar materials. In temperature sensors and lead wires, bonding usually establishes a seal against moisture. See "potting."

braid A flexible covering formed from plaited (served) textile or ceramic fibers or metallic filaments. Textile and ceramic fibers are used to produce electrical insulation around electrical conductors. Metallic filaments are used to add abrasion resistance or shielding from electrical noise.

bright annealing The description of stainless steel or aluminum after final surface treatment, produced by passing the metal between rollers with a moderately smooth surface. This surface treatment is used in the processing of aluminum sheets, stainless steel back plates, stainless steel cold rolled sheets and cold rolled strip steels.

browser A software application that finds and displays web pages. Also called "web browser."

BS British Standards. The United Kingdom agency that defines and maintains technical standards.

Glossary

Btu British Thermal Unit. A unit of energy defined as the amount of heat required to raise one pound of water from 32°F to 33°F at standard atmospheric pressure. One Btu is equal to 0.293 watt-hours. One kilowatt-hour is equal to 3,412 Btus.

bumpless transfer A smooth transition from auto (closed loop) to manual (open loop) operation. The control output(s) does (do) not change during the transfer.

burst fire A power control method that repeatedly turns on and off full ac cycles. Also called zero-cross fire, it switches close to the zero-voltage point of the ac sine wave to minimize radio frequency interference (RFI). Variable time-base burst fire selectively holds or transits ac cycles to achieve the desired power level.

bushing The process of adding additional sheath tubing to achieve a larger, non-standard diameter.

C

cabling Gathering insulated electrical conductors into a single cable. Methods include serving (braiding), extruding or wrapping.

Calendar van Dusen equation An interpolation equation that provides resistance values as a function of temperature for RTDs.

calibration The comparison of a measuring device (an unknown) against an equal or better standard.

calibration accuracy Difference between the value indicated by a measuring instrument and a physical constant or known standard.

calibration offset An adjustment to eliminate the difference between the indicated value and the actual process value.

calorie A unit of energy defined as the amount of heat energy required to raise the temperature of one gram of water 1°C at 15°C.

carbon potential control The ability to control the carbon content in steel inside heat treating furnaces.

cascade Control algorithm in which the output of one control loop provides the set point for another loop. The second loop, in turn, determines the control action.

CAT.5 Category 5 wiring or cable manufactured to the TIA/EIA 568-A standard. The standard Ethernet wiring for 10 Mbps or 100 Mbps networks in four twisted pairs; insulated, unshielded and jacketed cable. Terminated with RJ45 connectors in lengths of 100m or less.

CDA Confidential Disclosure Agreement. A legal document that spells out the conditions and circumstances by which confidential information can be shared with another party, and the remedies required for violations. Companies typically use both general CDAs and detailed CDAs that cite specific intellectual property to protect. See “MCDA.”

CE A manufacturer’s mark that demonstrates compliance with European Union (EU) laws governing products sold in Europe.

CE-compliant Compliant with the essential requirements of European directives pertaining to safety and/or electromagnetic compatibility.

Celsius (C) Formerly known as Centigrade. A temperature scale in which water freezes at 0°C and boils at 100°C at standard atmospheric pressure. The formula for conversion to the Fahrenheit scale is:
°F = (1.8 × °C) + 32.

central processing unit (CPU) The unit of a computing system that includes the circuits controlling the interpretation of instructions and their execution.

ceramic fiber An alumina-silica fiber that is lightweight and low density. It is used as a refractory material.

ceramic insulation Materials made of metal oxides that are capable of withstanding high temperatures and providing the desired dielectric strength. They are used to insulate heater elements or thermocouple wires.

CFD Computational Fluid Dynamics. Numerical technique to solve and simulate the behavior of the Navier-Stokes equation that describes fluid flow. Used by Watlow for thermal system simulation.

cfm Cubic feet per minute. The volumetric flow rate of a fluid. When used in gas flow, it is evaluated at a given process temperature and pressure.

channel See “control channel.”

chatter The rapid on-off cycling of an electromechanical relay or mercury displacement relay due to insufficient controller bandwidth. It is commonly caused by excessive gain, little hysteresis and short cycle time.

chemical resistance The ability of a material to resist permeation, erosion or corrosion caused by base, acid or solvent chemicals.

Chromel® An alloy made of approximately 90 percent nickel and 10 percent chromium that is used to make the positive conductors of ASTM Type E and K thermocouples. Chromel® is a registered trademark of the Hoskins Manufacturing Company.

circuit Any closed path for electrical current. A configuration of electrically or electromagnetically-connected components or devices.

client The client half of a client-server system where the client is typically an application (residing on a personal computer) that makes requests to a server, computer with one or more clients networked to it. E-mail is an example of a client-server system.

Glossary

closed loop A control system that uses a sensor to measure a process variable and makes decisions based on that input.

CMM 1) Cubic meters per minute, a measure of airflow. 2) Coordinate Measuring Machines, used for dimensional inspection in manufacturing and quality applications. 3) Capability Maturity Model®, a registered trademark software development management model of the Software Engineering Institute (SEI), a research and development center sponsored by the U.S. Department of Defense and operated by Carnegie Mellon University.

CNC Computerized Numerical Control. The programmed instructions used by a class of cutting tool machines (usually driven by design software) for creating machined parts and molds.

coaxial cable A cylindrical transmission cable made of an insulated conductor or conductors centered inside a metallic tube or shield, typically of braided wires. It isolates the signal-carrying conductor from electrical interference or noise.

cold junction Connection point between thermocouple metals and the electronic instrument. See “reference junction.”

cold junction compensation

Electronic means to compensate for the effective temperature at the cold junction.

color code A system of standard colors used to identify electrical conductors. For example, a color code identifies the thermocouple type in thermocouple circuits. Codes common in the United States have ASTM designations. Color codes vary in different countries.

common-mode line filter A device to filter noise signals on both power lines with respect to ground.

common-mode rejection ratio The ability of an instrument to reject electrical noise, with relation to ground, from a common voltage. Usually expressed in decibels (dB).

communications The use of digital computer messages to link components. See “serial communications” and “baud rate.”

compensated connectors A thermocouple connector that uses either actual thermocouple alloy contacts or compensating alloy contacts. Maintaining metallic circuit properties throughout the connection circuit reduces errors due to mismatched materials.

compensating alloy Any alloy that has similar resistance to another thermocouple alloy. Compensating alloys are usually low cost alternatives for extension lead wire types. For example, Alloy #11 is a compensating lead wire for platinum thermocouple sensors.

compensating loop An extra pair of lead wires that have the same resistance as the actual lead wires, but are not connected to the RTD element. A compensating loop corrects lead wire resistance errors when measuring temperature.

compensated, ambient The ability of an instrument to adjust for changes in the temperature of the environment and correct the readings. Sensors are most accurate when maintained at a constant ambient temperature. When temperature changes, output drifts.

computer ground A line for the ground connections to computers or microprocessor-based systems. It is isolated from the safety ground.

conduction The mode of heat transfer within a body or between bodies in contact, caused by the junction between adjacent molecules.

conductivity Electrical conductivity is the ability of a conductor to allow the passage of electrons, measured in the current per unit of voltage applied. It is the reciprocal of resistivity. Thermal conductivity is the quantity of heat conducted through a body per unit area, per unit time, per unit thickness for a temperature difference of 1 kelvin.

connection head A housing on a sensor assembly. It provides a terminal block for electrical connections, and allows the attachment of protection tubes and cables or conduit hook-ups.

connectivity Computer jargon that describes the readiness or capability of a device for communicating with other devices or systems.

Constantan A generic designation for a thermocouple alloy made of 55 percent copper and 45 percent nickel that is used as the negative conductor in ASTM Type E, J and T thermocouples.

continuity check A test of finished assemblies or wire that indicates whether electric current flows continuously throughout the length of the material. It also shows a short circuit between conductors.

control accuracy The ability to maintain a process at the desired setting. This is a function of the entire system, including sensors, controllers, heaters, loads and inefficiencies.

control action The response of the control output relative to the difference between the process variable and the set point. For reverse action (usually heating), as the process decreases below the set point, the output increases. For direct action (usually cooling), as the process increases above the set point, the output increases.

Glossary

control channel Often synonymous with “control loop.” In some markets, such as life sciences, its use may indicate the presence of a data communications feature.

control loop A control system with feedback (closed loop) from a single load to the controller, or without feedback (open loop) from the load to the controller.

control mode The type of action that a controller uses. For example, on-off, time proportioning, PID, automatic or manual, and combinations of these.

controllability See “accuracy” and “control.”

convection A mode of heat transfer in a fluid (gas or liquid) in which heat is transferred through movement of masses of the fluid from a region of higher temperature to one of lower temperature.

copper The positive conductor in an ASTM Type T thermocouple. See “OFHC.”

cps Cycles per second. Frequency. Also referred to as Hertz.

CRC See “Cyclic Redundancy Check.”

crosstalk Audio frequency signal interference coupled from one signal-carrying conductor to an adjacent conductor.

cryogenic Related to low temperatures. Generally in the range of 0° to -200°C (32° to -328°F).

CSA Canadian Standards Association. An independent testing laboratory that establishes commercial and industrial standards, tests and certifies products.

C-UL® Canadian recognition of Underwriters Laboratories, Inc. (UL®) approval of a particular product class, such as UL® 508. In some instances, C-UL® approval may stand in lieu of Canadian Standards Association (CSA) approval. All references to C-UL® stem from the original UL® file only, resident at the location of UL® approval. See “CSA and “UL®”.

Cupron® A thermocouple alloy made of 55 percent copper and 45 percent nickel. It is used in the negative conductor of ASTM Type E, J and T thermocouples. Cupron® is a registered trademark of Carpenter Technology.

current The rate of flow of electricity. The unit of measure is the ampere (A). 1 ampere = 1 coulomb per second.

current transformer A transformer designed for measuring electrical current.

cycle time The time required for a controller to complete one on-off-on cycle. It is usually expressed in seconds.

Cyclic Redundancy Check (CRC) An error checking method in communications. It provides a high level of data security, but is more difficult to implement than Block Check Character (BCC). See “Block Check Character.”

D

Data Link Layer (OSI Layer 2) The second layer of the seven-layer OSI (Open System Interconnection) protocol model that handles data packet encoding and decoding to and from bits on a network. The Data Link Layer has two sublayers, Media Access Control (MAC), and Logical Link Control (LLC). The Data Link Layer resides between the Transport Layer and the Physical Layer.

data logging A method of recording a process variable over a period of time. Used to review process performance.

dc (≡) Direct current. An electrical current that flows in one direction.

dc resistance See “resistance.”

dead band The range through which a variation of the input produces no noticeable change in the output. In the deadband, specific conditions can be placed on control output actions.

decalibration An output shift in the thermocouple so that it no longer conforms to established standards. The shift is caused by the altering of alloys in the thermocouple conductors.

default parameters The programmed values that are permanently stored in the microprocessor software.

degree The increments in a temperature scale, or the increments of rotation of a dial. The location of a reference point in electric or phase in a cycle, in mechanical or electrical cyclic scales. One cycle is equal to 360 degrees.

density Mass per unit volume of a substance expressed in kilograms per cubic meter or pounds per cubic foot

derivative The rate of change in a process variable. Also known as rate. See “PID.”

derivative control (D) The last term in the PID control algorithm. Action that anticipates the rate of change of the process variable and compensates to minimize overshoot and undershoot. Derivative control is an instantaneous change of the control output in the same direction as the proportional error. This is caused by a change in the process variable (PV) that decreases over the time of the derivative (TD). The TD is in units of seconds.

Glossary

Deutsche Industrial Norm (DIN) A set of technical, scientific and dimensional standards developed in Germany. Many DIN standards have worldwide recognition.

deviation Any departure from a desired value or expected value or pattern. Sometimes referred to as delta.

deviation alarm Warns when a process exceeds or falls below a certain range from the set point. Alarms can be referenced at a fixed number of degrees, plus or minus, the set point.

DHCP Dynamic Host Configuration Protocol. A protocol that assigns a network device, a unique IP address each time it logs onto a network.

di/dt The time rate of change in current. Excessive di/dt can damage a phase-fired silicon controlled rectifier (SCR) power controller when it is used for large resistive loads. In this case, an inductor may be necessary to protect the SCR.

dielectric An insulating material with very low electrical conductivity.

dielectric breakdown The point at which a dielectric substance becomes conductive. Usually a catastrophic insulation failure caused by excessive voltage.

dielectric strength The potential gradient at which electric failure or breakdown occurs. Also known as breakdown potential.

differential control A control algorithm where the set point represents a desired difference between two processes. The controller then manipulates the second process to hold it at a set value relative to the first controller.

differential mode line filter A device to filter electrical noise between two power lines.

diffusion A gradual mixing of molecules of two or more substances through random thermal motion.

digital adaptive filter A filter that rejects high frequency input signal noise (noise spikes).

digital filter (DF) A filter that slows the response of a system when inputs change unrealistically or too fast. Equivalent to a standard resistor-capacitor (RC) filter.

DIN See "Deutsche Industrial Norm."

direct action An output control action in which an increase in the process variable causes an increase in the output. Cooling applications usually use direct action.

direct current (DC) An electric current that flows in one direction.

display capability In an instrument with digital display, the entire possible span of a particular parameter or value.

dissipation constant The ratio of the change in internal power dissipation to the resulting change in the body temperature of a thermistor.

distributed zero crossing (DZC) A form of digital output control used by Watlow Anafaze in which the output on-off state is calculated for every cycle of the ac line cycle. Power is switched at the zero crossing point, reducing electrical noise. See "zero cross."

distributed zero crossing (DZC) A form of digital output control. Similar to burst fire.

DNS Domain Name Server. A computer that translates alphabetic internet domain names into IP (Internet protocol) addresses.

drain wire An uninsulated wire that is used as a ground conductor in wire and cable construction.

draw A manufacturing process action that pulls a material through a die to compact the material.

drift A change in reading or value that occurs over long periods. Changes in ambient temperature, component aging, contamination, humidity and line voltage may contribute to drift.

droop In proportional controllers, the difference between set point and actual value after the system stabilizes. The integral (reset) component of PID control corrects droop.

dual element sensor A sensor with two independent sensing elements. Usually used to measure temperature gradients or provide redundancy in a single point sensor assembly.

duplex control With enhanced software, duplex control splits a single process output into two individual outputs. For example, a 4 to 20mA output is split into a 4 to 12mA direct action (cooling) output and a 12 to 20mA reverse action (heating) output, thus allowing one control output to function as two.

duplex wire A cable or wire with two insulated conductors that are parallel or twisted together. Duplex constructions may also include a drain-wire conductor.

duty cycle The percentage of a cycle time in which the output is on.

dv/dt Time rate of change in voltage. Excess dv/dt can cause false turn on and destroy a silicon controlled rectifier (SCR) power controller. Loose wiring connections may arc and produce this voltage change.

E

earth ground A metal rod, usually copper, that provides an electrical path to the earth, to prevent or reduce the risk of electric shock.

Glossary

efficiency The ratio of useful output energy (work) to input energy.

EIA See “Electronics Industries of America.”

EIA/TIA -232, -422, -423 and -485

Data communications standards set by the Electronic Industries of America and Telecommunications Industry Association. Formerly referred to as RS (Recognized Standard).

EIA/TIA-232 (formerly RS-232) An Electronics Industries of America (EIA)/Telecommunication Industry Association (TIA) standard for interface between data terminal equipment and data communications equipment for serial binary data interchange. This is usually for communications over a short distance (50 feet or less) and to a single device.

EIA/TIA-485 (formerly RS-485) An Electronics Industries of America (EIA)/Telecommunication Industry Association (TIA) standard for electrical characteristics of generators and receivers for use in balanced digital multipoint systems. This is usually used to communicate with multiple devices over a common cable or where distances over 50 feet are required.

elastomer Any material that returns to its original shape or dimensions after being stretched or distorted.

electrical interference Electrical noise that can obscure desired information.

electrical noise See “noise.”

electrical-mechanical relay See “relay” and “electromechanical relay.”

electromagnetic compatibility (EMC) The ability of equipment or a system to function as designed in its electromagnetic environment without introducing intolerable electromagnetic disturbances to that environment, or being affected by electromagnetic disturbances in it.

electromagnetic interference (EMI) Electrical and magnetic noise imposed on a system. There are many possible causes, such as switching ac power on inside the sine wave. EMI can interfere with the operation of controls and other devices.

electromechanical relay A power switching device that completes or interrupts a circuit by physically opening or closing electrical contacts. Not recommended for PID control.

electromotive force (EMF) A difference in electrical potential energy, measured in volts.

Electronics Industries of America (EIA) An association in the US that establishes standards for electronics and data communications.

electropolishing Creating a bright, smooth metal surface by depositing a thin layer of another metal on it via electrolysis. Also, “electroplating.”

electrostatic discharge (ESD) An electrical discharge, usually of high voltage and low current. For example, the shock that occurs when walking across a carpet.

EMC See “electromagnetic compatibility.”

EMF See “electromotive force.”

EMI See “electromagnetic interference.”

emissivity The ratio of radiation emitted from a surface compared to radiation emitted from a blackbody at the same temperature.

endothermic A process that absorbs heat.

engineering units Selectable units of measure, such as degrees Celsius and Fahrenheit, pounds per square inch, newtons per meter, gallons per minute, liters per minute, cubic feet per minute or cubic meters per minute.

enthalpy A property expressing the relative energy state of a gas or vapor at a given temperature, pressure and volume. Expressed in units of Btu/lb or Joules/gram. It is used to evaluate the energy change that occurs when a vapor or gas is heated. Steam heating problems are readily solved using this property.

EPROM Erasable, programmable, read-only memory inside the controller.

error The difference between the correct or desired value and the actual measured value.

ESD See “electrostatic discharge.”

e-Solutions A system that allows Watlow’s Authorized Distributors to complete business transactions with Watlow via the Internet. **e-Solutions** allows Watlow’s Distributors to order products, to build products to meet specifications, to check order status and stock availability, and to access a variety of other features.

ETFE Ethylene tetrafluoroethylene, or Tefzel®, the DuPont brand. See “Tefzel.”

Ethernet A local area network (LAN) protocol that supports a bus or star-configured network with speeds up to 1,000 Mbps (megabits per second).

event An input or output signal representing an on or off state. Events can control peripheral equipment or processes, or act as an input for another control or control loop.

exothermic A process that releases heat.

explosion-proof enclosure An enclosure designed to withstand an explosion of gases inside, to isolate sparks inside from explosive or flammable substance outside, and to maintain an external temperature that will not ignite surrounding flammable gases or liquids.

Glossary

exposed junction A type of thermocouple probe in which the hot, or measuring, junction protrudes beyond the sheath material and is fully exposed to the substance being measured. It usually gives the fastest response time. No electrical isolation is provided.

extension wire See “thermocouple extension wire.”

external transmitter power supply A dc voltage source that powers external devices.

extrusion A process by which a material is melted and pushed or pulled through a die to create a desired shape.

F

Fahrenheit The temperature scale that sets the freezing point of water at 32°F and its boiling point at 212°F at standard atmospheric pressure. The formula for conversion to Celsius is: $^{\circ}\text{C} = \frac{5}{9} (^{\circ}\text{F} - 32^{\circ}\text{F})$.

failed sensor alarm Warns that an input sensor no longer produces a valid signal. For example, when there are thermocouple breaks, infrared problems, or resistance temperature detector (RTD) open or short failures.

FEA Finite Element Analysis. A Watlow Research and Development method of using a computer simulation to create a thermal model of a heater or heated part, saving the time and expense of multiple prototype builds. FEA optimizes the heater design with an accurate prediction of the expected temperature uniformity.

FEM Finite Element Method. A numerical technique to solve and simulate the behavior of differential equations, used for thermal system simulation.

FEP Fluorinated ethylene propylene. A fluorocarbon copolymer of tetrafluoroethylene and hexafluoropropylene. See “Teflon®.”

ferrule A tubular compression component used to mount a temperature sensing probe. It creates a gas-tight seal.

fiber, insulation Any nonmetallic, nonconductive textile that is used to insulate conductors. Fibers may be braided or wrapped.

field of view The target size or distance necessary for an infrared sensor to receive 90 percent of the power radiated by a surface.

FIREROD® A registered tradename for Watlow’s patented cartridge heater.

firmware A combination of software and hardware, where the software is written (embedded) into a ROM (read only memory) chip, such as PROM (programmable read only memory) or EPROM (erasable programmable read only memory).

fixed point A reproducible temperature at the equilibrium point between the phase changes in a material. For example, the triple point of water at standard atmospheric pressure is 0.01°C (32.02°F).

flexibility The relative ease with which a conductor can bend. See “bend radius.”

flow area The unobstructed area in the cross section of a conduit that is available for fluid flow.

flow rate The actual volume of a fluid passing through a section of a conduit. Flow rate may be measured in cubic feet per minute, cubic meters per second or other units.

FM See “Factory Mutual Research Corporation.”

FNPT informal; Female (internal) National Pipe Thread.

Form A — A single-pole, single-throw relay that uses only the normally open (NO) and common contacts. These contacts close when the relay coil is energized. They open when power is removed from the coil.

Form A or C — An electromechanical relay capable of Form A or Form C function, selected with a jumper wire.

Form B — A single-pole, single-throw relay that uses only the normally closed (NC) and common contacts. These contacts open when the relay coil is energized. They close when power is removed from the coil.

Form C — A single-pole, double-throw relay that uses the normally open (NO), normally closed (NC) and common contacts. The operator can choose to wire for a Form A or Form B contact.

fpm Feet per minute. A measure of flow velocity. When used in gas flow, it is evaluated at a specific process temperature and pressure.

fps Feet per second. A measure of flow velocity. When used in gas flow, it is evaluated at a specific process temperature and pressure.

freezing point The fixed temperature point at which a material changes from a liquid to a solid state. This is the same as the melting point for pure materials. For example, the freezing point of water is 0°C or 32°F.

frequency The number of cycles over a specified period of time, usually measured in cycles per second. Also referred to as Hertz (Hz). The reciprocal is called the period.

fuse A device that protects electric circuits by interrupting power in a circuit when an overload occurs. Silicon controlled rectifiers (SCRs) require special, fast acting fuses, sometimes referred to as I²t (amps²-seconds) fuses.

Teflon® is a registered trademark of E.I. duPont de Nemours & Company.

Glossary

fuzzy logic A type of artificial intelligence logic that uses a percentage match to represent variable or inexact data, rather than the exactly true (1) or false (0) of binary logic.

G

gain The amount of amplification used in an electrical circuit. Gain can also refer to the proportional (P) mode of PID.

GGG Glass Glass Silicone. An optional heater lead wire covering, for Watlow cartridge or multicoil tubular heaters, made with two layers of fiberglass and a silicone binder.

giga (G) A prefix that means 10^9 (one billion in the US). Note: The word billion refers to different numbers in Europe and the US. In the US a billion is one thousand million (1,000,000,000). In Germany, England, France and other countries, a billion is one million million (100,000,000,000). That is a trillion in the US.

global alarm Alarm associated with a global digital output that is cleared directly from a controller or through a user interface.

gph Gallons per hour. A measure of the volumetric flow rate of a fluid.

gpm Gallons per minute. A measure of the volumetric flow rate of a fluid.

green rot See “preferential oxidation.”

ground An electrical line with the same electrical potential as the surrounding earth. Electrical systems are usually grounded to protect people and equipment from shocks due to malfunctions. Also called “safety ground.”

ground loop A condition created when two or more paths for electricity are created in a ground line, or when one or more paths are created in a shield. Ground loops can create undesirable noise.

grounded potential The electrical potential of the earth. A circuit, terminal or chassis is said to be at ground potential when it is used as a reference point for other potentials in the system.

grounded junction Type of thermocouple probe in which the hot, or measuring junction, is an integral part of the sheath material. No electrical isolation is provided.

GUI Graphic User Interface. A representation, on a computer screen, of a system or process that allows the computer user to interact with the system or process.

H

HAI-KN® A thermocouple alloy made of 95 percent nickel, two percent aluminum, two percent manganese and one percent silicon that is used as the negative conductor of ASTM Type K thermocouples. HAI-KN® is a registered trademark of the Harrison Alloys Company.

HAI-KP® A thermocouple alloy made of 90 percent nickel and 10 percent chromium used in the positive conductor of ASTM Type K and E thermocouples. HAI-KP® is a registered trademark of the Harrison Alloys Company.

Hastelloy® A family of related alloys (X, Alloy B2 and C276). Hastelloy® is a registered trademark of Haynes International.

HDPE Chemical abbreviation representing high-density polyethylene plastics.

heat Energy transferred between material bodies as a result of a temperature difference between them. See “Btu,” “calorie” and “Joule.”

heat transfer The flow of heat energy from one body of higher temperature to one of lower temperature.

heat treating thermocouple See “thermocouple” and “heat treating.”

heat/cool output filter A filter that slows the change in the response of the heat or cool output. The output responds to a step change by going to approximately $\frac{2}{3}$ its final value within the number of scans that are set.

heated insulation concept A description of one of the major features of the ceramic fiber heater product line from Watlow Columbia, that the insulation and heater element exist in one package.

heat sink Any object that conducts and dissipates heat away from an object in contact with it. Also a finned piece of metal, usually aluminum, that is used to dissipate heat generated by electrical and electronic devices.

Hertz (Hz) Frequency, measured in cycles per second.

high deviation alarm Warns that the process exceeds the set point by the high deviation value or more. It can be used as either an alarm or control function.

high process alarm Warns that the process exceeds a set value. It can be used as either an alarm or control function.

high process variable See “process variable.”

high reading An input level that corresponds to the high process value. For linear inputs, the high reading is a percentage of the full scale input range. For pulse inputs, the high reading is expressed in cycles per second (Hertz, Hz).

hi-pot test A test that applies a high voltage to a conductor to assure the integrity of the surrounding insulation. See “dielectric breakdown.”

hole fit The gap between the cartridge heater sheath and the part it fits into. The smaller this gap, the better the heater transfer to the part.

Glossary

hot change A feature of ceramic fiber and band heaters that allows individual heater replacement without total system shutdown or disassembly.

HTML Hypertext Markup Language. HTML uses tags and attributes to format documents displayed on a web browser.

HTTP Hypertext Transfer Protocol. The protocol used by the worldwide web that defines messages and transmissions between servers and clients.

hub connecting point in a star-configured LAN (local area network). A hub gathers individual network nodes together.

hunting Oscillation of a process value near the set point.

Hypalon® A synthetic rubber, chlorosulfonated polyethylene. Hypalon® is a registered trademark of the E.I. duPont de Nemours & Company.

hysteresis A change in the process variable required to re-energize the control or alarm output. Sometimes called switching differential.

I

I.D. Inside diameter.

ice point The temperature at which pure water changes from a liquid to a solid (freezes). 0°C (32°F).

idle set point Desired control value after a timing period.

IETF Internet Engineering Task Force. A collection of expert volunteers who by consensus set the engineering standards for Internet technology. The IETF is overseen by the Internet Society, an international, non-profit, membership organization focused on the expansion of the Internet.

IFC heated part Interference Fit Construction. A manufactured part with a specially designed groove milled into it with an IFC heater element permanently formed into the groove, creating intimate contact between the element and the part. IFC heated parts offer an alternative to milled groove heaters and brazed heater assemblies for application with temperatures too high for aluminum “cast-in” heated parts, or for environments where cast aluminum cannot be used.

i-key A toggle-action information key on controllers that provides context sensitive help in a display. Typically colored as “highway information sign blue,” i.e., Pantone 293C or equivalent.

impedance (Z) The total opposition of a circuit to the flow of alternating current. It includes resistance and reactance, and is measured in ohms.

Incoloy® A family of related alloys (800, 800X and 825). A registered trademark of the Special Metals Corporation (formally Inco).

Incoloy® 800 The standard heater protective sheath material, a nickel-iron-chromium alloy, and registered tradename of Special Metals Corporation, used for the Watlow FIREROD® heater. Incoloy® 800 is very corrosion- and temperature-resistant, and a key to the long-lived FIREROD® in high-temperature applications.

Inconel® A family of related alloys (600, 601, 625, X750). A registered trademark of the Special Metals Corporation (formerly Inco).

indication accuracy Closeness between the displayed value and a measured value. Usually expressed as a + or -, a percent of span or number of digits.

infrared A region of the electromagnetic spectrum with wavelengths ranging from one to 1,000 microns. These wavelengths are most suited for radiant heating and infrared (non-contact) temperature sensing.

initial calibration tolerance The allowable deviation from the theoretical EMF value generated by any particular thermocouple type at a given temperature. See “limit of error.”

input Process variable information that is supplied to the instrument.

input scaling The ability to scale input readings (readings in percent of full scale) to the engineering units of the process variable.

input type The signal type that is connected to an input, such as thermocouple, RTD, linear or process.

installed power Amount of power used for an application or process. It is the same as the kilowatt (kW) rating of installed heaters.

Instrument Society of America (ISA) An engineering society that defines and maintains standards for scientific and technical measuring devices.

insulation A material that electrically isolates a conductor from its surroundings, or thermally isolates an object from its surroundings.

insulation resistance The capacity of an insulation material to resist the flow of electricity. Expressed in ohms. See “dielectric strength.”

integral Control action that automatically eliminates offset, or droop, between set point and actual process temperature. See “reset” and “automatic reset.”

integral control (I) A form of temperature control. The I of PID. See “integral.”

interchangeability The ability to interchange system components with minimum effect on system accuracy.

Glossary

IP One of two primary protocols that internet hosts use. IP describes the message packet (datagrams or segment of messages) format. IP is network layer protocol defined by the IETF. See “TCP” and “TCP/IP.”

IPTS48, 68 International Practical Temperature Scales of 1948 and 1968. These have been superseded by ITS90. See “ITS90.”

iron The positive conductor in ASTM Type J thermocouples.

ISA See “Instrument Society of America.”

isolation junction A form of thermocouple probe construction in which the measuring junction is fully enclosed in a protective sheath and electrically isolated from it. Commonly called an ungrounded junction.

isolation Electrical separation of sensor from high-voltage circuitry. Allows use of grounded or ungrounded sensing element.

isothermal A process, volume or area that maintains a constant temperature.

ITS90 International Temperature Scale of 1990. The standard scale made of fixed points that closely approximate thermodynamic temperatures. All temperatures between the fixed points are derived by interpolation using the assigned interpolation instrument. Adopted in late 1993, this scale replaces both IPTS48 and 68.

J

jacket The outer covering on a wire or cable. It may provide electrical insulation and/or resistance to chemicals, abrasion and moisture.

JDA Joint Development Agreement. Specifies what role each party agrees to when developing a new product.

JIS See “Joint Industrial Standards.”

job A set of operating conditions for a process that can be stored and recalled in a controller’s memory. Also called a recipe.

Joint Industrial Standards (JIS) A Japanese agency that establishes and maintains standards for equipment and components. Also known as JISC (Japanese Industrial Standards Committee), its function is similar to Germany’s Deutsche Industrial Norm (DIN).

Joule A basic unit of heat energy, equal to the work done when a current of one ampere is passed through a resistance of one ohm for one second.

junction The point where two dissimilar metal conductors join to form a thermocouple.

K

Kapton® A lightweight organic polymer film that is a versatile dielectric material because of its tensile strength, dimensional stability and low emission of gas in vacuums. A registered trademark of the E.I. duPont de Nemours & Company.

Kelvin (k) An absolute temperature scale. Zero Kelvin is absolute zero. No degree symbol (°) is used with the Kelvin scale. (0°C = 273.15K, 100°C = 373.15K).

kilo (k) A prefix meaning thousand.

kilowatt (kW) Unit of electrical power equal to 1,000 watts or 3,412 Btus per hour when the power factor equals 1.0.

kilowatt hour (kWh) Unit of electrical energy, or work, expended by one kilowatt in one hour. Also expressed as 1,000 watt hours.

Nial® and Tophel® are registered trademarks of Carpenter Technology (Car Tech).

Chromel® and Alumel® are registered trademarks of Hoskins Manufacturing Company.

KN A thermocouple alloy made of 95 percent nickel, two percent aluminum, two percent manganese and one percent silicon that is used in the negative conductor of ASTM Type K thermocouples. Manufacturer trademarks for KN include Alumel®, Nial® and HAI-KN®.

KP A thermocouple alloy made of 90 percent nickel and 10 percent chromium that is used in the positive conductors of ASTM Type E and K thermocouples. Manufacturer trademarks for KP include Chromel®, Tophel® and HAI-KP®.

kVA Kilovoltampere or 1,000 voltamperes (VA). One unit of apparent power equals 1VA.

k-value The measure of a material’s thermal conductivity coefficient or its ability to conduct heat. Copper conducts better than plastic; copper has a higher k value. The k-value is expressed in W/cmK (watt per centimeter Kelvin) or in Btu/hft.F (Btu per hour per ft. degree Fahrenheit). The k-value is the reciprocal of the R-value, thermal resistance.

L

LA Lead Adaptor. Watlow’s patented method for adding a variety of options for leads and lead protection to stock heaters.

ladder logic An electrical circuit diagram schematic style that arranges the positive and negative sides of the power input as the two main beams of a vertical ladder, and arranges the connections between them as the rungs of the ladder.

lag The amount of time delay between two related parts of a process or system.

HAI-KN® and HAI-KP® are registered trademarks of Harrison Alloys Company.

Glossary

LAN Local Area Network. A computer network in a single physical location. LANs can be connected together in a Wide Area Network (WAN).

latent heat of fusion (H_f) The amount of heat energy, expressed in Btu/lb or Joule/gram, required to change a solid to a liquid without an increase in temperature.

latent heat of vaporization (H_v) The amount of heat energy, expressed in Btu/lb or Joule/gram, required to change a liquid to a vapor without an increase in temperature.

lava cone Low temperature silicate-based insulator used between electrically conductive and non-conductive casings or tubes.

LCP Liquid Crystal Polymer. A high-temperature thermoplastic with good impact strength.

LED See "light emitting diode."

leg One connection in an electric circuit.

light emitting diode (LED) A solid-state electronic device that glows when electric current passes through it.

limit of error A tolerance band of the thermal electric response of thermocouple wire, expressed as a percentage or a specific degree value in defined temperature ranges, defined by the ASTM specification MC96.1 (1982).

limit or limit controller A highly reliable, discrete safety device (redundant to the primary controller) that monitors and limits the temperature of the process, or a point in the process. When temperature exceeds or falls below the limit set point, the limit controller interrupts power through the load circuit. A limit controller can protect equipment and people when it is correctly installed with its own power supply, power lines, switch and sensor.

linear input A process input that represents a straight line function.

linearity The deviation in response from an expected or theoretical straight line value for instruments and transducers. Also called linearity error.

linearization, input See "linearization" and "square root."

linearization, square root The extraction of a linear signal from a nonlinear signal corresponding to the measured flow from a flow transmitter. Also called square root extraction.

liquid crystal display (LCD) A type of digital display made of a material that changes reflectance or transmittance when an electrical field is applied to it.

load The electrical demand of a process, expressed in power (watts), current (amps) or resistance (ohms). The item or substance that is to be heated or cooled.

local set point The primary set point.

loop See "control loop."

loop alarm Any alarm system that includes high and low process, deviation band, dead band, digital outputs, and auxiliary control outputs.

loop resistance The total resistance of the conducting materials in a thermocouple circuit.

low deviation alarm Warns that the process is below the set point by the low deviation value or move process variable. It can be used as either an alarm or control function.

low process alarm Warns that the process is below a set value. It can be used as either an alarm or control function.

low process variable See "process variable."

low reading An input level corresponding to the low process value. For linear inputs, the low reading is a percentage of the full scale input range. For pulse inputs, the low reading is expressed in cycles per second, Hertz (Hz).

M

manual mode A selectable mode without automatic control. The operator sets output levels. Same as open loop control.

manual reset 1) A feature on a limit control that requires human intervention to return the limit to normal operation after a limit condition has occurred. 2) The adjustment of a proportional control to raise the proportional band to compensate for droop.

mass flow rate The amount of a substance that flows past a given cross-section area of a conduit in a given unit of time.

master A device that transmits a set point signal to other controlling devices, called remotes.

maximum load impedance The largest load that the output device can operate. Usually specified in ohms.

maximum operating temperature The highest temperature at which a device can operate safely, or with expected normal service life.

maximum power rating The maximum operating power at which a device can operate safely or with expected normal operating life.

MCDA Mutual Confidential Disclosure Agreement. A legal document that spells out mutual provisions for both parties, and the conditions and circumstances in which confidential information can be shared by both parties, and the remedies required for violations.

Glossary

MDR See “relay, mercury displacement.”

measuring junction See “junction.”

measuring junction The thermocouple junction that is affixed to or inserted into the material being measured. Also called hot junction.

mega (M) A prefix that means one 10^6 (one million in the US).

megawatt (MW) 1×10^6 watts or 1,000,000 (one million) watts.

melting point The temperature at which a substance changes from a solid to liquid state. This is the same as the freezing point of pure materials.

menu A list of options from which the operator can select the tasks to be done.

mercury displacement relay (MDR)

A power switching device in which mercury, displaced by a plunger, completes the electric circuit across contacts.

metal fatigue A breakdown in metal strength caused by mechanical action. For example, when sheath and conductor materials have different linear expansion coefficients, heating and cooling cause mechanical movement that induces strain. Metal fatigue shortens the life of the heater and the thermocouple.

MGT Mica Glass Teflon®. An optional heater lead wire covering, used with several Watlow heater lines, made with mica, fiberglass and a Teflon® binder.

MI leads Mineral Insulated leads. A Watlow LA (Lead Adaptor) termination option for cartridge heaters that handles both high temperatures up to 815°C (1,500°F) and contamination, such as moisture, gases, oils, plastic drool, solvents and water.

MIB Management Information Base A database of defined properties of objects that can be monitored or manipulated by a network administrator via an SNMP agent.

mica A silicate material used primarily as an electrical and heat insulator.

micron A unit of length. One micron is equivalent to 10^{-6} meters.

microvolt (μ V) One 10^{-6} of a volt (one millionth in the US).

mil One thousandth of an inch, or 0.001 inches in decimal form.

milled groove A machined groove milled into a part to accept a heater shaped to fit the groove.

milliampere (mA) One 10^{-3} (thousandth) of an ampere.

millivolt (mV) One 10^{-3} (thousandth) of a volt.

mineral insulated thermocouple A thermocouple probe constructed by loading a metal sheath with thermocouple conductors and a mineral-based dielectric material, then compacting the entire assembly.

minimum load current The smallest load current required to ensure proper operation of an output switching device.

minimum output impedance See “offstate impedance.”

MNPT informal; Male (external) National Pipe Thread.

MO Magnesium Oxide. The powdered chemical compound used in heater manufacturing to insulate the resistance wire from the metal sheath. This high grade material also contributes to the long life of Watlow heaters.

MODBUS™ protocol driver A software program subroutine that converts programming language- or operating system-specific instructions to the MODBUS™ protocol for a MODBUS™ device.

moisture resistance The relative ability to resist permeation by water.

Monel® An alloy made of nickel and copper sensor sheath that is used to make sensor sheaths. It exhibits excellent resistance to sea water; to hydrofluoric, sulfuric and hydrochloric acids; and to most alkalis. Monel® is a registered trademark of the Special Metals Corporation (formally Inco).

multilayer hybrid A hybrid circuit constructed of alternating conductive and insulating layers. The multilayer structure combines very dense packaging of electronics with good ability to remove generated heat. Multilayers are typically built through repeated firings as layers are added and are typically constructed with gold, silver-palladium or copper conductors.

Mylar® Terephthalate (polyester) film. A registered trademark of the E.I. duPont de Nemours & Company.

N

National Bureau of Standards (NBS) Now called the National Institute of Standards Technology (NIST).

National Electrical Code (NEC) A set of specifications devised for the safe application and use of electric power and devices in the United States.

National Electrical Manufacturers Association (NEMA) A United States association that establishes specifications and ratings for electrical components and apparatuses. Conformance by manufacturers is voluntary.

National Institute of Standards and Technology (NIST) A United States government agency responsible for establishing scientific and technical standards. Formerly the National Bureau of Standards.

National Pipe Thread (NPT) The taper pipe thread standard used in North America.

Glossary

NBS See “National Bureau of Standards.”

NEC See “National Electrical Code.”

negative temperature coefficient A decrease in electrical resistance that occurs with a temperature increase. See “thermistor.”

NEMA See “National Electrical Manufacturers Association.”

NEMA 4X A NEMA specification for determining resistance to moisture infiltration and corrosion resistance. This rating certifies the controller as washable and corrosion resistant.

neoprene A synthetic rubber, also referred to as polychloroprene, that exhibits good resistance to oil, chemicals and flame.

NetBios Network Basic Input Output System. An application programming interface (API) that adds special network functions to a computer’s basic operating system.

Network Layer (OSI Layer 3) The third layer of the seven-layer OSI (Open System Interconnection) protocol model that handles switching, routing, and packet sequencing between nodes on a network. The Network Layer resides between the Transport Layer and the Data Link Layer.

Nial® A thermocouple alloy made of 95 percent nickel, two percent aluminum, two percent manganese and one percent silicon that is used in the negative conductor of ASTM Type K thermocouples. Nial® is a registered trademark of Carpenter Technology.

nicrosil A thermocouple alloy that is made of 84.6 percent nickel, 14.0 percent chromium and 1.4 percent silicon. It is used in the positive conductor of an ASTM Type N thermocouple.

nisil A thermocouple alloy that is made of 95.6 percent nickel and 4.4 percent silicon. It is used in the negative conductor of an ASTM Type N thermocouple.

NIST See “National Institute of Standards and Technology.”

no key reset A method for resetting the controller’s memory (for instance, after an EPROM change).

noble metal thermocouple The general designation for thermocouples with conductors made of platinum and/or platinum alloys (ASTM Types B, R and S). They are used in high-temperature or corrosive applications.

node A connection point on a computer network for one computer or other addressable device, such as a printer.

no-heat The part of a Watlow heater intentionally designed as unheated, or as an unheated extension, outside the resistance wire (heater coil) area. The no-heat area has a lower temperature due to heat losses of various types: radiation; conduction; or convection.

noise Unwanted electrical signals that usually produce signal interference in sensors and sensor circuits. See “electromagnetic interference (EMI).”

noise suppression The use of components to reduce electrical interference that is caused by making or breaking electrical contact, or by inductors.

Nomex® A temperature-resistant, flame retardant nylon compound that is used as a wire insulation. A registered trademark of E.I. duPont de Nemours & Company.

NPT See “National Pipe Thread.”

NPT American National Standard Taper Pipe Thread as defined by ANSI B1.20.1.

NSF 1) National Sanitation Foundation; 2) National Science Foundation.

NUWARMTH® A Watlow wholly-owned subsidiary that produces and markets consumer-focused thermopolymer products primarily for the home and automotive industries.

nylon A thermoplastic that is commonly used as an insulation because it exhibits excellent abrasion and good chemical resistance.

O

O.D. Outside diameter.

offset Synonym for “droop.” In a stable thermal system, the difference between the process set point and the process actual temperature. An offset variable can be introduced intentionally into the system by some controllers to compensate for sensor placement. In PID control, integral (reset) will eliminate droop.

offstate impedance The minimum electrical resistance of the output device in the off, or de-energized, state. It is based on the frequency of the load supply current plus internal and/or external noise suppression devices.

OFHC Oxygen-free, high conductivity copper. The pure copper used in the positive conductor of an ASTM Type T thermocouple.

ohm (Ω) The unit of electric resistance. The resistance value through which one volt will maintain a current of one ampere. See “Ohm’s Law.”

Ohm’s Law Current in a circuit is directly proportional to the voltage, and inversely proportional to resistance; stated as: $E = IR$, $I = E/R$, $R = E/I$, $P = EI$ where I = current in amperes, E = EMF in volts, R = resistance in ohms and P = power in watts.

Glossary

OID ("oh-eye-dee") Object Identifier. In the NAFEM (National Association of Food Equipment Manufacturers) context, Object Identifiers form an index of attributes of a supplier's programmable objects in a data protocol model. Object identifiers derive from the SNMP standard.

on-off A method of control that turns the output full on until set point is reached, and then off until the process error exceeds the hysteresis.

on-off controller A temperature controller that operates in either full-on or full-off state.

open loop A control system with no sensory feedback. See "manual mode."

operator menus The menus accessible from the front panel of a controller. These menus allow operators to set or change various control actions or features.

optical isolation Two electronic networks that are connected through an LED (light emitting diode) and a photoelectric receiver. There is no electrical continuity between the two networks.

OSHA Occupational Safety and Health Act. Also the Occupational Safety and Health Agency, the United States governmental agency that establishes and enforces safety standards in the workplace.

OSI Reference Model (Open System Interconnection, ISO/IEC 7498-1) A seven-layered model for developing and implementing communication among systems. Control passes from one layer to the next and back again, beginning at the application layer in the system that initiates the communication. The reference model provides a common basis for the coordination of standards development for the purpose of systems interconnection from ISO/IEC 7498-1.

output The control signal that affects the and process value.

output type The form of PID control output, such as time proportioning, distributed zero crossing, serial digital-to-analog converter or analog. Also the description of the electrical hardware that makes up the output.

overshoot The amount by which a process variable exceeds the set point before it stabilizes.

P

P control Proportioning control.

panel lock A feature that prevents operation of the front panel.

parallel circuit A circuit configuration in which the same voltage is applied to all components, with current divided among the components according to their respective resistances or impedances.

parameter 1. A variable that is given a constant value for a specific application or process. 2. A value that determines the response of an electronic controller to given inputs.

passivation A process for treating stainless steel surfaces, usually with dilute nitric acid to remove contaminants, and to apply a passive film protecting the fresh metal surface.

passive component A component whose properties do not change with changes in the applied signal. Resistors, capacitors and inductors are passive components.

PC See "polycarbonate."

PD control Proportioning control with derivative (rate) action.

PDR control Proportional derivative control with manual reset, used in fast responding systems where the reset causes instabilities. With PDR control, an operator can enter a manual reset value that eliminates droop in the system.

PEI See "polyetherimide."

Peltier Effect Inverse of Seebeck effect, used in thermoelectric applications. See "Seebeck" effect.

percent power control Open-loop control with output power set at a particular level.

percent power limit Restriction of output power to a predetermined level.

PET Chemical abbreviation for polyethylene terephthalate.

PFA Chemical abbreviation representing a perfluoroalkyl group. See "Teflon®."

phase The time-based relationship between alternating current cycles and a fixed reference point. In electricity, it is usually expressed in angular degrees, with a complete cycle equal to 360°. It describes the relationships of voltage and current of two or more alternating waveforms.

phase-angle firing A mode of power control in silicon controlled rectifiers (SCRs). Phase-angle firing varies the point at which the SCR switches voltage inside the AC sine wave.

Physical Layer (OSI Layer 1) The first and lowest layer of the seven-layer OSI (Open System Interconnection) protocol model where bits of information move through the physical medium or space. The Physical Layer includes the hardware means of moving the information. The Physical Layer resides below the Data Link Layer.

PI control Proportioning control with integral (automatic reset) action.

PID Proportional, Integral, Derivative. A control mode with three functions: proportional action dampens the system response, integral corrects for droop, and derivative prevents overshoot and undershoot.

Glossary

ping Packet Internet groper. A computer utility used to troubleshoot Internet connections. Ping verifies that a specific IP address is available.

plastic Natural and synthetic polymeric substances, excluding rubbers, that flow under heat and/or pressure. See <http://www.plasticstechnology.com/materials/index.html> for an extensive materials database, including abbreviations, properties, features, etc.

Platinel® A nonstandard platinum alloy with thermoelectric characteristics that closely match ASTM Type K thermocouples at temperatures above 800°C (1440°F). Platinel® is a registered trademark of Englehard Industries.

platinum (Pt 2) A noble metal that is more ductile than silver, gold or copper, and has excellent chemical and heat resistant characteristics. It is used in the negative conductor in ASTM Types R and S thermocouples.

platinum 10 percent rhodium The platinum-rhodium thermocouple alloy that forms the positive conductor on ASTM Type S thermocouples.

platinum 13 percent rhodium The platinum-rhodium thermocouple alloy that forms the positive conductor on ASTM Type R thermocouples.

platinum 30 percent rhodium The platinum-rhodium thermocouple alloy that forms the positive conductor on ASTM Type B thermocouples.

platinum 6 percent rhodium The platinum-rhodium thermocouple alloy that forms the negative conductor on ASTM Type B thermocouples.

platinum 67 An NIST platinum standard. Platinum 67 is used to interpolate the temperature scale between 630.74 and 1064.43°C (1167.33 and 1947.97°F). Replacing platinum 27, platinum 67 (IPTS68) is nine microvolts negative to platinum 27.

polarity The electrical quality of having two opposite poles, one positive and one negative. Polarity determines the direction in which a current tends to flow.

poll engine A software application dedicated to continuously requesting data from connected devices on a network.

polycarbonate (PC) A thermoplastic that offers high strength and toughness.

polyester A broad class of polymers possessing good moisture resistance and electrical properties.

polyetherimide (PEI) A high-temperature thermoplastic with excellent strength and chemical resistance.

polyethylene (PE) A thermoplastic that exhibits excellent dielectric characteristics.

polymer Any substance made of many repeating chemical molecules. Often used in place of plastic, rubber or elastomer.

polyphenylene sulfide (PPS) A high-temperature thermoplastic with good solvent resistance and flame retardation.

polypropylene A thermoplastic that is similar to polyethylene, but has a higher softening point (temperature).

polysulfone (PSU) A thermoplastic with excellent water and similar fluid resistance.

polyurethane (PUR) A broad class of polymers that has good abrasion and chemical resistance.

polyvinyl chloride (PVC) A thermoplastic with excellent dielectric strength and flexibility.

positive temperature coefficient (PTC) An increase in resistance that occurs with an increase in temperature. See “resistance temperature detector” and “thermistor.”

potting The sealing of components and associated conductors with a compound to exclude moisture and contaminants.

power factor (PF) The ratio of real power (P_R) to apparent power (P_A).

power loss alarm Associated with latching limit controls, the limit control recognizes a power outage as a limit condition. Manual reset is required to re-energize the output after power is restored.

PPS See “polyphenylene sulfide.”

pre-aging A process by which a thermocouple is subjected to application conditions that cause most of any electromagnetic force shift (decalibration). When it is installed and calibrated to an instrument, a pre-aged thermocouple will produce reliable readings.

preferential oxidation Commonly called green rot. A phenomenon peculiar to nickel-based thermocouples, most often ASTM Type K, when oxygen is limited. The limited oxygen reacts with the more active chromium in the conductor alloy, which changes to chromium oxide and creates a green scale. An increasing nickel skin is left behind, causing decalibration. Decalibration is caused when the negative thermoelement is paired against a nickel skin and not the original homogeneous nickel-chromium alloy. Preferential oxidation will not occur when there is an abundant supply or a total absence of oxygen.

presentation layer (OSI Layer 6) The sixth layer of the seven-layer OSI (Open System Interconnection) protocol model where syntax, compatibility, and encryption issues are resolved. The Presentation Layer resides between the Application Layer and the Session Layer.

Glossary

primary standard An instrument that meets conditions required by the International Temperature Scale (ITS90).

probe A temperature sensor. A probe may contain a thermocouple, RTD, thermistor or integrated circuit (IC) sensor.

process alarm Warns that process values are outside the process alarm range. A fixed value independent of the set point.

process error The difference between the set point and the actual process value.

process variable The parameter that is controlled or measured. Typical examples are temperature, relative humidity, pressure, flow, fluid level, events, etc. The high process variable is the highest value of the process range, expressed in engineering units. The low process variable is the lowest value of the process range.

programmed display data Displayed information that gives the operator the intended process information, such as intended set point, intended alarm limit, etc., corresponding to temperature or other engineering units.

prompt A symbol or message displayed by the computer or controller that requests input from the user.

proportional Output effort proportional to the error from set point. For example, if the proportional band is 20° and the process is 10° below set point, the heat proportioned effort is 50 percent. The lower the PB value, the higher the gain.

proportional band (PB) A range in which the proportioning function of the control is active. Expressed in units, degrees or percent of span. See “PID.”

proportional control A control using only the P (proportional) value of PID control.

protection head An enclosure that protects the electrical connections of heaters or sensor probes.

protection tube A tube that protects a sensor (thermocouple, RTD or thermistor) from harsh environmental or process conditions.

psia Pounds per square inch absolute. Pressure expressed in terms of its actual or absolute value with reference to a perfect vacuum. psia = psig + 14.7 psi (1 atmosphere). See “psig.”

psig Pounds per square inch gauge. Pressure expressed in terms of a value read directly from installed gauges. psig = psia - 14.7 psi (1 atmosphere). See “psia.”

PSU See “polysulfone.”

PTFE Chemical abbreviation for polytetrafluoroethylene. See “Teflon®” and “TFE.”

pulse input Digital pulse signals from devices, such as optical encoders.

PVC See “polyvinyl chloride.”

Q

quality Thermodynamic term that indicates the relative amount of liquid present in saturated steam as a percent of the total weight. The quality of steam is 100 percent minus the percent of liquid. Dry saturated steam has a quality of 100 percent.

R

radiation Radiant energy emitted in the form of waves or particles. See “emissivity” and “infrared.”

radio frequency interference (RFI) Electromagnetic waves between the frequencies of 10kHz and 300GHz that can affect susceptible systems by conduction through sensor or power input lines, and by radiation through space.

ramp A programmed increase in the temperature of a set point system.

range The area between two limits in which a quantity or value is measured. It is usually described in terms of lower and upper limits.

rate Anticipatory action that is based on the rate of temperature change, and compensates to minimize overshoot and undershoot. See “derivative.”

rate band A range in which the rate function of a controller is active. Expressed in multiples of the proportional band. See “PID.”

ratio A method by which the controller measures the flow of an uncontrolled variable and uses a portion of it to control the flow of a second variable.

recipe See “job.”

reference junction The known temperature point at which a thermocouple or its extension wire connects to a temperature measurement instrument or controller. To prevent an error from introducing itself at this point, some instruments will add a compensation value to the signal. Also called the “cold junction.”

reflection compensation mode A control feature that automatically corrects the reading from a sensor.

reflective energy Energy from the background that causes an error when an infrared sensor measures the radiant energy of a specific object.

refractory metal thermocouple A thermocouple made from materials such as tungsten and rhenium, which melt above 1935°C (3515°F). These are non-ASTM types C, D and G.

relative thermal index (RTI) A long-term heat aging test used by Underwriter’s Laboratories (UL®) to determine the maximum application temperature for plastics.

relay A switching device.

Glossary

remote A controller that receives its set point signal from another device called the master.

remote set point A signal from another device that indicates the set point for the process.

repeatability The ability to provide the same output or reading under repeated, identical conditions. See “stability.”

reset Control action that automatically eliminates offset, or droop, between set point and actual process temperature. Also see “integral.”

reset windup inhibit See “anti-reset wind-up.”

resistance Opposition to the flow of electric current, measured in ohms. See “ohms.”

resistance temperature characteristic The characteristic change in a sensor’s resistance when exposed to a change in temperature. See “positive temperature coefficient” and “negative temperature coefficient.”

resistance temperature detector (RTD) A sensor that uses the resistance temperature characteristic to measure temperature. There are two basic types of RTDs: the wire RTD, which is usually made of platinum, and the thermistor, which is made of a semiconductor material. The wire RTD is a positive temperature coefficient sensor only, while the thermistor can have either a negative or positive temperature coefficient.

resistive loads All loads that limit the flow of electric current. With pure resistive loads, voltage and current are in phase.

resolution An expression of the smallest input change unit detectable at a system output.

response time (time constant) 1) The time required by a sensor to reach 63.2 percent of a temperature step change under a specified set of conditions. Five time constants are required for the sensor to stabilize at 100 percent of the step change value. 2) With infrared temperature sensing, the time required for a sensor to reach 95 percent of a step change. This is known as the time constant times three. The overall system response time is the sum of the time constants of each component.

retransmit output An analog output signal that may be scaled to represent the process value or set point value.

reverse action An output control action in which an increase in the process variable causes a decrease in the output. Heating applications usually use reverse action.

RFI See “radio frequency interference.”

rhenium (Re) A metallic element that, when added to tungsten, forms an alloy with better ductility and higher temperature strength than tungsten alone.

rhodium (Rh) A metallic element inside the platinum group that, when added to pure platinum, forms an alloy with reduced ductility and better high temperature strength than platinum alone.

router A device that connects one computer local area network (LAN) to another using ICMP (Internet Control Message Protocol), part of IP (Internet Protocol), to communicate with other routers, and to determine optimum data paths.

RTD See “resistance temperature detector.”

RTI See “relative thermal index.”

rubber insulation A general designation for thermosetting elastomers, such as natural and synthetic rubbers, neoprene, Hypalon®, and butyl rubber. They are used to insulate wire conductors. Hypalon® is a registered trademark of the E.I. duPont de Nemours & Company.

S

SAE See “Society of Automotive Engineers.”

safety limit An automatic limit intended for use in applications where an over-temperature fault may cause a fire or pose other safety concerns.

SAMA See “Scientific Apparatus Makers Association.”

saturation pressure The pressure on a liquid when it boils at a given temperature. Both the saturated liquid and saturated vapor phases can exist at this time.

saturation temperature The boiling temperature of a liquid at its existing pressure.

scfm Standard volumetric flow rate in cubic feet per minute. A measure of the flow rate of gases and vapors under standard conditions of 15°C (60°F) and standard atmospheric pressure.

Scientific Apparatus Makers

Association (SAMA) An association that sets standards for platinum, nickel and copper resistance elements (RTDs).

SCR See “silicon controlled rectifier.”

Glossary

screen printing A printing method that uses a photographic process to create an image on a fine screen, and then transfers that image to another surface with a squeegee forcing ink or other viscous material through the mesh of the screen. Watlow uses screen printing in both traditional product labeling and in thick film manufacturing.

secondary standard A measurement device that refers to a primary standard.

Seebeck coefficient The rate of change (derivative) of thermal EMF (voltage) with respect to temperature. Expressed as millivolts per degree.

Seebeck effect When a circuit is formed with a junction of two dissimilar metals and the junctions at each end are held at different temperatures, a current will flow in the circuit.

Seebeck EMF The net thermal electromotive force (EMF) in a thermocouple under conditions of zero current.

semiconductor Any material that exhibits a degree of electrical conductivity that falls between that of conductors and dielectrics.

serial communications A method of transmitting information between devices by sending all bits serially over a single communication channel.

series circuit A circuit configuration in which a single current path is arranged among all components.

server A device or computer on a network that serves or delivers network resources, such as a file server, database server, print server or web server.

serving The process by which metallic or nonmetallic filaments or fibers are woven around a wire conductor to produce electrical insulation, shielding or improved abrasion resistance. See “braid.”

Session Layer (OSI Layer 5) The fifth layer of the seven-layer OSI (Open System Interconnection) protocol model that starts, stops and manages connections between applications. The Session Layer resides between the Presentation Layer and the Transport Layer.

set point The desired value programmed into a controller. For example, the temperature at which a system is to be maintained.

setpot A potentiometer used to adjust controller set point temperature.

setting accuracy Closeness between the value established by an input device, such as a dial, and the desired value. Usually expressed as a percent of span or number of digits.

SFPM Standard flow velocity in feet per minute. For gas flow, it is evaluated using the SCFM (standard cubic feet per minute) divided by the flow area.

sfp Standard flow velocity in feet per minute. Gas flow is calculated using scfm divided by the flow area.

shape factor The amount of energy a target object receives, relative to the size of the heater and its distance from the object.

sheath thermocouple A mineral-insulated thermocouple that has an outer metal sheath. It is usually made from mineral-insulated thermocouple cable.

shield A metallic foil or braided wire layer surrounding conductors that is designed to prevent electrostatic or electromagnetic interference from external sources.

shield coverage See “shield percentage.”

shield effectiveness The relative ability of a shield material to screen interference. Shield effectiveness is often confused with shield percentage.

shield percentage The area of a circuit or cable that is covered by a shielding material, expressed as a percentage.

shunt In an electrical circuit, a low resistance connection between two points that forms an alternate path for some of the current. Dielectric materials lose resistance at temperatures above their operating range. This condition can cause shunting of the sensor’s signal, causing an error in the reading.

SI Systems Internationale. The system of standard metric units.

signal Any electrical transmittance that conveys information.

silicon A tetravalent nonmetallic element.

silicon controlled rectifier (SCR) A solid-state device, or thyristor, with no moving parts, that is used in pairs to control ac voltages within one cycle. SCRs control voltage from a power source to the load by burst firing (also called zero-cross firing) or phase angle firing. See “burst fire.”

silicone A thermosetting elastomer that is made of silicone and oxygen, and noted for high heat resistance.

silicone rubber Rubber that is made from silicone elastomers and noted for its retention of flexibility, resilience and tensile strength.

slidewire feedback A method of controlling the position of a valve. using a potentiometer. The resistance indicates the valve position.

SMTP Simple Mail Transfer Protocol. A protocol that enables e-mail servers and clients to send e-mail.

Glossary

SNMP Simple Network Management Protocol. Protocols for managing complex networks. SNMP exists at the Presentation (Layer 6) and Application (Layer 7) layers of the seven-layer Open System Interconnection (OSI) model, from standard ISO/IEC (International Organization for Standardization/International Electrotechnical Commission) 7498-1.

SNMP agent A means for a network administrator to communicate with an object within a specific device on a network.

SNMP manager A network administrator's interface for performing network management tasks on a network's Simple Network Management Protocol layers.

soaking In heat treating, the practice of immersing an object in a heated environment so it can complete a desired metallurgical change at a specific temperature.

Society of Automotive Engineers (SAE) A society that establishes standards for the transportation industries (automotive, marine and aviation), including the system of English units (pounds, feet, gallons, etc.).

soft start A method of using phase-angle SCR control to gradually increase the output power over a period of several seconds. Soft starts are used for heaters that have a low electrical resistance when they are cold, or for limiting in-rush current to inductive loads.

software Instructions that enable a computing device 1) to function, as in an operating system, or 2) to perform specific tasks, as in applications. These instructions are typically stored in some type of memory media.

solid-state relay (SSR) A switching device with no moving parts that completes or interrupts a circuit electrically.

span The difference between the lower and upper limits of a range expressed in the same units as the range. See "range."

spark test A high voltage, low amperage test that detects insulation defects in wire and cable.

specific gravity (sp. gr.) Density relative to the density of water, which is given the arbitrary value of one at 0°C. See "density."

specific heat capacity The quantity of heat (in joules or Btus) necessary to raise the temperature of one kilogram (or pound) of substance through 1 Kelvin. In most materials, specific heat capacity varies with changes in temperature and material state.

specific volume The inverse of density, expressed in units of cubic feet per pound or cubic meters per kilogram.

spectral filter A filter that restricts the electromagnetic spectrum to a specific bandwidth, such as four to eight microns infrared radiation.

spectral response band The region of the infrared portion of the electromagnetic spectrum over which an infrared sensor processes a signal. Infrared sensors that operate at shorter wavelengths are designed for higher temperatures.

spot size See "field of view."

spread In heat/cool applications, the difference between heat and cool. Also known as process dead band. See "dead band."

SSR See "solid state relay."

stability The ability of a device to maintain a constant output with the application of a constant input.

standard A set value or reference point from which measurements or calibrations are made.

standard wire error The level of deviation from established standards. Usually expressed in terms of $\pm^\circ\text{C}$ or percent. Also known as standard tolerances.

subnet Part of a TCP/IP network that shares the same IP address prefix. Networks are divided into subnets to increase performance and security.

superheat Heating of a gas or vapor to a temperature well above its dry saturation temperature. This term will be encountered frequently when working with steam. These temperatures, coupled with the tabulated enthalpy values, provide a simple means of calculating the power needed for superheating.

surge current A short duration rush of current that occurs when power is first applied to capacitive, inductive or temperature dependent resistive loads, such as tungsten or silicon carbide heating elements. It also occurs when inductive loads are de-energized. Surge currents usually last no more than several cycles.

swage Uniform compaction process that decreases the diameter and increases the length of a cylinder. This compaction process used in cartridge heater and sensor manufacturing, creates higher thermal conductivity (better heat transfer) and greater dielectric strength (longer life). The unit can be swaged multiple times, known as double swaging.

switch 1) A device, either electrical or mechanical, used to open or close an electrical circuit. 2) A computer programming technique that will change a selection from one state to another. 3) A telephone interface that connects callers. 4) A network routing device that provides numbered nodes, one for each connected device.

switching differential See "hysteresis."

Glossary

switching sensitivity In on-off control, the temperature change necessary to change the output from full on to full off. See “hysteresis.”

Systems Internationale (SI) The system of standard metric units.

T

TCP Transmission Control Protocol. One of two primary protocols that distinct Internet hosts use to establish a connection and exchange data while ensuring that data packets are received in the same order as they were sent. TCP is a session-based transport layer protocol defined by the IETF. See “IP” and “TCP/IP.”

TCP/IP Transmission Control Protocol/Internet Protocol. The two primary protocols used to connect hosts and exchange data on the Internet.

TD Timed derivative. The derivative function.

Teflon® A registered trademark of E.I. duPont de Nemours & Company, covering a family of fluorocarbon materials that includes FEP, PFA and PTFE.

Tefzel® (ETFE) Fluoropolymer material, ethylene tetrafluoroethylene, with excellent mechanical properties, particularly important in wire and cable applications. Tefzel® is a registered trademark of the E.I. duPont de Nemours & Company.

Telecommunication Industry Association (TIA) A trade group that sets standards for the telecommunications industries.

temperature calibration point A temperature at which the output of a sensor is compared against a standard.

temperature limit switch Factory Mutual (FM) Standard 3545. See “limit control.”

temperature, ambient The temperature of the air or other medium that surrounds the components of a thermal system.

tera (T) A prefix meaning 10^{12} (one trillion in the US).

TFE A common short hand abbreviation for **PTFE**, polytetrafluoroethylene, or Teflon®.

thermal conductivity The quantity of heat transmitted by conduction through a body per unit area, per unit time, per unit thickness for a temperature difference of 1 Kelvin. This value changes with temperature in most materials and must be evaluated for conditions given. Expressed in Btu/hr-ft-°F or Watts/meter-°C.

thermal EMF The ability of a thermocouple to produce a voltage that increases or decreases in proportion to its change in temperature.

thermal expansion An increase in the size of a material that is caused by an increase in temperature. Expressed as the number of inches/inch/°F or cm/cm/°C per reference length.

thermal gradient The distribution of differential temperatures through a body or across a surface.

thermal lag The delay in the distribution of heat energy throughout a system. Thermal lag can cause process temperature instability.

thermal shunt A condition in which the mass of the sensor absorbs a portion of the heat being measured, which results in an erroneous reading.

thermal system A regulated environment that consists of a heat source, heat transfer medium or load, sensing device and a control instrument.

thermistor A temperature sensing device made of a semiconductor material that exhibits a large change in resistance for a small change in temperature. Thermistors usually have negative temperature coefficients, although they are also available with positive temperature coefficients.

thermocouple (T/C) A temperature sensing device made by joining two dissimilar metals. This junction produces an electrical voltage in proportion to the difference in temperature between the hot junction (sensing junction) and the lead wire connection to the instrument (cold junction).

thermocouple aging or aging range A positive shift in electromotive force (EMF) in nickel-based thermocouple alloys that is caused by a temperature gradient along the thermocouple elements. Factors that cause EMF shift are the measured temperature, the previous thermal history of the element, the amount of time spent at the aging temperature and the amount of the element subjected to the aging temperature. Different thermocouple types age differently under different application conditions.

thermocouple break protection The ability of a control to detect a break in the thermocouple circuit and take a predetermined action.

thermocouple extension wire A pair of wires connecting a thermocouple sensor to its reference junction or instrumentation. The electromotive force (EMF) characteristics of the extension wire must be similar to the EMF characteristics of the thermocouple.

Glossary

thermocouple junction The point where the two dissimilar metal conductors join. In a typical thermocouple circuit, there is a measuring junction and a reference junction. See “junction,” “measuring junction” and “reference junction.”

thermocouple pre-aging See “pre-aging.”

thermocouple type A particular combination of metallic elements and/or alloys that make up the conductors of a thermocouple, and defines their EMF output relative to absolute temperature. ASTM designated types include: B, E, J, K, N, R, S and T. Non-ASTM types include: C, D and G (tungsten based thermocouples) and Pt 2.

thermocouple, heat treating A thermocouple that is appropriate for the temperature range and atmospheres used in heat treating. Heat treating is a process that alters the physical properties of a metal by heating and cooling at specific rate changes, and by introducing chemical atmospheres.

thermopile An arrangement of thermocouples in a series with alternate junctions at the measuring temperature and the reference temperature. This arrangement amplifies the thermoelectric voltage. Thermopiles are usually used in infrared detectors in radiation pyrometry.

thermopolymer technology The technology that applies heated plastics to applications.

thermoset A material that undergoes a chemical reaction and is cured or set when subjected to heat. An example is bakelite. Thermosetting also applies to vulcanizing, as with rubber and neoprene.

thermowell A tube with a closed end that is designed to protect temperature sensors from hostile environments. See “protection tube.”

Thompson Effect When a current flows through a conductor within a thermal gradient, a reversible absorption or evolution of heat occurs in the conductor at the gradient boundaries.

three-mode control Proportioning control with integral (reset) and derivative (rate). Also see “PID.”

TI Integral term.

TIA See “Telecommunications Industry Association.”

time proportioning control A method of controlling power by varying the on-off duty cycle of an output. This variance is proportional to the difference between the set point and the actual process temperature.

Tophel® A thermocouple alloy that is made of 90 percent nickel and 10 percent chromium. It is used in the positive conductors of ASTM Type E and K thermocouples. Tophel® is a registered trademark of Carpenter Technology.

transducer A device that receives energy in one form and retransmits it in another form. For example, a thermocouple transforms heat energy input into a voltage output.

transient A surge in electrical current, usually of short duration. Transients can damage or interfere with the proper operation of electronic temperature and power controllers.

transmitter A device that transmits temperature data from either a thermocouple or a resistance temperature detector (RTD) by way of a two-wire loop. The loop has an external power supply. The transmitter acts as a variable resistor with respect to its input signal. Transmitters are desirable when long lead or extension wires produce unacceptable signal degradation.

Transport Layer (OSI Layer 4) The fourth layer of the seven-layer OSI (Open System Interconnection) protocol model that handles data transfer, flow control and error recovery between communicating hosts. The Transport Layer resides between the Session Layer and the Network Layer.

triac A solid-state device that switches alternating current.

tribology The science or study of surface friction.

triple point A thermodynamic state in which the gas, liquid and solid phases all occur in equilibrium. For water, the triple point is 0.01°C at standard atmospheric pressure.

tungsten (W) An element that is used as the positive conductor in a Type G thermocouple, which is made of tungsten/tungsten 26 percent rhenium (W/W26Re). Type G is not an ASTM symbol.

tungsten 25 percent rhenium The thermocouple alloy that is used as the negative conductor in a Type D thermocouple, which is made of tungsten 3 percent rhenium/tungsten 25 percent rhenium thermocouple (W3Re/W25Re). Type D is not an ASTM symbol.

tungsten 26 percent rhenium The thermocouple alloy that is used as the negative conductor in both the Type G thermocouple, which is made of tungsten/tungsten 26 percent rhenium (W/W26Re), and the Type C thermocouple, which is made of tungsten 5 percent/tungsten 26 percent rhenium (W5Re/W26Re). Types G and C are not ASTM symbols.

tungsten 3 percent rhenium The thermocouple alloy that is used as the positive conductor in a Type D thermocouple, which is made of tungsten 3 percent rhenium/tungsten 25 percent rhenium (W3Re/W25Re). Type D is not an ASTM symbol.

Glossary

tungsten 5 percent rhenium The thermocouple alloy that is used as the positive conductor in a Type C thermocouple, which is made of tungsten percent rhenium/tungsten 26 percent rhenium (W5Re/W26Re). Type C is not an ASTM symbol.

tungsten lamp The technology used by the standard incandescent light bulb, in place since 1911, with a tungsten metal filament surrounded by an inert gas or a vacuum. Tungsten has a 16:1 hot to cold resistance ratio, that is, the filament has 16 time higher resistance at its hot operating temperature than at cooler ambient.

turnkey A selling feature describing a complete and ready to use system, one similar to simply turning the door key of a ready-to-live-in home. Watlow offers turnkey solutions with cast-in and thick film heaters.

twisted pair Two insulated conductors that are twisted together. An effective method of duplexing and reducing electromagnetic interference (EMI).

U

UDP User Datagram Protocol. A connectionless protocol that runs on top of IP networks as UDP/IP. Hosts can broadcast messages via UDP/IP without establishing connections with the receivers. Datagrams are packets, pieces of messages. UDP is a sessionless transport layer protocol defined by the IETF.

UL® The registered trademark and abbreviation for the Underwriter's Laboratories, Inc. An independent testing laboratory that establishes commercial and industrial standards, and tests and certifies products in the United States.

ultraviolet The portion of the electromagnetic spectrum that is just beyond the violet in the visible spectrum. Ultraviolet light can degrade many insulation materials.

undershoot The amount by which a process variable falls below the set point before it stabilizes.

ungrounded junction See "isolated junction."

uninsulated Without thermal insulation; without electrical insulation (bare wire).

union A pipe fitting that joins extension pipes, without regard to their thread orientation.

upscale break protection A form of break detection for burned-out thermocouples. It signals the operator that the thermocouple has burned out.

USB Universal Serial Bus. An external bus standard for connecting as many as 127 peripheral devices to computers with data transfer rates of up to 12 Mbps (million bits per second). USB is likely to supercede serial and parallel ports because of its speed and "hot swappable" (unplug and plug in with power on) feature.

V

vacuum braze A process to join metals or alloys with heat in the absence of atmosphere, in a vacuum chamber or furnace, for example.

value The quantitative measure of a signal or variable.

VDE Abbreviation for Verband Deutscher Elektrotechniker, an independent German testing and certification institute concerned with the safety of electrical products. Authorizes use of the VDE Mark.

viscosity The resistance of fluid to sheering forces (flow). High viscosity indicates a tendency for a fluid to flow or move slowly. The viscosity of fluids decreases as their temperatures increase. Heating gases will increase their absolute viscosity.

VOC 1) Volatile Organic Compound(s). Carbon-based organic compounds that evaporate quickly. Watlow's thick film heaters do not contain harmful volatile organic compounds, such as hydrocarbons, ammonia fluorine, hydrogen sulfide or sulfur dioxide. 2) Voice of the Customer; APICS (The Educational Society for Resource Management).

volt (V) The unit of measure for electrical potential, voltage or electromotive force (EMF). See "voltage."

volt amperes (VA) A measurement of apparent power. The product of voltage and current in a reactive circuit. $V I = VA$, where V is volts and I is current in amperes. The term watt is used for real power.

voltage (V) The difference in electrical potential between two points in a circuit. It's the push or pressure behind current flow through a circuit. One volt (V) is the difference in potential required to move one coulomb of charge between two points in a circuit, consuming one joule of energy. In other words, one volt (V) is equal to one ampere of current (I) flowing through one ohm of resistance (R), or $V = IR$.

Glossary

W - X

watt (W) A measurement of real power. The product of voltage and current in a resistive circuit. $VI = P$, where V is volts, I is current in amperes and P is power in watts.

watt density The watts of power produced per unit of surface area of a heater. Watt density indicates the potential for a surface to transmit heat energy and is expressed in W/in² or W/cm². This value is used to express heating element ratings and surface heat loss factors.

WCAD™ A computer-based version of a power calculations tool published by Watlow Polymer Technologies.

web server A device with an IP address and running server software to make it capable of serving web pages to a network or to the Internet. A web server may also have a domain name.

wire size The specification and use of proper wire gauge for the load size and its distance from the control. Wire sizing is of prime importance to output wiring. Refer to the National Electrical Code (NEC) and local codes for wire sizing guidelines. See “American Wire Gauge” and “B & S Gauge.”

working standard A measurement device that refers to a secondary standard.

WPT Watlow Polymer Technologies. A Watlow division that manufactures heated plastics.

XML eXtensible Markup Language. A document markup language defined by the Worldwide Web Consortium (WC3) as a subset of SGML (Standard Generalized Markup Language), and a web-friendly document description tool. XML provides for customized tags that enable data sharing between systems, applications and organizations.

Z

zero cross Action that provides output switching only at or near the zero-voltage crossing points of the AC sine wave. See “burst fire.”

zero switching See “zero cross.”

N O T E S

N O T E S